



---

INSTRUCTIONS FOR  
Extensa

---

# PROJECTA

A Milestone AV Technologies Brand

Franklinstraat 14  
6003 DK Weert - The Netherlands  
+31 495 580 840 / [emea.sales@milestone.com](mailto:emea.sales@milestone.com)  
[www.milestone.com](http://www.milestone.com)

**30751161**

## Included Hardware

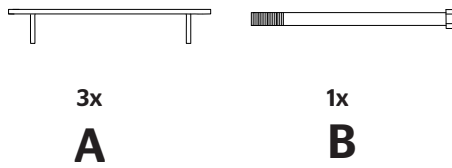

## Optional Hardware (on request)

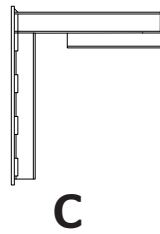

Product code: 10800159  
(3 brackets)

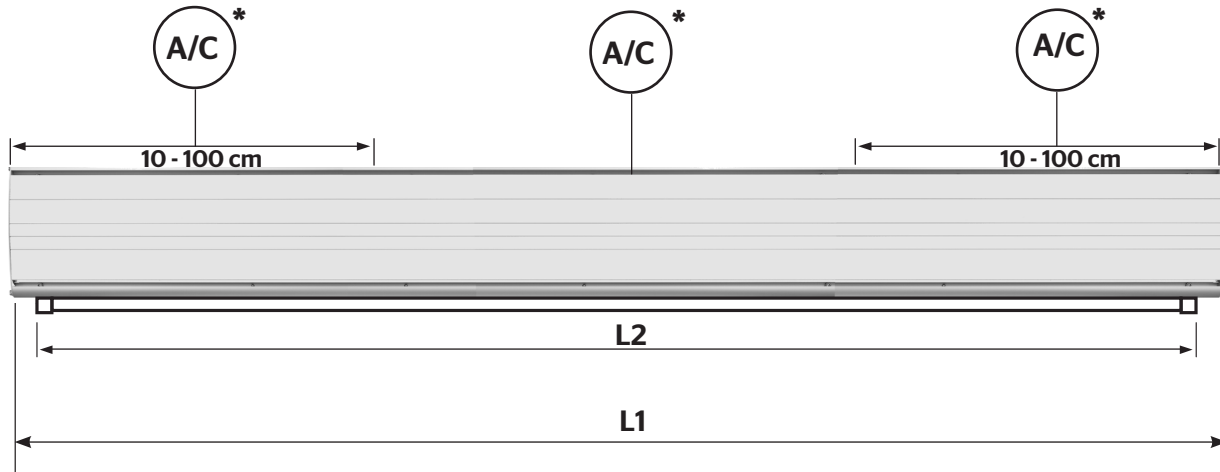

	Viewing Area (cm)	Extensa		
		L1 mm	L2 mm	Weight (kg)
16:10	244 x 390	4434	4086	103
	275 x 440	4958	4606	114
	306 x 490	5486	5131	125
	338 x 540	6016	5659	136
	369 x 590	6550	6190	147
16:9/ UHD	219 x 390	4434	4072	103
	248 x 440	4958	4588	114
	276 x 490	5486	5107	125
	304 x 540	6016	5629	136
	332 x 590	6550	6154	147
4K	206 x 390	4434	4072	103
	232 x 440	4958	4588	114
	258 x 490	5486	5107	125
	284 x 540	6016	5629	136
	311 x 590	6550	6154	147

### \* Bracket weight distribution

Please make sure the structure and mounting materials used are capable of carrying the weight of the screen. For safety please ensure each bracket can carry the full screen-weight. See chart for reference.



### Instructions for Use

Please see the 'instructions for Use' for detailed instructions for the wiring diagram and how to connect, operate and maintain this projection screen.

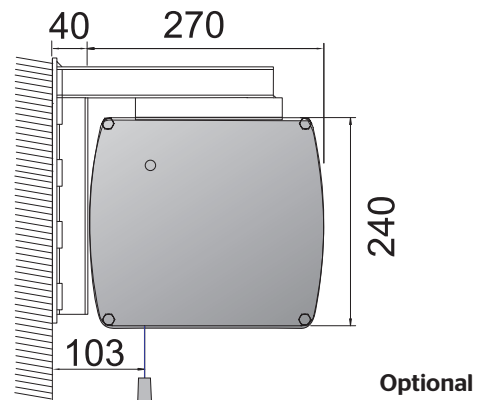
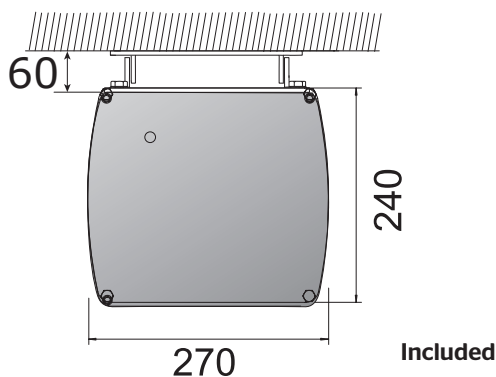

# Installation

## CEILING MOUNTED (included)

1. Define the position of the screen case on the ceiling. Position 2 ceiling brackets (A) within 10 to 100 cm of either end of the case and one approximately in the middle (case length /2 +/- 50 cm).

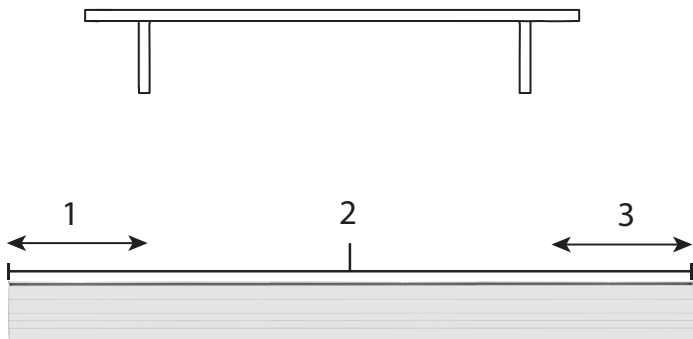

2. Move the sliding brackets on top of the case to match the exact positions of the 3 brackets on the ceiling.

3. Raise the screen case to the height of the ceiling brackets. Make sure the sliding brackets on top of the case align with the ceiling brackets.

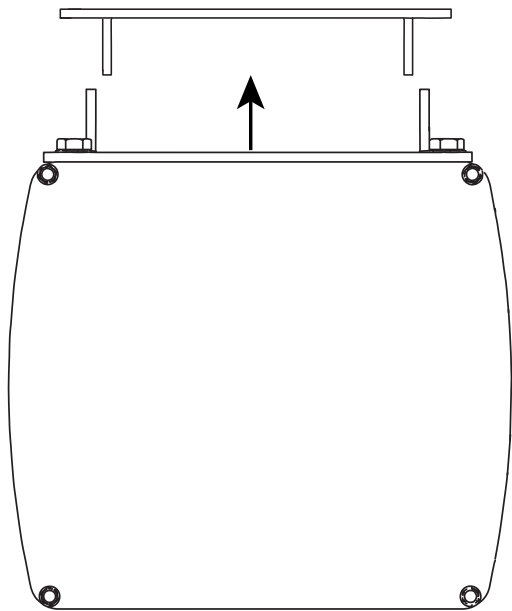

4. When the sliding bracket on the case and the ceiling bracket align, take the security bolt (B) and screw in place.

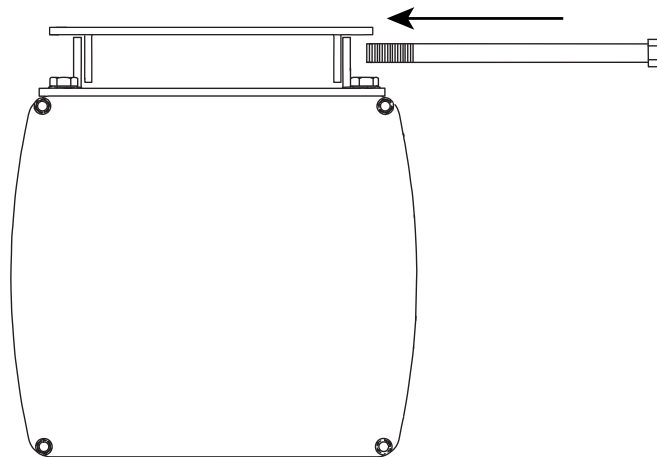

5. Tighten the security bolt on all 3 brackets until the case is fully secured.

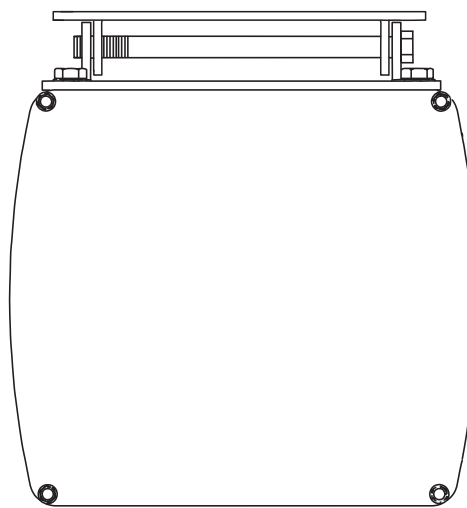

6. **Please note!** Remove transport-safety brackets from the slatbar before operating the screen.

## WALL MOUNTED (optional)

1. Define the position of the screen case on the wall. Position 2 wall brackets (C) within 10 to 100 cm of either end of the case and one approximately in the middle (case length  $/2 \pm 50$  cm).

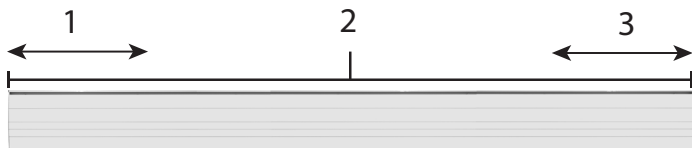
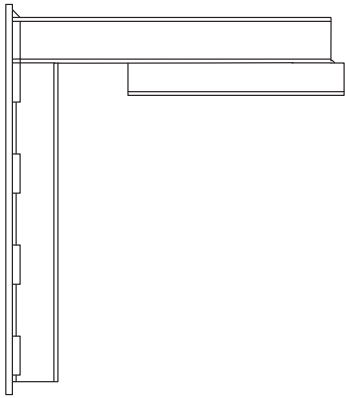

2. Move the sliding brackets on top of the case to match the exact positions of the 3 brackets on the wall.
3. Raise the screen case to the height of the wall brackets. Make sure the sliding brackets on top of the case align with the wall brackets.

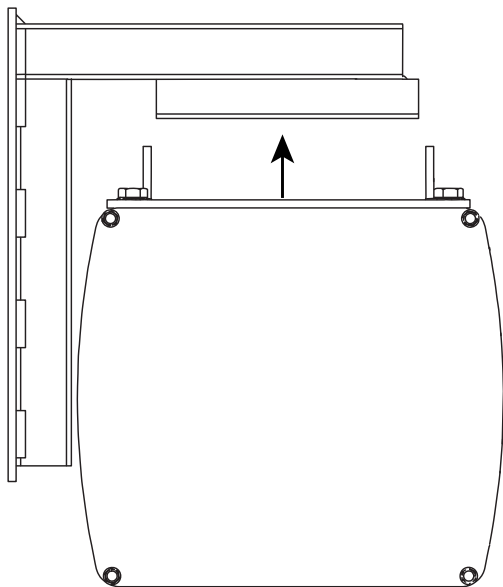

4. When the sliding bracket on the case and the wall bracket align, take the security bolt (C) and screw in place.

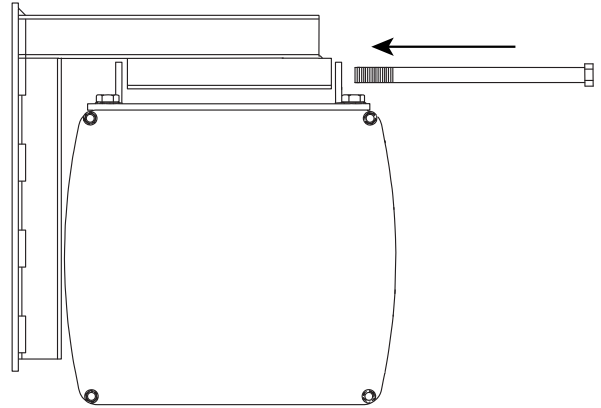

5. Tighten the security bolt on all 3 brackets until the case is fully secured.

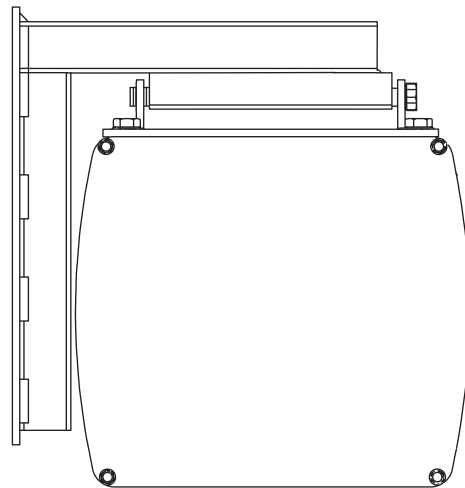

6. **Please note!** Remove transport-safety brackets from the slatbar before operating the screen.