

visual engineering  
**LIGHTWARE**

**User's Manual**



**HDMI-3D-OPT-TX210A**  
**HDMI-3D-OPT-TX210RAK**  
**SW4-OPT-TX240RAK**  
**HDMI-3D-OPT-RX150RA**

Fiber Optical Multimedia Extender

## Important Safety Instructions

### Class II apparatus construction.

The equipment should be operated only from the power source indicated on the product.

To disconnect the equipment safely from power, remove the power cord from the rear of the equipment, or from the power source. The MAINS plug is used as the disconnect device, the disconnect device shall remain readily operable.

There are no user-serviceable parts inside of the unit. Removal of the cover will expose dangerous voltages. To avoid personal injury, do not remove the cover. Do not operate the unit without the cover installed.

The appliance must be safely connected to multimedia systems. Follow instructions described in this manual.

### Ventilation

For the correct ventilation and to avoid overheating ensure enough free space around the appliance. Do not cover the appliance, let the ventilation holes free and never block or bypass the ventilators (if any).

### WARNING

To prevent injury, the apparatus is recommended to securely attach to the floor/wall or mount in accordance with the installation instructions. The apparatus shall not be exposed to dripping or splashing and that no objects filled with liquids, such as vases, shall be placed on the apparatus. No naked flame sources, such as lighted candles, should be placed on the apparatus.

## Waste Electrical & Electronic Equipment WEEE

This marking shown on the product or its literature, indicates that it should not be disposed with other household wastes at the end of its working life. To prevent possible harm to the environment or human health from uncontrolled waste disposal, please separate this from other types of wastes and recycle it responsibly to promote the sustainable reuse of material resources. Household users should contact either the retailer where they purchased this product, or their local government office, for details of where and how they can take this item for environmentally safe recycling. Business users should contact their supplier and check the terms and conditions of the purchase contract. This product should not be mixed with other commercial wastes for disposal.

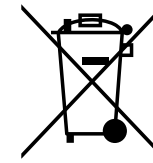

### Caution: Laser product

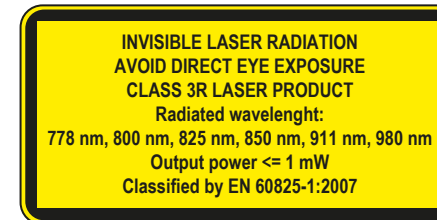
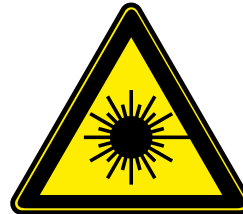

## Common Safety Symbols

Symbol	Description
	Direct current
	Alternating current
	Double insulation
	Caution, possibility of electric shock
	Caution
	Laser radiation

## Symbol Legend

The following symbols and markings are used in the document:

**WARNING!** Safety-related information which is highly recommended to read and keep in every case!

**ATTENTION!** Useful information to perform a successful procedure; it is recommended to read.

**INFO:** A notice which may contain additional information. Procedure can be successful without reading it.

**DEFINITION:** The short description of a feature or a function.

**TIPS AND TRICKS:** Ideas which you may have not known yet but can be useful.

## Navigation Buttons

 Go back to the previous page. If you clicked on a link previously, you can go back to the source page by clicking the button.

 Navigate to the Table of Contents.

 Step back one page.

 Step forward to the next page.

## Document Information

This User's Manual applies to the following versions of the mentioned software, firmware, and hardware:

Item	Version
Lightware Device Controller (LDC) software	1.18.0b6
Lightware Device Updater (LDU) software	1.5.0b8
Controller firmware - Transmitters	1.1.0
Controller firmware - Receiver	2.0.0
Hardware - Transmitters	1.1
Hardware - Receiver	1.3

Document revision: **2.1**

Release date: 31-10-2018

Editor: Laszlo Zsedenyi

## Table of Contents

<b>1. INTRODUCTION</b> .....	<b>7</b>	<b>3.8. VIDEO INTERFACE</b> .....	<b>18</b>	<b>5. SOFTWARE CONTROL - LIGHTWARE DEVICE CONTROLLER</b> ....	<b>27</b>
<b>1.1. DESCRIPTION</b> .....	7	<b>3.9. THE AUTOSELECT FEATURE</b> .....	18	<b>5.1. INSTALL AND UPGRADE</b> .....	27
<b>1.2. BOX CONTENTS</b> .....	7	<b>3.10. USB KVM FUNCTION</b> .....	19	<b>5.2. ESTABLISHING THE CONNECTION</b> .....	27
<b>1.3. COMPATIBLE DEVICES</b> .....	7	<b>3.11. CONTROLLING FEATURES</b> .....	20	<b>5.3. CROSSPOINT / PORT CONTROL MENU</b> .....	28
<b>1.4. FEATURES</b> .....	8	3.11.1. Serial Interface .....	20	<b>5.4. PORT PROPERTIES WINDOWS</b> .....	29
<b>1.5. MODEL COMPARISON OF THE TRANSMITTERS</b> .....	8	3.11.2. GPIO Interface .....	21	5.4.1. Video Inputs.....	29
<b>1.6. TYPICAL APPLICATION</b> .....	8	3.11.3. USB Control Interface.....	22	5.4.2. Digital Audio Inputs .....	29
<b>2. INSTALLATION</b> .....	<b>10</b>	3.11.4. Ethernet Control Interface .....	22	5.4.3. Analog Audio Inputs .....	30
<b>2.1. MOUNTING OPTIONS</b> .....	<b>10</b>	<b>3.12. FURTHER BUILT-IN FEATURES</b> .....	<b>22</b>	5.4.4. Video Outputs .....	30
2.1.1. 1U High Rack Shelf.....	10	3.12.1. Automatically Launched Actions - The Event Manager .....	22	5.4.5. Digital Audio Outputs .....	31
2.1.2. Under-desk Mounting Kit .....	10	3.12.2. Advanced EDID Management.....	22	5.4.6. Analog Audio Output .....	31
2.1.3. Under-desk Double Mounting Kit.....	10	<b>4. OPERATION</b> .....	<b>23</b>	<b>5.5. DIAGNOSTIC TOOLS</b> .....	<b>31</b>
<b>2.2. CONNECTING STEPS</b> .....	<b>11</b>	<b>4.1. FRONT PANEL LEDs - TRANSMITTER</b> .....	<b>23</b>	5.5.1. Frame Detector .....	31
2.2.1. Receiver.....	11	4.1.1. Video Input LEDs .....	23	5.5.2. No Sync Screen (Test Pattern) .....	32
2.2.2. Transmitter.....	11	4.1.2. Audio Input LEDs .....	23	<b>5.6. USB KVM</b> .....	<b>32</b>
<b>3. PRODUCT OVERVIEW</b> .....	<b>12</b>	4.1.3. HDCP LED .....	23	5.6.1. USB KVM in the Receiver .....	32
<b>3.1. FRONT VIEW - TRANSMITTER</b> .....	<b>12</b>	4.1.4. USB LED .....	23	5.6.2. USB KVM in the Transmitter .....	32
<b>3.2. REAR VIEW - TRANSMITTER</b> .....	<b>13</b>	4.1.5. Autoselect LED .....	23	<b>5.7. EDID MENU</b> .....	<b>33</b>
<b>3.3. FRONT AND REAR VIEW - RECEIVER</b> .....	<b>13</b>	<b>4.2. FRONT PANEL BUTTONS - TRANSMITTER</b> .....	<b>23</b>	5.7.1. EDID Operations.....	33
<b>3.4. ELECTRICAL CONNECTIONS</b> .....	<b>13</b>	4.2.1. Video Select Button.....	23	5.7.2. EDID Summary Window .....	34
3.4.1. 5V DC Connection .....	13	4.2.2. Audio Select Button.....	24	5.7.3. Editing an EDID .....	34
3.4.2. HDMI Connector .....	14	4.2.3. Programmable Show Me Button .....	24	5.7.4. Creating an EDID - Easy EDID Creator .....	35
3.4.3. DVI-I Connector.....	14	<b>4.3. SPECIAL FUNCTIONS - TRANSMITTER</b> .....	<b>24</b>	<b>5.8. CONTROL / DEVICE CONTROL MENU</b> .....	<b>35</b>
3.4.4. DisplayPort Connector .....	14	4.3.1. Enable DHCP (Dynamic) IP Address .....	24	5.8.1. RS-232 .....	35
3.4.5. SC Fiber Optical Connector.....	14	4.3.2. Reset to Factory Default Settings.....	24	5.8.2. GPIO .....	36
3.4.6. Analog Stereo Audio Connector (3.5 mm Jack).....	14	4.3.3. Control Lock.....	24	5.8.3. Ethernet.....	36
3.4.7. Analog Stereo Audio Connector (5-pole Phoenix).....	14	4.3.4. Resetting the Device.....	24	<b>5.9. EVENT MANAGER</b> .....	<b>37</b>
3.4.8. S/PDIF Connector.....	14	4.3.5. Entering Firmware Upgrade Mode.....	24	5.9.1. Create or Modify an Event.....	38
3.4.9. RS-232 Connector (3-pole Phoenix).....	14	<b>4.4. REAR PANEL STATUS LEDs - TRANSMITTER</b> .....	<b>24</b>	5.9.2. Special Tools and Accessories.....	38
3.4.10. RS-232 Connector (D-sub) .....	14	4.4.1. LIVE LED.....	24	5.9.3. Clear One or More Event(s).....	39
3.4.11. Ethernet Connector .....	15	4.4.2. LASER ACTIVE LED .....	24	5.9.4. Export and Import Events .....	39
3.4.12. USB Mini Connector .....	15	4.4.3. FIBER LINK LED .....	25	5.9.5. Event Creating - Example .....	39
3.4.13. USB Connector for KVM.....	15	4.4.4. RS-232 LED .....	25	<b>5.10. SETTINGS MENU</b> .....	<b>40</b>
3.4.14. GPIO - General Purpose Input/Output Ports.....	15	<b>4.5. FRONT PANEL LEDs - RECEIVER</b> .....	<b>25</b>	5.10.1. Status .....	40
<b>3.5. OPTICAL EXTENDER CONCEPT</b> .....	<b>15</b>	4.5.1. POWER LED.....	25	5.10.2. Network.....	40
3.5.1. Transmitter.....	15	4.5.2. Status LEDs.....	25	5.10.3. Backup .....	40
3.5.2. Receiver.....	16	<b>4.6. SPECIAL FUNCTIONS - RECEIVER</b> .....	<b>25</b>	5.10.4. System .....	41
<b>3.6. PORT DIAGRAMS</b> .....	<b>16</b>	4.6.1. Reset to Factory Default Settings.....	25	<b>5.11. CONFIGURATION CLONING (BACKUP TAB)</b> .....	<b>41</b>
<b>3.7. AUDIO INTERFACE</b> .....	<b>17</b>	4.6.2. Entering Firmware Upgrade Mode.....	25	5.11.1. Steps in a Nutshell .....	41
3.7.1. Audio Inputs and Modes - Transmitter.....	17	<b>4.7. SOFTWARE CONTROL MODES</b> .....	<b>26</b>	5.11.2. Save the Settings of a Device (Backup).....	42
3.7.2. Audio Outputs and Modes - Receiver.....	17			5.11.3. Upload the Settings to a Device (Restore).....	42
3.7.3. Audio Options - Example.....	18			<b>5.12. ADVANCED VIEW WINDOW</b> .....	<b>42</b>

## Table of Contents

<b>6. LW2 PROGRAMMER'S REFERENCE</b> .....	<b>43</b>	<b>7.3. LW3 COMMANDS</b> .....	<b>53</b>	7.7.6. Change the Autoselect Mode .....	64
<b>6.1. LW2 PROTOCOL DESCRIPTION</b> .....	<b>43</b>	7.3.1. Get Command.....	53	7.7.7. Query the Input Port Priority .....	65
<b>6.2. GENERAL LW2 COMMANDS</b> .....	<b>43</b>	7.3.2. Set Command .....	54	7.7.8. Change the Input Port Priority .....	65
6.2.1. View Product Type.....	43	7.3.3. Invocation .....	54	7.7.9. Mute an Audio Input.....	65
6.2.2. Query Control Protocol.....	43	7.3.4. Manual .....	55	7.7.10. Unmute an Audio Input .....	65
6.2.3. View Firmware Version of the CPU .....	44	7.3.5. Signature .....	55	7.7.11. Lock an Input Port .....	65
6.2.4. Connection Test.....	44	7.3.6. Subscription.....	55	7.7.12. Unlock an Input Port.....	65
6.2.5. View Serial Number .....	44	7.3.7. Notifications about the Changes of the Properties .....	56	7.7.13. Mute Audio Output .....	65
6.2.6. Compile Time.....	44	<b>7.4. FORMAL DEFINITIONS</b> .....	<b>56</b>	7.7.14. Unmute Audio Output.....	66
6.2.7. View Installed Board.....	44	<b>7.5. SYSTEM COMMANDS</b> .....	<b>57</b>	7.7.15. Lock Output .....	66
6.2.8. View Firmware for All Controllers.....	44	7.5.1. Query the Product Name.....	57	7.7.16. Unlock Output .....	66
6.2.9. Restart the Device .....	44	7.5.2. Set the Device Label.....	57	7.7.17. Analog Audio Input Level Settings .....	66
6.2.10. Query Health Status .....	44	7.5.3. Query the Serial Number .....	57	7.7.18. Analog Audio Input Level Settings by Steps.....	67
6.2.11. Restore Factory Default Settings.....	44	7.5.4. Query the Firmware Version .....	57	7.7.19. Analog Audio Output Level Settings .....	67
<b>6.3. A/V PORT SETTINGS</b> .....	<b>45</b>	7.5.5. Resetting the Device.....	57	7.7.20. Analog Audio Output Level Settings by Steps .....	68
6.3.1. Switch an Input to the Outputs .....	45	7.5.6. Restore the Factory Default Settings .....	57	<b>7.8. NETWORK CONFIGURATION</b> .....	<b>68</b>
6.3.2. Mute Output .....	45	<b>7.6. VIDEO PORT SETTINGS</b> .....	<b>58</b>	7.8.1. Query the DHCP State .....	68
6.3.3. Unmute Output .....	45	7.6.1. Query the Status of Source Ports .....	58	7.8.2. Change the DHCP State .....	68
6.3.4. Lock Output.....	45	7.6.2. Query the Status of Destination Port .....	59	7.8.3. Query the IP Address.....	68
6.3.5. Unlock Output .....	45	7.6.3. Query the Video Crosspoint Setting .....	59	7.8.4. Change the IP Address (Static) .....	68
6.3.6. View Connection State on the Output .....	46	7.6.4. Switching Video Input .....	59	7.8.5. Query the Subnet Mask.....	68
6.3.7. View Crosspoint Size.....	46	7.6.5. Query the Video Autoselect Settings.....	59	7.8.6. Change the Subnet Mask (Static).....	68
6.3.8. Change Video Autoselect Mode .....	46	7.6.6. Change the Autoselect Mode .....	59	7.8.7. Query the Gateway Address .....	69
6.3.9. Change Audio Autoselect Mode.....	46	7.6.7. Query the Input Port Priority .....	60	7.8.8. Change the Gateway Address (Static) .....	69
6.3.10. Change the Video Input Priorities.....	47	7.6.8. Change the Input Port Priority .....	60	7.8.9. Apply Network Settings.....	69
6.3.11. Change the Audio Input Priorities .....	47	7.6.9. Mute an Input Port.....	60	<b>7.9. RS-232 PORT CONFIGURATION</b> .....	<b>69</b>
<b>6.4. NETWORK CONFIGURATION</b> .....	<b>47</b>	7.6.10. Unmute an Input Port.....	60	7.9.1. Protocol Setting.....	69
6.4.1. Query the Current IP Status .....	47	7.6.11. Lock an Input Port .....	60	7.9.2. BAUD Rate Setting.....	69
6.4.2. Set the IP Address .....	47	7.6.12. Unlock an Input Port.....	60	7.9.3. Databit Setting.....	69
6.4.3. Set the Subnet Mask .....	47	7.6.13. Mute Output .....	60	7.9.4. Stopbits Setting .....	69
6.4.4. Set the Gateway Address.....	48	7.6.14. Unmute Output .....	61	7.9.5. Parity Setting.....	70
6.4.5. Apply Network Settings.....	48	7.6.15. Lock Output .....	61	7.9.6. RS-232 Operation Mode .....	70
<b>6.5. GPIO CONFIGURATION</b> .....	<b>48</b>	7.6.16. Unlock Output .....	61	<b>7.10. SENDING MESSAGE VIA THE COMMUNICATION PORTS</b> .....	<b>70</b>
6.5.1. Set Level and Direction for Each Pins .....	48	7.6.17. HDCP Setting (Input Port).....	61	7.10.1. Sending Message via TCP Port .....	70
<b>6.6. LW2 COMMANDS – QUICK SUMMARY</b> .....	<b>49</b>	7.6.18. HDCP Setting (Output Port).....	61	7.10.2. Sending Message via UDP Port.....	71
<b>7. LW3 PROGRAMMER'S REFERENCE</b> .....	<b>50</b>	7.6.19. Test Pattern Generator.....	61	7.10.3. Sending Message via an RS-232 Port.....	71
<b>7.1. OVERVIEW</b> .....	<b>50</b>	7.6.20. HDMI Mode Settings (Output Port).....	62	<b>7.11. GPIO PORT CONFIGURATION</b> .....	<b>72</b>
7.1.1. Elements of the Tree Structure .....	50	<b>7.7. AUDIO PORT SETTINGS</b> .....	<b>63</b>	7.11.1. Set the Direction of a GPIO Pin.....	72
7.1.2. Escaping.....	52	7.7.1. Query the Status of Source Ports .....	63	7.11.2. Set the Output Level of a GPIO Pin.....	72
7.1.3. Error Messages.....	52	7.7.2. Query the Status of Destination Port .....	63	7.11.3. Toggle the Level of a GPIO Pin .....	72
7.1.4. Prefix Summary .....	52	7.7.3. Query the Audio Crosspoint Setting .....	64	<b>7.12. EDID MANAGEMENT</b> .....	<b>72</b>
<b>7.2. THE TREE STRUCTURE OF THE TRANSMITTER</b> .....	<b>52</b>	7.7.4. Switching Audio Input .....	64	7.12.1. Query the Emulated EDIDs.....	72
		7.7.5. Query the Audio Autoselect Settings .....	64	7.12.2. Query the Validity of a Dynamic EDID .....	72

## Table of Contents

7.12.3. Query the Preferred Resolution of an User EDID .....	72	<b>11.8. FACTORY EDID LIST .....</b>	<b>96</b>
7.12.4. Emulating an EDID to an Input Port.....	72	<b>11.9. FURTHER INFORMATION.....</b>	<b>97</b>
7.12.5. Emulating an EDID to All Input Ports.....	73		
7.12.6. Copy an EDID to User Memory .....	73		
7.12.7. Deleting an EDID from User Memory .....	73		
7.12.8. Resetting the Emulated EDIDs.....	73		
<b>7.13. LW3 COMMANDS - QUICK SUMMARY .....</b>	<b>74</b>		
<b>8. FIRMWARE UPGRADE .....</b>	<b>77</b>		
<b>8.1. ABOUT THE FIRMWARE PACKAGE (LFP FILE).....</b>	<b>77</b>		
<b>8.2. SHORT INSTRUCTIONS.....</b>	<b>77</b>		
<b>8.3. INSTALL AND UPGRADE .....</b>	<b>77</b>		
<b>8.4. DETAILED INSTRUCTIONS.....</b>	<b>78</b>		
8.4.1. Establish the Connection .....	78		
8.4.2. Prepare the Firmware Upgrade in LDC.....	78		
8.4.3. Start the LDU and Follow the Instructions .....	78		
<b>8.5. KEEPING THE CONFIGURATION SETTINGS .....</b>	<b>82</b>		
<b>9. TROUBLESHOOTING .....</b>	<b>83</b>		
<b>9.1. USE CASE STUDIES .....</b>	<b>83</b>		
<b>9.2. HOW TO SPEED UP THE TROUBLESHOOTING PROCESS .....</b>	<b>85</b>		
<b>10. TECHNOLOGIES.....</b>	<b>86</b>		
<b>10.1. EDID MANAGEMENT.....</b>	<b>86</b>		
10.1.1. Understanding the EDID.....	86		
10.1.2. Advanced EDID Management.....	86		
<b>10.2. HDCP MANAGEMENT .....</b>	<b>87</b>		
10.2.1. Protected and Unprotected Content .....	87		
10.2.2. Disable Unnecessary Encryption.....	87		
<b>10.3. PIXEL ACCURATE RECLOCKING .....</b>	<b>88</b>		
<b>11. APPENDIX .....</b>	<b>89</b>		
<b>11.1. SPECIFICATION .....</b>	<b>89</b>		
11.1.1. HDMI-3D-OPT-TX200 series Transmitters .....	89		
11.1.2. HDMI-3D-OPT-RX150RA Receiver .....	90		
<b>11.2. INPUT/OUTPUT PORT NUMBERING.....</b>	<b>91</b>		
<b>11.3. FACTORY DEFAULT SETTINGS.....</b>	<b>92</b>		
11.3.1. Transmitter .....	92		
11.3.2. Receiver.....	92		
<b>11.4. CONTENT OF BACKUP FILE.....</b>	<b>93</b>		
<b>11.5. MAXIMUM FIBER CABLE EXTENSIONS.....</b>	<b>93</b>		
<b>11.6. MECHANICAL DRAWINGS .....</b>	<b>94</b>		
11.6.1. Transmitter .....	94		
11.6.2. Receiver.....	94		
<b>11.7. AUDIO CABLE WIRING GUIDE .....</b>	<b>95</b>		

# 1

## Introduction

Thank You for choosing Lightware's HDMI-3D-OPT series device. In the first chapter we would like to introduce the device highlighting the most important features in the below listed sections:

- ▶ [DESCRIPTION](#)
- ▶ [BOX CONTENTS](#)
- ▶ [COMPATIBLE DEVICES](#)
- ▶ [FEATURES](#)
- ▶ [MODEL COMPARISON OF THE TRANSMITTERS](#)
- ▶ [TYPICAL APPLICATION](#)

### 1.1. Description

HDMI-3D-OPT series transmitters and receivers extend HDMI 1.4, DVI 1.0, HDCP and bi-directional RS-232 signals over one multi-mode fiber and transmit video signal with embedded audio to a distance of up to 2500 meters.

The extender was designed to handle HDMI 1.4 and DP 1.1 digital video signals and analog stereo audio from local inputs or HDMI embedded audio up to eight-channel PCM or HBR audio. Analog audio is converted into digital format. The device has a local HDMI video output for monitoring. The video and the embedded audio of the local output is the same as the one transmitted via the OPT link. The HDMI-3D-OPT series extenders handles HDCP encryption.

Using the factory, custom or transparent EDID emulation the user can fix and lock EDID data on each input connector. Advanced EDID Management forces the required resolution from any video source and fixes the output format conforming to the system requirements. The unit offers bi-directional and transparent RS-232.

All devices can be mounted on a rack shelf or used standalone. HDMI-3D-OPT series extenders are compatible with both OPT series extenders and matrix switchers.

The device features Pixel Accurate Reclocking, a Lightware technology to eliminate jitter and skew generated by low quality sources and multiple daisy-chained devices.

Single fiber technology makes these units fully HDMI and HDCP compliant without a need of a second fiber cable or copper connections. The bi-directional communication required for HDCP handshaking is performed via the same fiber core that transmits the video signal.

Galvanic isolation between source and display helps avoiding ground loops and hum effects. No delay occurs in the signal during optical conversion, the video image is transported without frame latency. This feature is crucial in 3D applications and systems where audio is processed separately.

#### Model Denomination

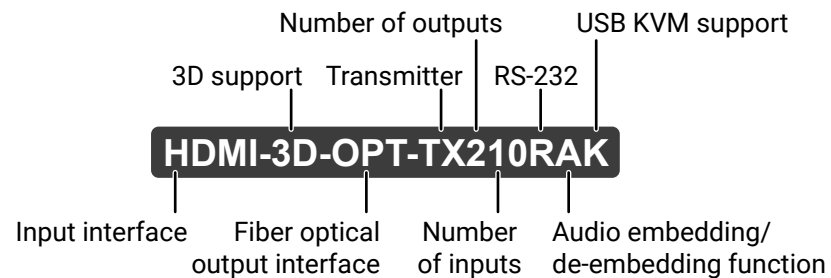

### 1.2. Box Contents

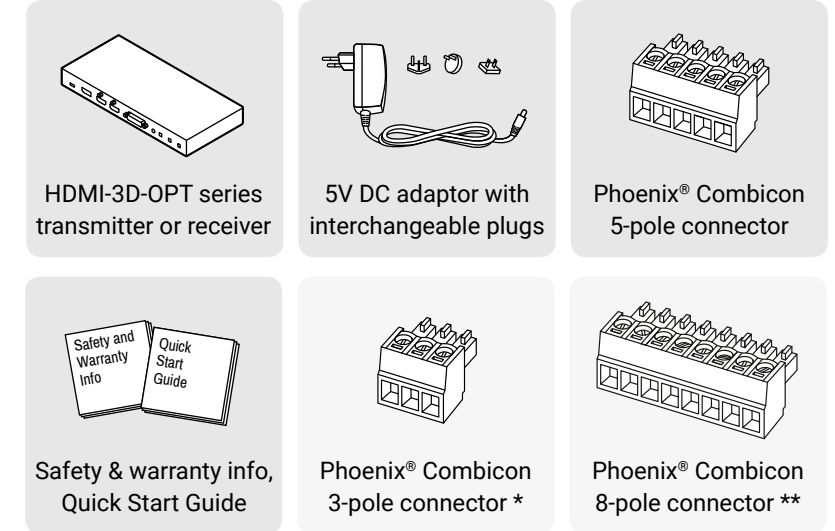

\* Only for HDMI-3D-OPT series transmitters.

\*\* Only for SW4-OPT-TX240RAK model.

### 1.3. Compatible Devices

#### Transmitter

The transmitters are compatible with the following receivers and input boards:

- HDMI-3D-OPT-RX150RA receiver;
- MX modular frames with MX-DVI-OPT-IB and MX-HDMI-OPT-IB cards.

#### Receiver

The receiver is compatible with the following transmitters and output boards:

- HDMI-3D-OPT series transmitters;
- UMX-OPT-TX150R transmitter;
- HDMI-OPT series transmitters;
- MX modular frames with MX-DVI-OPT-OB and MX-HDMI-OPT-OB cards.

### 1.4. Features



#### 3D and 4K Support

High bandwidth allows extension of resolutions up to 4K and even 3D sources and displays are supported.



#### Signal Transmission up to 2500 m

Video and audio signal transmission (DVI, HDMI or DisplayPort, and RS-232) over one multi-mode fiber optical cable.



#### Deep Color Support and Conversion

It is possible to transmit the highest quality 36-bit video streams for perfect color reproduction.



#### Autoselect Function for Video Inputs

The Autoselect feature can sense the port status on the video input ports and select automatically one of them. Priority number can be set for each input port and the feature allows to set various modes for the automatic input selection (First detect, Last detect, Priority mode).



#### HDCP-compliant

The receiver fulfills the HDCP standard. HDCP capability on the digital video inputs can be disabled when non-protected content is extended.



#### Built-in Event Manager

The Event Manager tool takes care of all the necessary control in a smaller configuration by performing predefined actions in response to device status changes. Hence, in a less complex environment, there is no need to invest in additional control solutions, which makes the receiver the best choice for numerous applications.



#### Pixel Accurate Reclocking

Each output has a clean, jitter free signal, eliminating signal instability and distortion caused by long cables or connector reflections.



#### USB KVM

Connected USB HID devices (e.g. keyboard, mouse, USB HUB) are extended from transmitter to receiver thus a computer can be remote controlled.



#### Bi-directional RS-232 Pass-through

AV systems can also contain serial port controllers and controlled devices. Serial port pass-through supports any unit that works with standard RS-232.



#### GPIO Control Port

7 GPIO pins operating at TTL digital signal levels and can be controlled with both LW2 and LW3 commands.

### 1.5. Model Comparison of the Transmitters

The available models have different features depending on their design. The following table contains the most important differences between the models:

	Ports									Optical output	
	Video ports				Audio ports		Interface ports				
	HDMI input	DVI-D input	DP input	HDMI output	Jack 3.5 input	Phoenix input	RS-232	Ethernet	GPIO	Serial comm.	USB KVM
<b>HDMI-3D-OPT-TX210A</b>	✓	-	-	✓	✓	✓	✓	-	-	C	-
<b>HDMI-3D-OPT-TX210RAK</b>	✓	-	-	✓	✓	✓	✓	-	-	C PT	✓
<b>SW4-OPT-TX240RAK</b>	✓	✓	✓	✓	✓	✓	✓	✓	✓	C PT CI	✓

C = Control mode, PT = Pass-through mode, CI = Command injection mode. See more information about serial interface modes in the [Serial Interface](#) section.

### 1.6. Typical Application

Application Diagram - HDMI-3D-OPT-TX210A

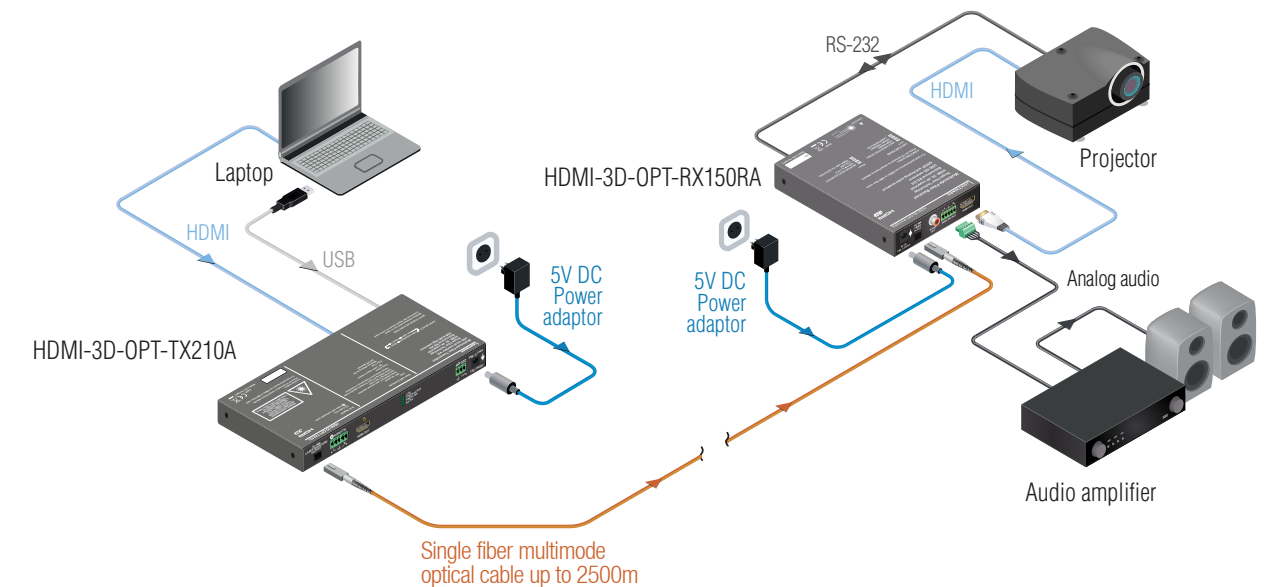



Application Diagram - HDMI-3D-OPT-TX210RAK

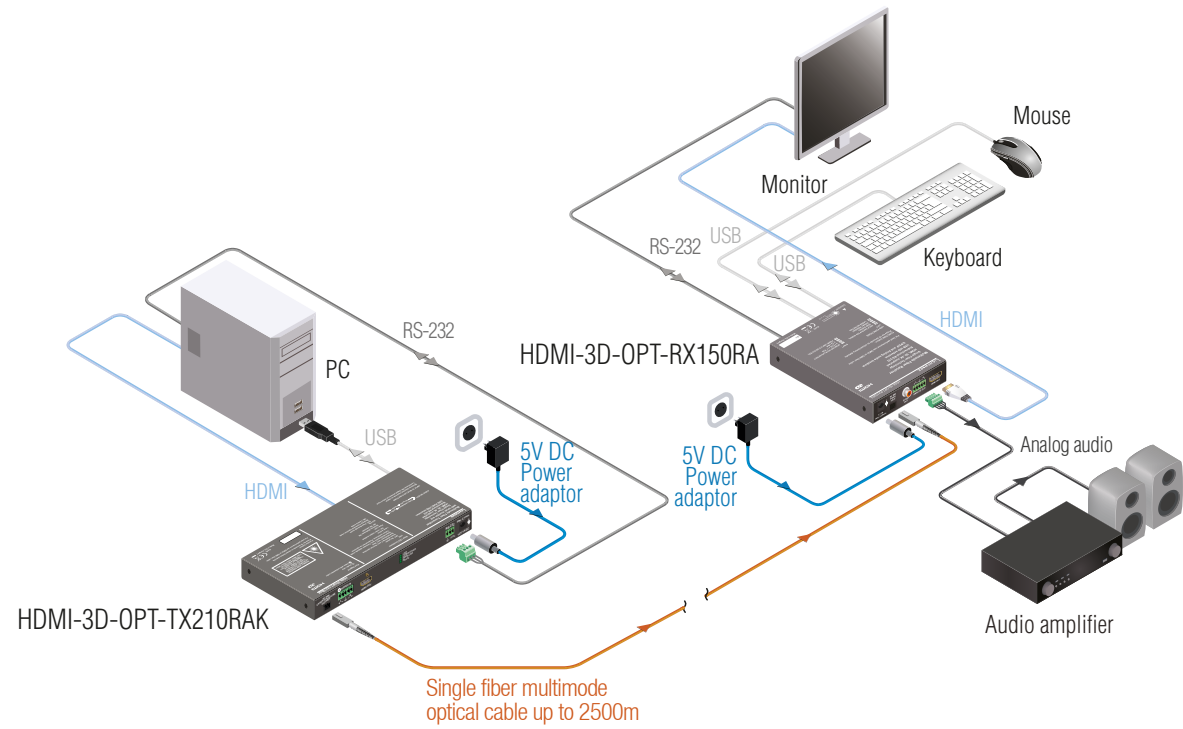

Application Diagram - SW4-OPT-TX240RAK

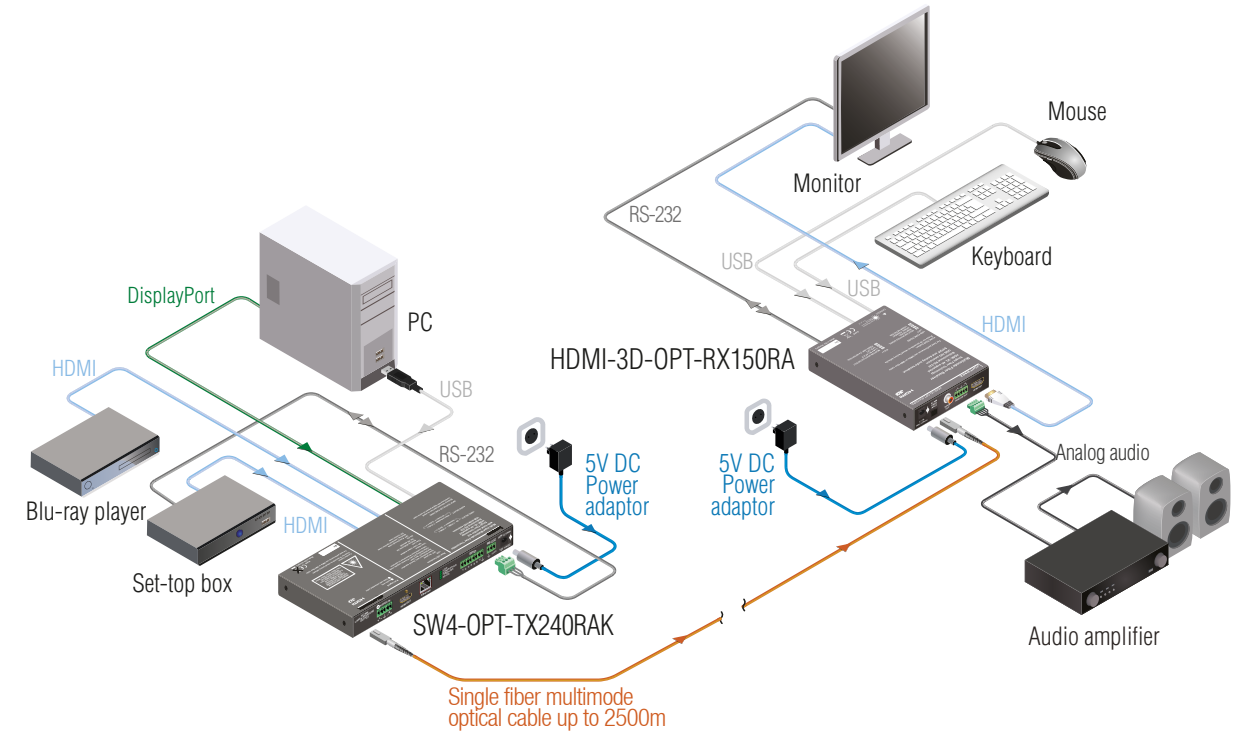

Integrated System Diagram - SW4-OPT-TX240RAK

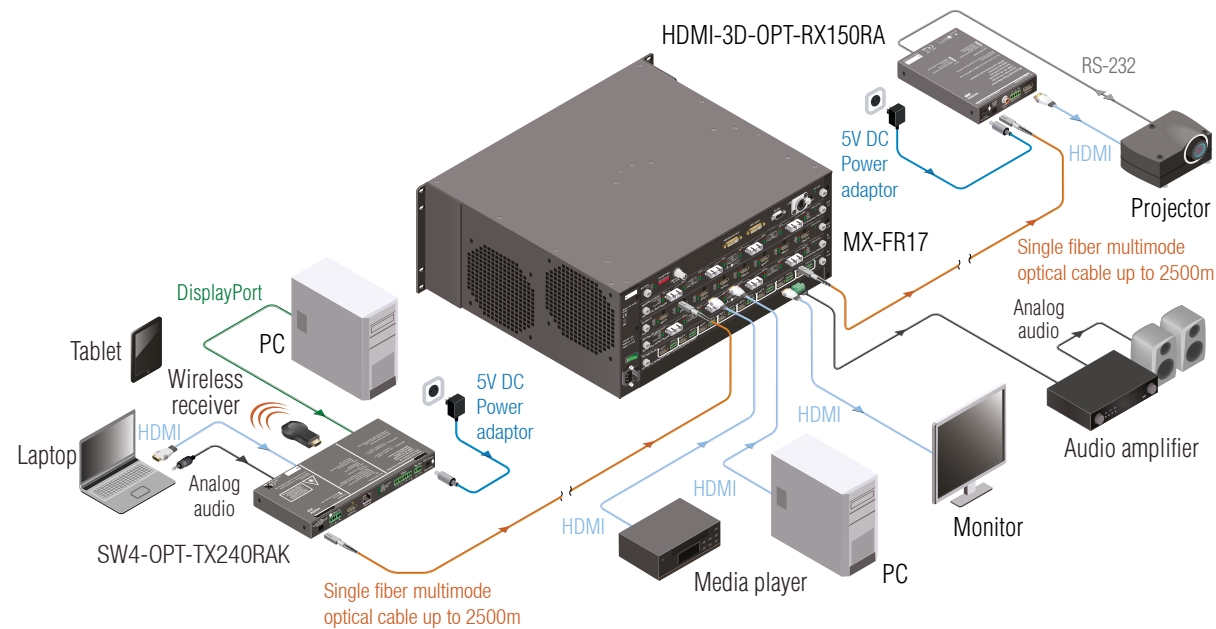

# 2

## Installation

The chapter is about the installation of the device and connecting to other appliances, presenting also the mounting options and further assembly steps:

- ▶ MOUNTING OPTIONS
- ▶ CONNECTING STEPS

### 2.1. Mounting Options

To mount the transmitter Lightware supplies optional accessories for different usage. There are two kinds of mounting kits with similar fixing method. The device has two mounting holes with inner thread on the bottom side; see the bottom view in the [Mechanical Drawings](#) section. Fasten the device by the screws enclosed to the accessory:

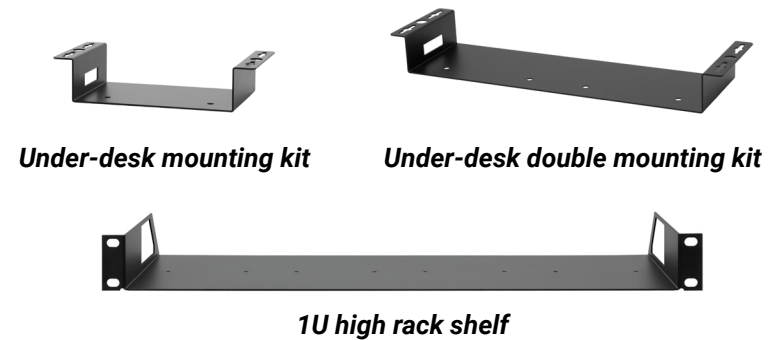

The Under-desk double mounting kit makes easy to mount a single device on any flat surface, e.g. furniture. 1U high rack shelf provides mounting holes for fastening two half-rack or four quarter-rack sized units. Pocket-sized devices can also be fastened on the shelf. To order mounting accessories please contact [sales@lightware.com](mailto:sales@lightware.com).

**WARNING! Always use the supplied screws. Using different (e.g. longer) ones may cause damage to the device.**

INFO: The transmitters are half-rack sized, the receiver is quarter-rack sized..

#### 2.1.1. 1U High Rack Shelf

Allows rack mounting for half-rack, quarter-rack and pocket sized units.

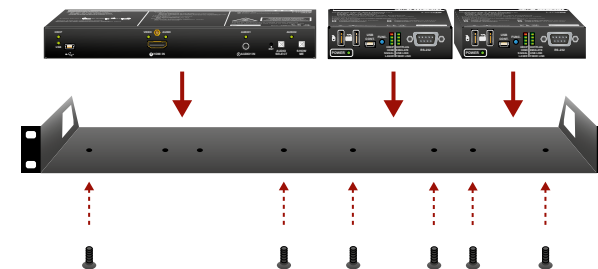

1U high rack shelf provides mounting holes for fastening two half-rack or four quarter-rack sized units. Pocket sized devices can also be fastened on the self.

#### 2.1.2. Under-desk Mounting Kit

The UD kit allows a receiver to be easily mounted on any flat surface (e.g. furniture). Only quarter-rack sized units (HDMI-3D-OPT-RX150RA receiver) can be installed to the kit.

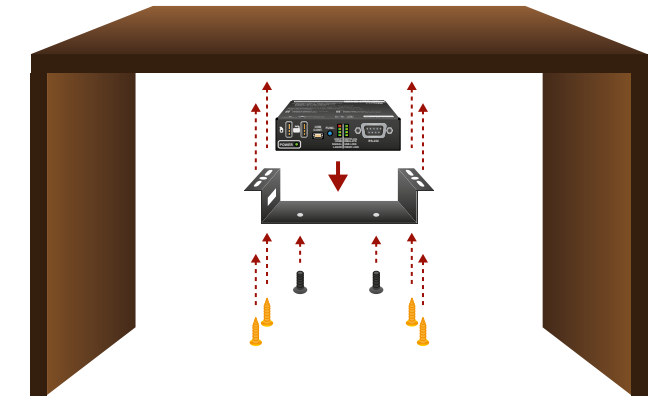

INFO: The chipboard screws are not supplied with the mounting kit.

#### 2.1.3. Under-desk Double Mounting Kit

The UD-kit double makes it easy to mount a single transmitter or multiple receivers on any flat surface (e.g. furniture).

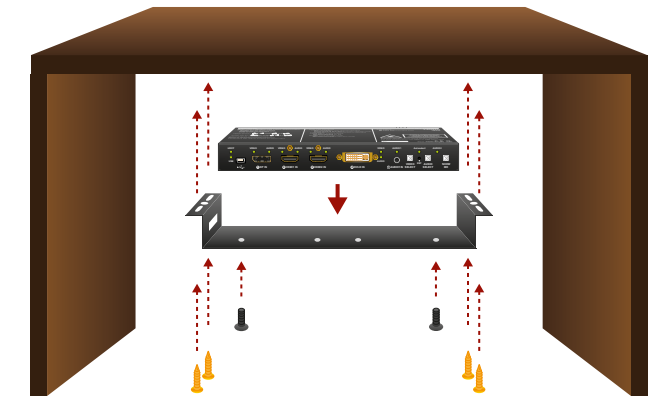

INFO: The chipboard screws are not supplied with the mounting kit.

## 2.2. Connecting Steps

### 2.2.1. Receiver

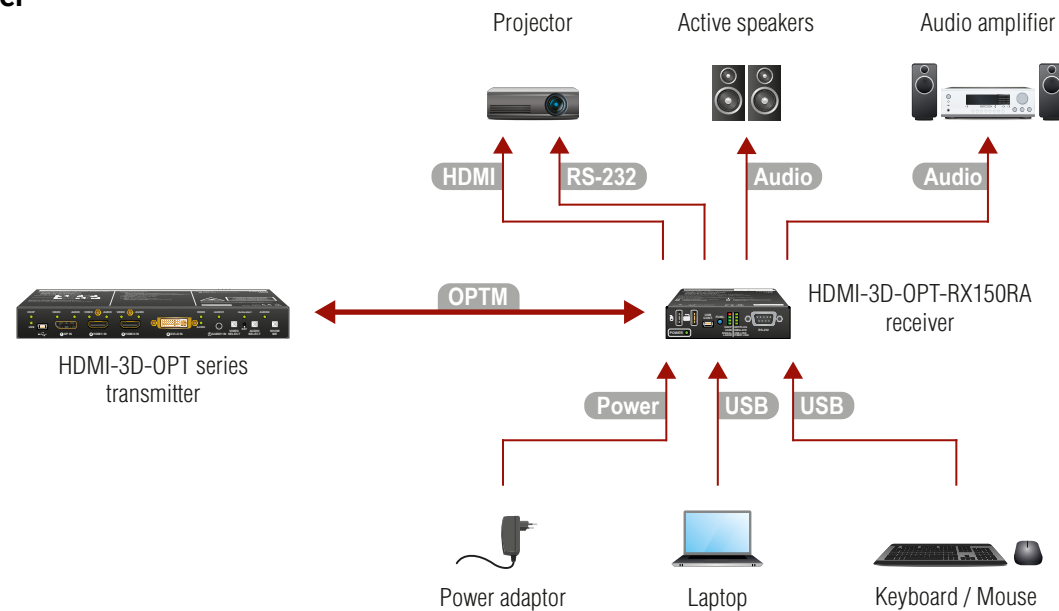

- OPTM** Connect the receiver and the compatible transmitter (e.g. a HDMI-3D-OPT series transmitter) or matrix output board using a multimode single fiber optical cable.
- HDMI** Connect the sink device (e.g. a projector) to the HDMI output port by an HDMI cable.
- RS-232** Optionally for RS-232 control: connect a controller/controlled device (e.g. projector) to the RS-232 port.
- Audio** Optionally connect an analog audio device with balanced audio signal (e.g. active speakers) to the 5-pole Phoenix audio output port. See the [Audio Cable Wiring Guide](#) for the correct wiring.
- Audio** Optionally connect a digital audio device (e.g. an audio amplifier) to the S/PDIF audio output port.
- USB** Optionally for USB control: connect the receiver to the controller device (e.g. laptop) by a USB mini B-type cable.
- USB** Optionally for USB HID extension: connect at least one USB HID device (e.g. keyboard and/or mouse) to the receiver.
- Power** Connect the power adaptor to the DC input of the receiver first, then to the AC power socket.

**ATTENTION:** Only HID-compliant devices are supported by the extenders. Non-HID devices (USB sticks, webcams, etc) will not be working with the receiver.

### 2.2.2. Transmitter

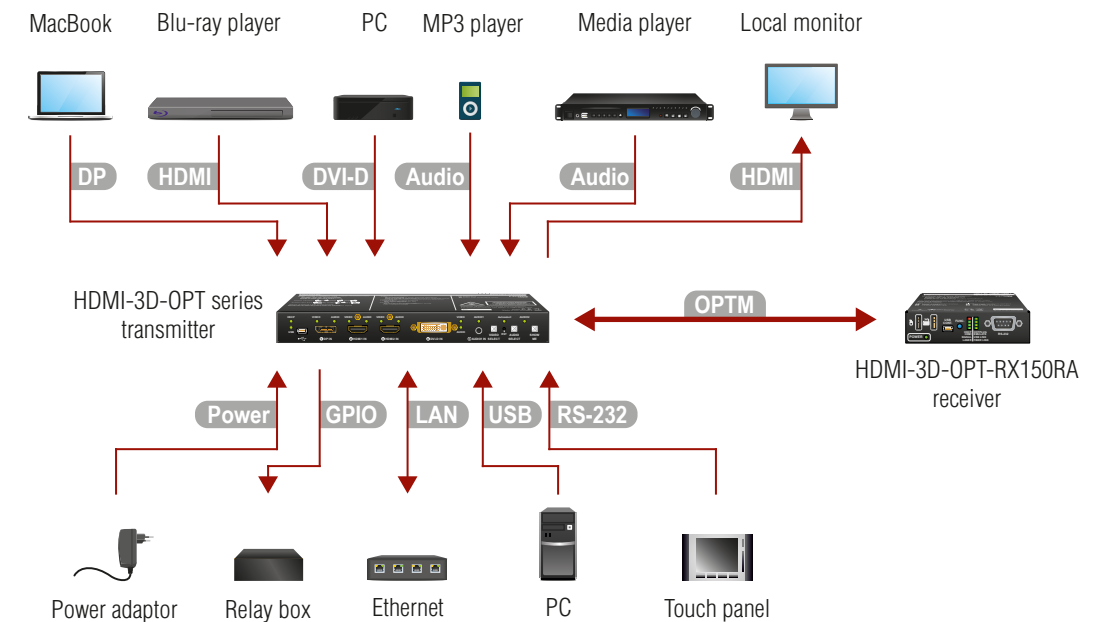

- OPTM** Connect the transmitter and the compatible receiver (e.g. a HDMI-3D-OPT-RX150RA) or matrix input board using a multimode single fiber optical cable.
- DP**  
**HDMI**  
**DVI-D** Connect the source(s) (e.g. a MacBook / Blu-ray player / PC) to the input port(s) of the transmitter by a DP / DVI-D / HDMI cable(s).
- Audio** Optionally connect an asymmetric audio device with unbalanced audio signal (e.g. an MP3 player) to the 2.5" TRS (jack) audio input port.
- Audio** Optionally connect a symmetric audio device with balanced audio signal (e.g. a media player) to the 5-pole Phoenix audio input port. See the [Audio Cable Wiring Guide](#) for the correct wiring.
- HDMI** Connect the local sink device (e.g. a monitor) to the HDMI output port by an HDMI cable.
- USB** Optionally for USB HID extension: connect the transmitter to the computer by the USB mini B-type cable.
- RS-232** Optionally for RS-232 control: connect a controller/controlled device (e.g. a touch panel) to the RS-232 port.
- LAN** Optionally connect the switcher to a LAN network in order to control the device.
- GPIO** Optionally connect a controller/controlled device (e.g. relay box) to the GPIO port.
- Power** Connect the power adaptor to the DC input of the transmitter first, then to the AC power socket.

# 3

## Product Overview

The following sections are about the physical structure of the device, input/output ports and connectors:

- ▶ [FRONT VIEW - TRANSMITTER](#)
- ▶ [REAR VIEW - TRANSMITTER](#)
- ▶ [FRONT AND REAR VIEW - RECEIVER](#)
- ▶ [ELECTRICAL CONNECTIONS](#)
- ▶ [OPTICAL EXTENDER CONCEPT](#)
- ▶ [PORT DIAGRAMS](#)
- ▶ [AUDIO INTERFACE](#)
- ▶ [VIDEO INTERFACE](#)
- ▶ [THE AUTOSELECT FEATURE](#)
- ▶ [USB KVM FUNCTION](#)
- ▶ [CONTROLLING FEATURES](#)
- ▶ [FURTHER BUILT-IN FEATURES](#)

### 3.1. Front View - Transmitter

HDMI-3D-OPT-TX210A

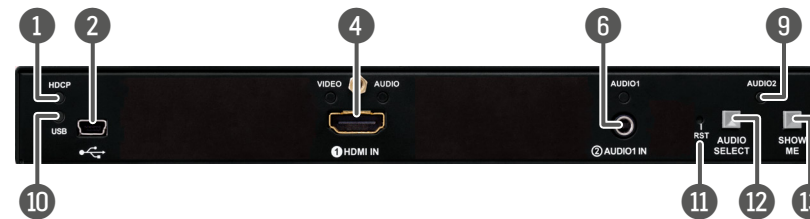

HDMI-3D-OPT-TX210RAK

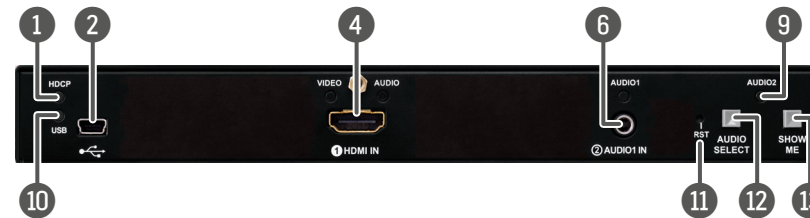

SW4-OPT-TX240RAK

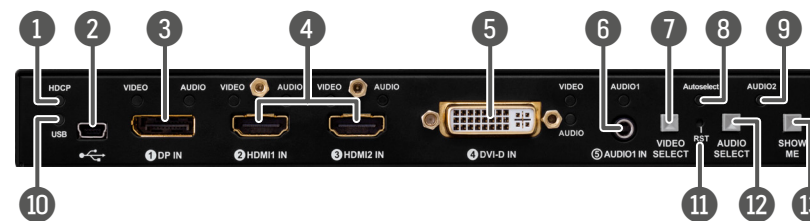

- 1 **HDCP status LED** LED gives feedback about the HDCP status of the video output signal. See details in the [HDCP LED](#) section.
- 2 **USB connector** USB interface for LDC connection, firmware upgrade purpose, and USB KVM function.
- 3 **DisplayPort input** DisplayPort connector for DisplayPort audio/video signal.
- 4 **HDMI input** HDMI connector for DVI video or HDMI video and audio.

- 5 **DVI-D input** DVI-I connector for DVI-D video and audio.
- 6 **Audio1 input** 3.5 mm Jack connector for asymmetric analog audio input signal.
- 7 **Video Select button** Button for switching between video sources. See the details in the [Video Select Button](#) section.
- 8 **Autoselect status LED** LED gives feedback about the status of Autoselect feature. See the details in the [Autoselect LED](#) section.
- 9 **Audio2 status LED** LED gives feedback about actual connection status of Audio2 input port (on the rear side of device).
- 10 **USB LED** LED gives feedback about the status of USB operations (LDC control, firmware upgrade, and USB KVM function). See the details in the [USB LED](#) section.
- 11 **Reset button** Reset button reboots the extender. This is the same as disconnecting the device from the power source and reconnecting it again.
- 12 **Audio Select button** Button for switching between audio sources. See the details in the [Audio Select Button](#) section.
- 13 **Show Me button** Special functions are available with this button (switch to bootload mode, enable DHCP, restore factory default settings, condition launching in [Event Manager](#)). For the details about special functions see the [Special Functions - Transmitter](#) section.

**INFO:** Operation of the audio and video status LEDs can be found in the [Video Input LEDs](#) and the [Audio Input LEDs](#) sections.

### 3.2. Rear View - Transmitter

HDMI-3D-OPT-TX210A

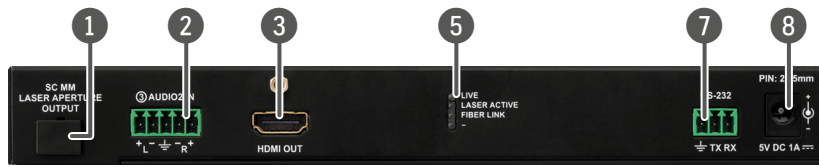

HDMI-3D-OPT-TX210RAK

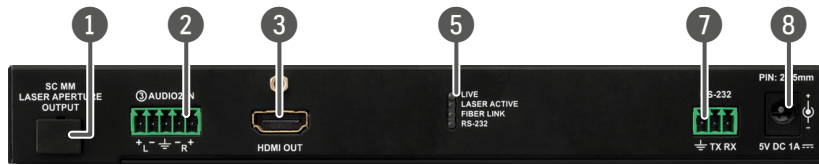

SW4-OPT-TX240RAK

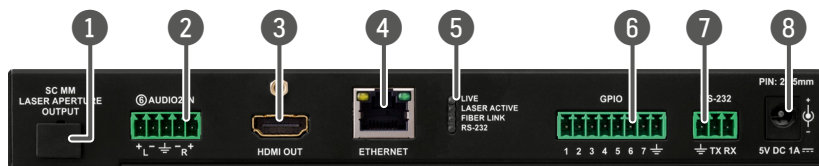

**1 SC fiber output**

Connect a multimode single fiber optical cable between the transmitter and the receiver unit. Maximum fiber cable distances can be found in the [Maximum Fiber Cable Extensions](#) section.

**2 Audio2 input**

5-pole Phoenix connector for balanced analog audio input signal. Pin assignment can be found in the [Analog Stereo Audio Connector \(5-pole Phoenix\)](#) section.

**3 HDMI output**

Local HDMI output with the same A/V content as the fiber optical output.

**4 Ethernet**

Locking RJ45 connector for configuring the device using Lightware Device Controller (LDC). Any third-party control system can use this port to control the device.

**5 Status LEDs**

The LEDs give immediate feedback about actual state of the device. See the details in the [Rear Panel Status LEDs - Transmitter](#) section.

**6 GPIO**

8-pole Phoenix connector for configurable general purpose input/output ports. Pin assignment can be found in the [GPIO - General Purpose Input/Output Ports](#) section.

**7 RS-232**

3-pole Phoenix connector for RS-232 serial port. Pin assignment can be found in the [RS-232 Connector \(3-pole Phoenix\)](#) section.

**8 5V DC input**

Local power in; connect the output of the supplied 5V DC power adaptor. For more information see the [5V DC Connection](#) section.

**5 Status LEDs**

The LEDs give immediate feedback about actual state of the device. See the details in the [Status LEDs](#) section.

**6 RS-232**

D-sub connector for RS-232 serial port.

**7 5V DC input**

Local power in; connect the output of the supplied 5V DC power adaptor. For more information see the [5V DC Connection](#) section.

**8 SC fiber input**

Connect a multi-mode single fiber optical cable between the receiver and the transmitter unit. Maximum fiber cable distances can be found in the [Maximum Fiber Cable Extensions](#) section.

**9 S/PDIF output**

S/PDIF connector for digital audio output signal.

**10 Analog audio output**

5-pole Phoenix connector for balanced analog audio output signal. Pin assignment can be found in the [Analog Stereo Audio Connector \(5-pole Phoenix\)](#) section.

**11 HDMI output**

HDMI connector for DVI video or HDMI video and audio.

### 3.3. Front and Rear View - Receiver

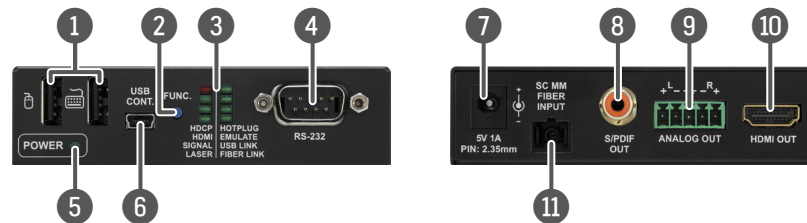

**1 USB KVM ports**

USB KVM ports for HID-compatible devices (preferably keyboard and mouse). See more information in the [USB KVM Function](#) section.

**2 Power LED**

The LED indicates the power status of the device. See the details in the [POWER LED](#) section.

**3 USB control port**

USB interface for LDC connection, and firmware upgrade purpose.

**4 Function button**

Factory default settings and bootload mode can be called using the button. See the details in the [Special Functions - Receiver](#) section.

### 3.4. Electrical Connections

#### 3.4.1. 5V DC Connection

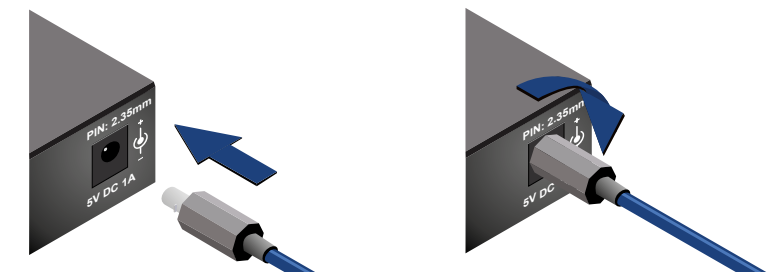

**Locking DC connector**

The extenders are built with locking 5V DC connector. Do not forget to turn the plug clockwise direction before disconnecting the power adaptor.

**WARNING! Always use the supplied 5V power adaptor. Warranty void if damage occurs due to use of a different power source.**

### 3.4.2. HDMI Connector

The extenders provide standard 19-pole HDMI connector for input and output. Always use high-quality HDMI cable for connecting sources and displays.



### 3.4.3. DVI-I Connector

SW4-OPT-TX240RAK transmitter provides 29-pole „digital only” DVI-I Dual-Link connectors (only digital pins are internally connected) for input and local output. This way, users can plug in any DVI connector, but keep in mind that analog signals (such as VGA or RGBHV) are not processed.

Always use high-quality DVI cable for connecting sources and displays.



Pin	Signal	Pin	Signal
1	TMDS Data2-	16	Hot Plug Detect
2	TMDS Data2+	17	TMDS Data0-
3	TMDS Data2 Shield	18	TMDS Data0+
4	Not connected	19	TMDS Data0 Shield
5	Not connected	20	Not connected
6	DDC Clock	21	Not connected
7	DDC Data	22	TMDS Clock Shield
8	Not connected	23	TMDS Clock+
9	TMDS Data1-	24	TMDS Clock-
10	TMDS Data1+	C1	Not connected
11	TMDS Data1 Shield	C2	Not connected
12	Not connected	C3	Not connected
13	Not connected	C4	Not connected
14	+5V Power	C5	GND
15	GND (for +5V)		

### 3.4.4. DisplayPort Connector

SW4-OPT-TX240RAK transmitter provides standard 20-pole DisplayPort connector for input. Always use high quality DP cable for connecting DisplayPort devices.



### 3.4.5. SC Fiber Optical Connector

HDMI-3D-OPT series transmitters and receivers provide multimode SC fiber optical input and output connectors.



Maximum fiber cable distances can be found in the [Maximum Fiber Cable Extensions](#) section.

**WARNING! Please do not look directly into the SC fiber optical connector if the cable is connected to the transmitter only and the laser is active.**

### 3.4.6. Analog Stereo Audio Connector (3.5 mm Jack)

The connector is used for receiving unbalanced analog audio signal. It is also known as (3.5 mm or approx. 1/8”) audio jack, phone jack, phone plug and mini-jack plug.

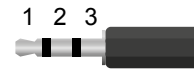

Pin nr.	Signal
1	Left
2	Right
3	Ground

**Jack audio plug pin assignments**

You can find more information about audio functions in the [Audio Interface](#) section.

### 3.4.7. Analog Stereo Audio Connector (5-pole Phoenix)

5-pole Phoenix connector is used for balanced analog audio output. Unbalanced audio signals can be connected as well. For unbalanced output connect + and ground to the source and connect - to the ground.

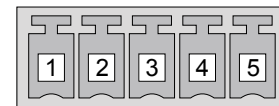

Pin nr.	Signal
1	Left+
2	Left-
3	Ground
4	Right-
5	Right+

**Analog audio connector and plug pin assignments**

#### Compatible Plug Type

Phoenix® Combicon series (3.5mm pitch, 5-pole), type: MC 1.5/5-ST-3.5.

You can find more information about analog audio function in the [Audio Interface](#) section. Audio cable wiring guide is in the [Audio Cable Wiring Guide](#) section.

### 3.4.8. S/PDIF Connector

HDMI-3D-OPT-RX150RA receiver provides standard RCA receptacles for digital coaxial audio outputs.



You can find more information about audio functions in the [Audio Interface](#) section.

### 3.4.9. RS-232 Connector (3-pole Phoenix)

The extender contains a 3-pole Phoenix connector which is used for RS-232 serial connection.

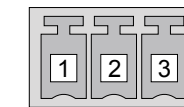

Pin nr.	Signal
1	Ground
2	TX data
3	RX data

**RS-232 connector pin assignments**

#### Compatible Plug Type

Phoenix® Combicon series (3.5mm pitch, 3-pole), type: MC 1.5/3-ST-3.5.

You can find more information about RS-232 interface in the [Serial Interface](#) section.

### 3.4.10. RS-232 Connector (D-sub)

HDMI-3D-OPT-RX150RA receiver contains RS-232 port which can be connected by an industry standard 9-pole D-sub female connector.

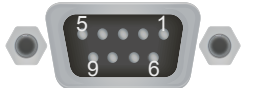

Pin nr.	RS-232 pin-out
1	Not connected
2	<b>TX data transmit (output)</b>
3	<b>RX data receive (input)</b>
4	DTR (Internally connected to Pin 6)
5	<b>GND signal ground (shield)</b>
6	DSR (Internally connected to Pin 4)
7	RTS (Internally connected to Pin 8)
8	CTS (Internally connected to Pin 7)
9	Not connected

You can find more information about RS-232 interface in the [Serial Interface](#) section.

### 3.4.11. Ethernet Connector

The extender provides standard RJ45 connectors for LAN port. Always use high quality Ethernet cable for connecting transmitters and receivers.

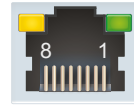

#### Wiring LAN Cables

Lightware recommends the termination of LAN cables on the basis of TIA/EIA T 568 A or TIA/EIA T 568 B standards.

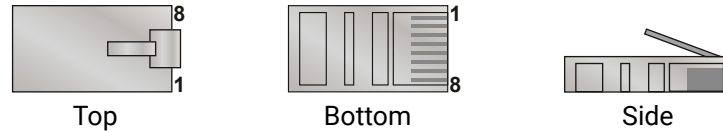

Pin	TIA/EIA T568 A	Color and name	TIA/EIA T568 B	Color and name
1		white/green stripe		white/orange stripe
2		green solid		orange solid
3		white/orange stripe		white/green stripe
4		blue solid		blue solid
5		white/blue stripe		white/blue stripe
6		orange solid		green solid
7		white/brown stripe		white/brown stripe
8		brown solid		brown solid

Pin assignments of RJ45 connector types

### 3.4.12. USB Mini Connector

The extenders provide standard USB mini B-type connector for software control and USB KVM purposes.



You can find more information about USB KVM function in the [USB KVM Function](#) section.

### 3.4.13. USB Connector for KVM

HDMI-3D-OPT-RX150RA receiver provides USB 2.0 connectors for KVM function supporting purpose. The unit has 2x USB 2.0 A-type connectors.



You can find more information about USB KVM function in the [USB KVM Function](#) section.

### 3.4.14. GPIO - General Purpose Input/Output Ports

SW4-OPT-TX240RAK transmitter contains a 8-pole Phoenix connector with seven GPIO pins, which operates at TTL digital signal levels and can be set to high or low level (Push-Pull). The direction of the pins can be input or output (adjustable). Voltage ranges for GPIO inputs are the following:



	Input voltage [V]	Max. current [mA]
Logical low level	0 - 0,8	30
Logical high level	2 - 5	18

INFO: The maximum total current for the seven GPIO pins is 180 mA.

Pin nr.	Level and direction
1	Configurable
2	
3	
4	
5	
6	
7	
Ground	

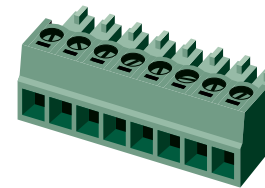
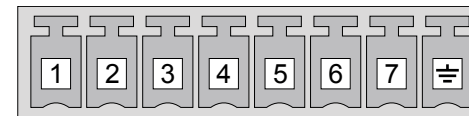

GPIO connector and plug pin assignments

#### Compatible plug type

Phoenix® Combicon series (3.5mm pitch 8-pole), type: MC 1.5/8-ST-3.5.

You can find more information about GPIO interface in the [GPIO Interface](#) section.

## 3.5. Optical Extender Concept

### 3.5.1. Transmitter

HDMI-3D-OPT-TX200 series transmitters have a multimode single fiber output interface which is able to transmit different type of signals at the same time. The transmitter accepts digital video (DP, HDMI, and DVI-D) and analog audio sources (Jack and 5-pole Phoenix). The device can be controlled over LAN, RS-232 (3-pole Phoenix), and USB interfaces. The transmitter is able control third-party devices using the built-in GPIO ports. The transmitter also has USB KVM function.

#### Interfaces of HDMI-3D-OPT-TX210A



#### Interfaces of HDMI-3D-OPT-TX210RAK



#### Interfaces of SW4-OPT-TX240RAK



### 3.5.2. Receiver

HDMI-3D-OPT-RX150RA receiver has a multi-mode single fiber input interface which is able to receive different type of signals at the same time. The device accepts digital video and digital/analog audio, RS-232, and USB KVM signals over a single fiber cable. The device is able to deembed the audio signal to the analog (5-pole Phoenix) and the digital (S/PDIF) ports and transmit it to the audio source devices. The unit can be controlled via USB interface (USB mini B-type) and built with a bidirectional RS-232 port (D-sub). The device also has USB KVM function.

#### Interfaces of HDMI-3D-OPT-RX150RA

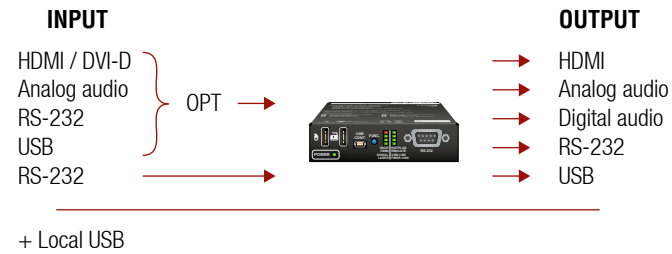

### 3.6. Port Diagrams

The following diagrams introduce the route of the different signal types (including the audio/video and control signals as well) from the input to the output ports in the device.

#### HDMI-3D-OPT-TX210A

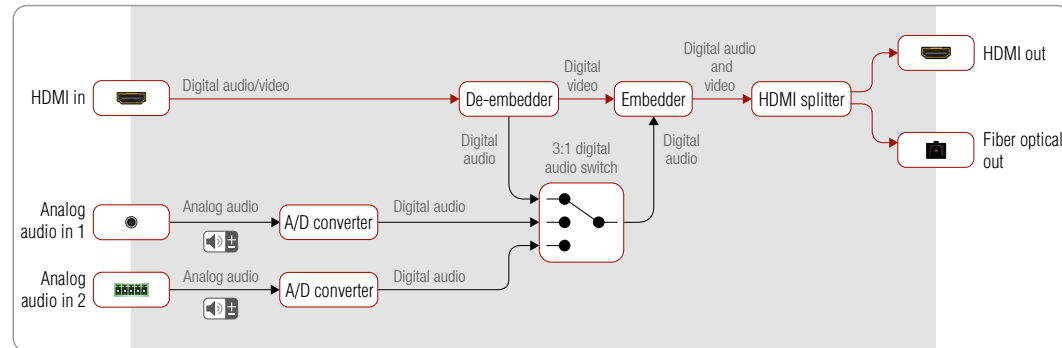

#### HDMI-3D-OPT-TX210RAK

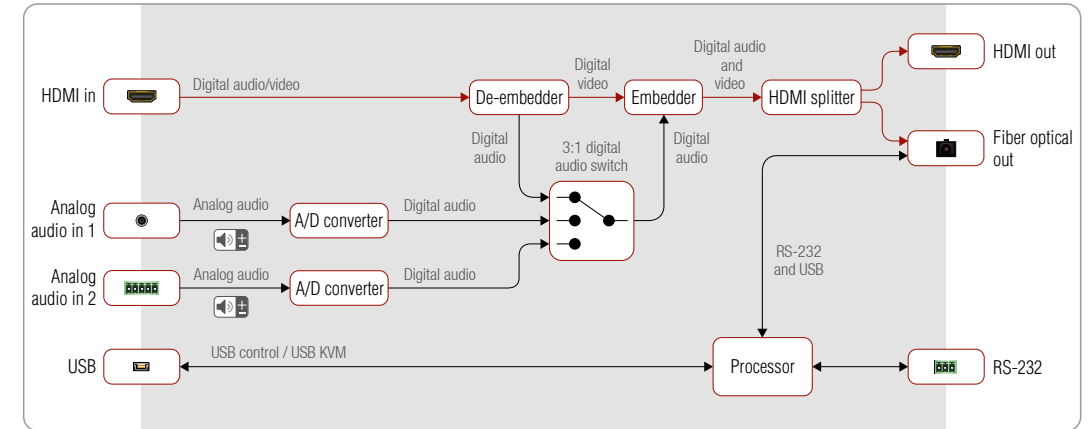

#### SW4-OPT-TX240RAK

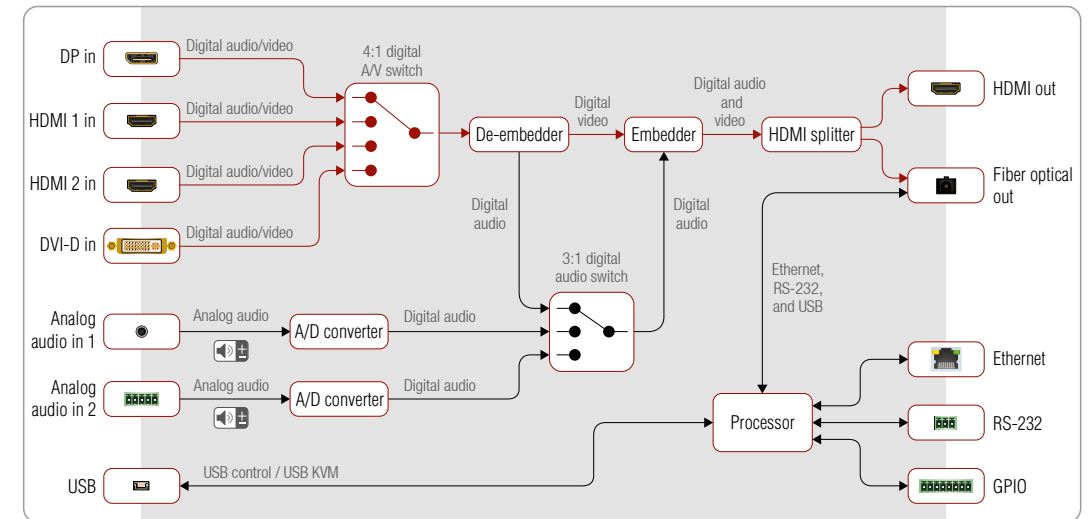



## HDMI-3D-OPT-RX150RA

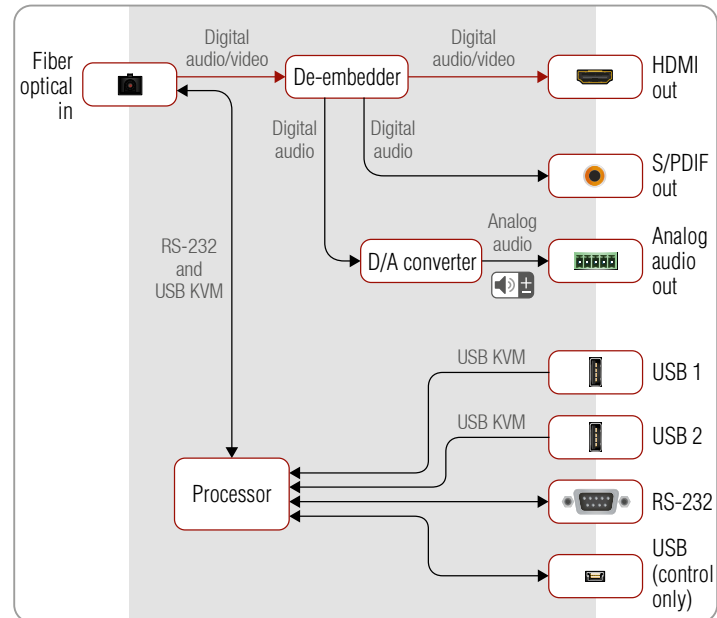

## 3.7. Audio Interface

### 3.7.1. Audio Inputs and Modes - Transmitter

The transmitter can receive audio from two type of sources:

- Embedded (2x HDMI, 1x DP, 1x DVI-D);
- Analog audio sources (1x Jack and 1x 5-pole Phoenix).

The audio coming from the analog inputs can be assigned to any video input. The gain levels of the analog audio input and the volume of the analog audio output ports are adjustable.

#### Audio Embedding – Allowed Connections

When the desired video signal is selected, the audio of the transmitted signal can be:

- The audio of the original signal, or
- The analog audio signal.

**INFO:** In case of SW4-OPT-TX240RAK model the audio of the HDMI 2 input can be embedded only in the original video stream. The audio of HDMI1 input cannot be mixed with the video of HDMI 2 input and vice versa.

### 3.7.2. Audio Outputs and Modes - Receiver

The receiver can transmit audio on three types of audio ports:

- Embedded (HDMI);
- Digital audio (S/PDIF);
- Analog balanced audio (5-pole Phoenix).

The digital audio signal coming from the the optical input port can be transmitted on any audio output ports: HDMI, S/PDIF, or the analog audio output port. The volume and balance levels are adjustable on the analog output port.

#### Supported Audio Formats

The table below shows the supported audio formats by output ports.

Audio formats	Audio outputs		
	Embedded audio	S/PDIF output	Analog audio output
Multichannel PCM	Max 8 channel (up to 192 kHz)	Stereo PCM (up to 48 kHz)	Stereo PCM (up to 48 kHz)
Dolby Digital 2.1	✓	✓	-
Dolby Digital 5.1	✓	✓	-
Dolby Digital 7.1	✓	✓	-
DTS 2.1	✓	✓	-
DTS 5.1	✓	✓	-
DTS 7.1	✓	✓	-
Dolby TrueHD (HBR)	✓	-	-
DTS-HD (HBR)	✓	-	-
DTS-HD Master Audio (HBR)	✓	-	-
All other HDMI specified standards	✓	-	-

### 3.7.3. Audio Options - Example

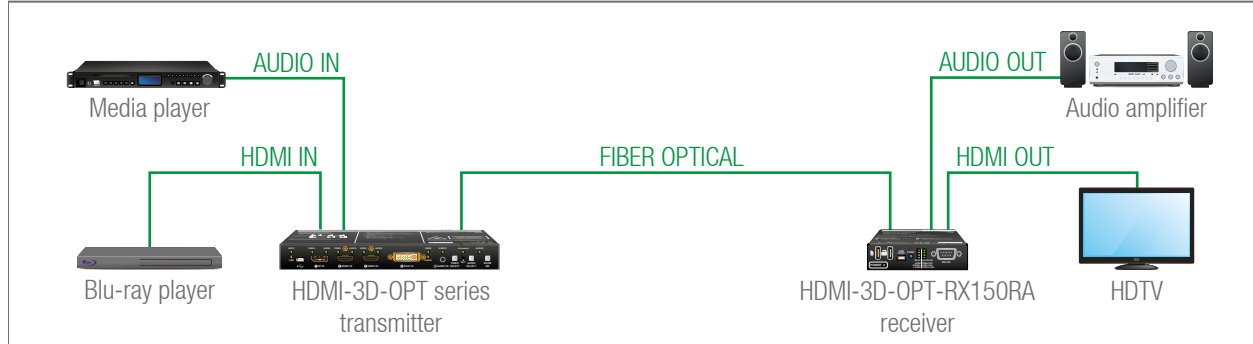

#### The Concept

Two audio source devices are connected to the transmitter: a Blu-ray player which has embedded digital audio on HDMI; and a media player which sends analog audio to the transmitter. On the receiver's side there is two audio source device: an HDTV which can receive digital audio on HDMI; and an audio amplifier which can receive analog or digital audio signals as well.

As the transmitter is able to embed the analog audio signal to the HDMI signal, the user can transmit the audio of the Blu-ray player or the audio of the media player as well.

**INFO:** One audio (embedded or analog) and one video signals can be transmitted via the optical output at the same time.

The receiver has built-in de-embedder function so the user can transmit audio signal to the audio amplifier and HDTV as well.

All related audio settings are available in the Lightware Device Controller software, see the [Port Properties Windows](#) section.

### 3.8. Video Interface

#### Transmitter

The video crosspoint settings can be controlled by any of the following ways:

- Pressing **Video Select** button on the device,
- Using Lightware Device Controller (LDC),
- Sending LW2 or LW3 protocol commands, or
- Using the **Autoselect** function.

**INFO:** The audio/video signal on the local HDMI output port is always the same as on the optical output port.

#### Direct Selection on SW4-OPT-TX240RAK Transmitter

Desired video input can be selected by the **Video select** button, the order is the following:

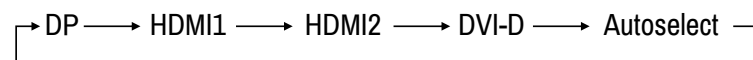

### 3.9. The Autoselect Feature

Beside of manual selecting of crosspoints you can choose the Autoselect option both in case of audio and video ports.

There are three types of Autoselect as follows.

- First detect mode:** selected input port is kept connected to the output while it has an active signal.
- Priority detect mode:** always the highest priority active input is selected to transmit.
- Last detect mode:** always the last attached input is selected to transmit.

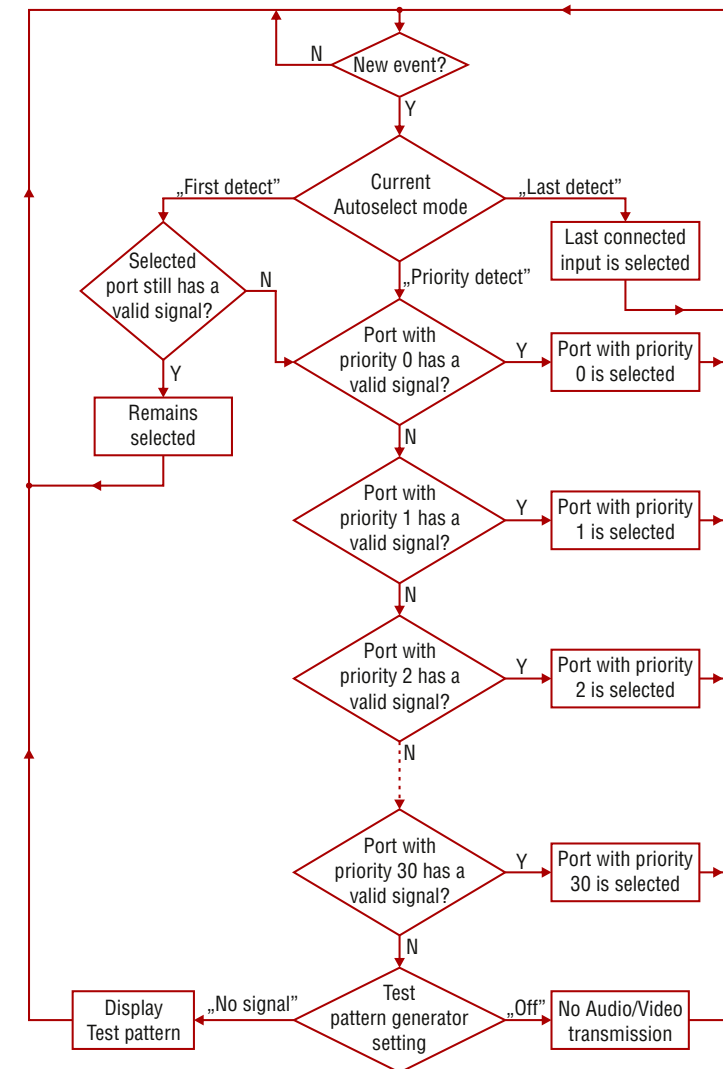

**Flowchart of Autoselection modes**

### Automatic Input Selection - Example

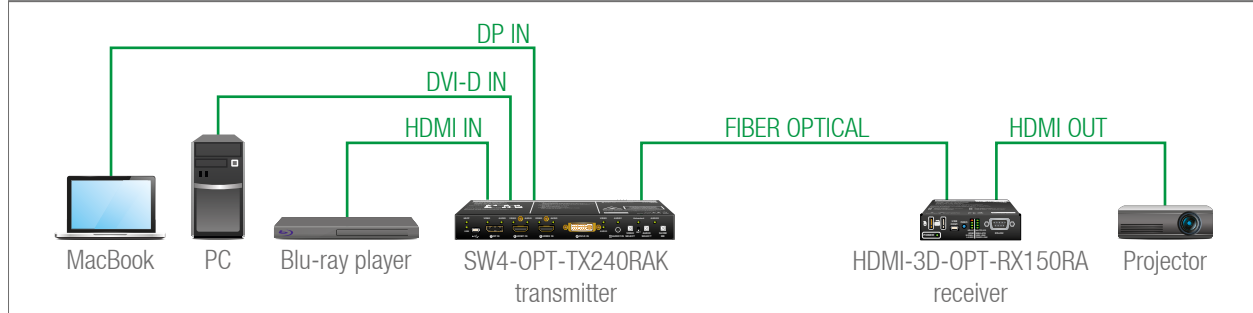

#### The Concept

If there is no other source connected to the transmitter, but the MacBook, DP input will be automatically switched to the optical output. If the MacBook and the PC are also connected to the transmitter, DVI-D input will be switched to the optical output. If the Blu-ray player is connected on the HDMI input of the transmitter, it will be switched to the optical output – independently of the presence of other video signals.

#### Settings

- **Optical output:** Set the Autoselect to **Enabled**. Set Autoselect mode to Priority detect. The priorities are the following (the lowest number means the highest priority): The priorities are the followings:

Source device	Input port	Priority
MacBook	I1 (DP IN)	2
PC	I4 (DVI-D IN)	1
Blu-ray player	I2 (HDMI IN)	0

Priorities can be set in Lightware Device Controller software, see related settings in the [Video Outputs](#) and [Digital Audio Outputs](#) sections.

### 3.10. USB KVM Function

HDMI-3D-OPT-TX210RAK, SW4-OPT-TX240RAK, and the HDMI-3D-OPT-RX250RA extenders support HID-compliant (Human Interface Device) devices to transmit USB signal between the source and sink devices. The transmitter connects to the controlled device (e.g. PC) and the controlling devices (e.g. computer mouse, keyboard, touch panel) are connected to the receiver.

**ATTENTION!** Only HID-compliant devices are supported by the extenders. Non-HID devices (USB sticks, webcams, etc) will not be working with the extenders.

USB KVM function can be used in two different modes: **Transparent** and **Composite mode**. The following sections show the difference between the two modes:

#### Transparent Mode

Transparent mode is a simple USB data transmission between the extenders. The same data is transmitted on the TX side which is received on the RX side. The content of the transmitted packets are unknown to the Lightware infrastructure so the data is not modified by any means during the transmission.

#### Key Features:

- Supports all HID-compliant devices.
- Driver software for all connected USB devices has to be installed on the controlled computer. When you switch a crosspoint between two sources, the connected mouse and keyboard will be detected as a new hardware in the operating system.

#### Composite Mode

The composite mode is an advanced data transmission method, recommended for most users. The devices use their own data packets during data transmission. Thus, the content of the transmitted packets is known to the Lightware infrastructure.

#### Key Features:

- Supports the following HID-compliant devices: computer mouse, keyboard built with 107 keys and/or specific multimedia keys.
- No driver software is needed for the connected devices. The operating system uses the driver of the extender to establish the connection for the USB devices.

INFO: You can find the related settings for Lightware Device Controller software in the [USB KVM](#) section.

#### USB KVM - Example 1

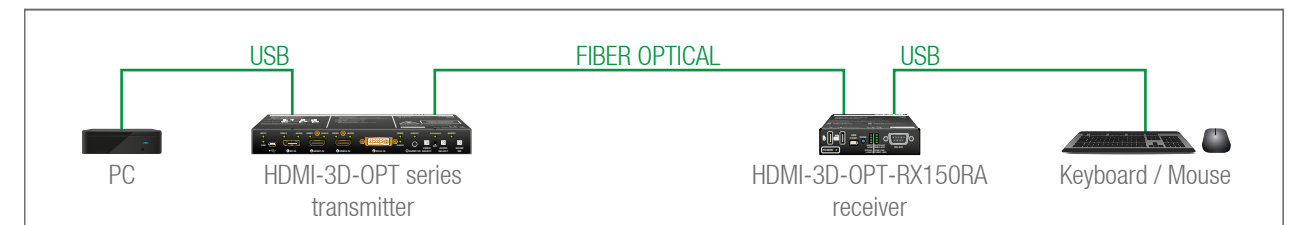

#### The Concept

The PC is connected to the transmitter with a USB cable. The signal is transmitted over the fiber optical line from the receiver which is connected to the controller devices (to the keyboard and the mouse) to the transmitter. The physical distance between the controlled PC and the controller devices can be up to 2500 meters.

### USB KVM - Example 2

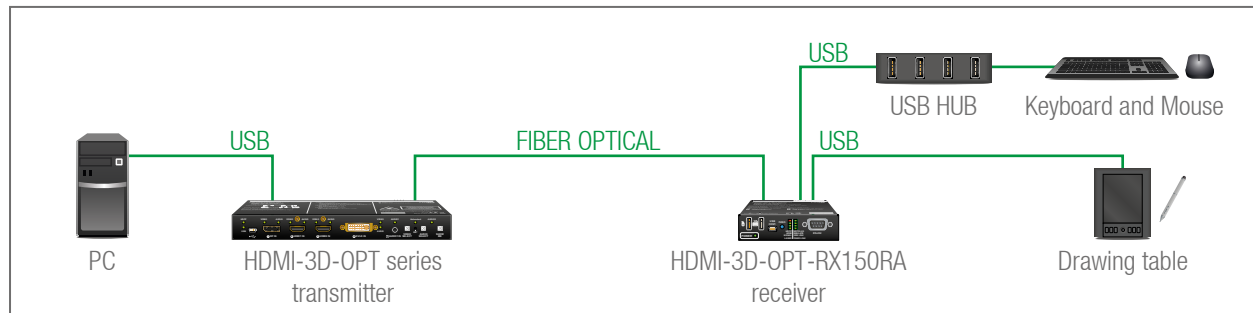

#### The Concept

Two devices are connected to the USB ports of the Receiver:

- A **Drawing table**;
- A **USB HUB** which has four USB ports - a **Keyboard** and a **Mouse** are connected to the HUB.

The PC can be controlled by the keyboard and the mouse, as well as the drawing table is also working as an input device beside of them.

#### Settings:

- **Keyboard and mouse (via the USB HUB):** the devices need to be set to **Composite** mode. The extenders can handle both of them if the devices are HID-compliant computer mouse and/or keyboard built with 107 keys and/or specific multimedia keys.
- **Drawing table:** the device needs to be set to **Transparent** mode because this kind of devices may have special functions which cannot be supported by the composite mode.

All related settings are available in the LDC software, see the [USB KVM](#) section.

INFO: The extenders support up to 8 physical USB HUB ports.

## 3.11. Controlling Features

The interfaces of the HDMI-3D-OPT series extenders can be used to install the device at various point of a complex A/V system. Besides, the transmitter and the receiver are able to handle controlling functions. This section is about to present the possibilities through the control ports built-in the the extenders.

### 3.11.1. Serial Interface

INFO: Only HDMI-3D-OPT-TX210RAK and SW4-OPT-TX240RAK transmitters, and HDMI-3D-OPT-RX150RA receiver have RS-232 interface.

#### Technical Background

Serial data communication can be established via the local RS-232 port (Phoenix connector) or via the optical line. The RS-232 ports – which are connected to the processor (CPU) – can be configured separately (e.g. if the Baud rates are different, the microcontroller does the conversion automatically between the ports). The RS-232 port can be switched to Control mode, Command Injection mode, or can be Pass-through mode; see the following figure.

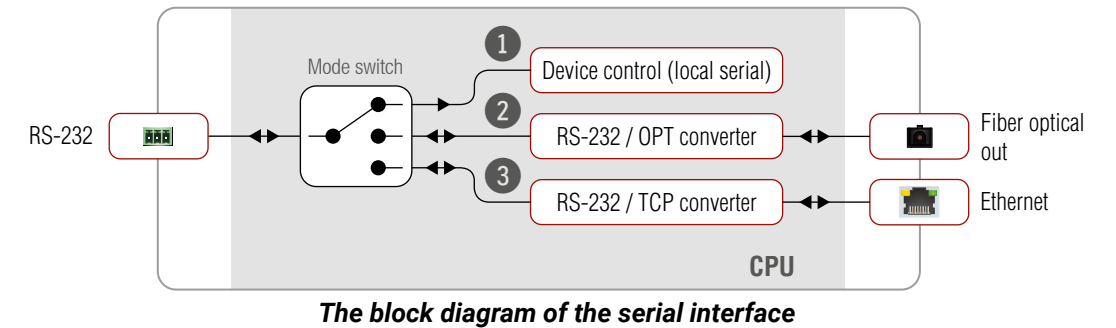

The following settings are defined:

- 1 The Local serial port is in **Control mode**.
- 2 The Local serial port is in **Pass-through mode**.
- 3 The Local serial port is in **Command Injection mode**.

All settings are available in the LDC software, see settings in the [RS-232](#) section.

#### Control Mode

The incoming data from the given port is processed and interpreted by the CPU. The mode allows to control the matrix directly. LW2 or LW3 protocol commands are accepted – depending on the current port setting.

#### Pass-through Mode

In pass-through mode, the given device forwards the data that is coming from one of its ports to another same type of port. The command is not processed by the CPU. Incoming serial data is forwarded from one port to another port inside the extender.

#### Command Injection Mode

INFO: HDMI-3D-OPT-RX150RA receiver has no command injection mode.

In this mode, the extender works as a TCP/IP <-> RS-232 bidirectional converter. The TCP/IP data signal is converted to RS-232 data and vice versa. TCP/IP port numbers are defined for the serial ports (optical link and local) for this purpose. E.g. the default Command Injection port number of the local RS-232 port is 8001. If data is coming from the optical interface which addresses to the port no. 8001, it will be transmitted to the Tx pin of the local RS-232 port. That also works in the opposite direction of course and the method is the same on the serial interface of the optical port as well.

### RS-232 Signal Transmission - Example 1

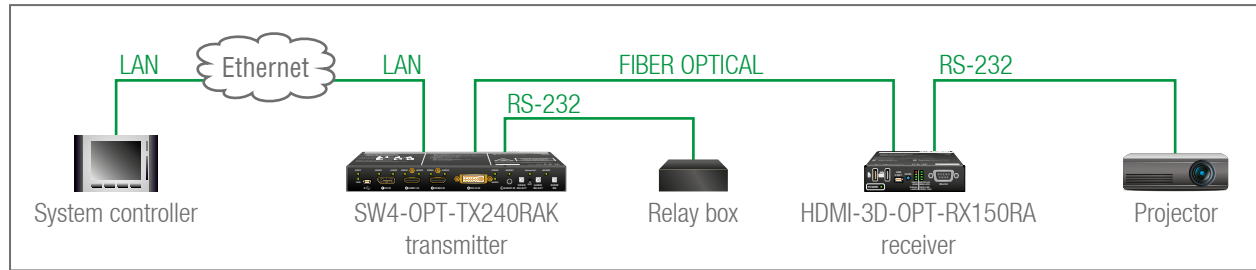

The following ways are available for controlling the devices:

- The **System controller** can communicate with the **Transmitter** by LW2/LW3 protocol commands sent to the local IP:port address.
- The **System controller** can communicate directly with the **Projector** or an **Extender** via their IP:port address.
- The **System controller** can communicate directly with the RS-232 **Relay box** connected to the **Transmitter**. In this case, **Command Injection** mode has to be enabled on the local RS-232 port.
- The **Transmitter** can send a command (e.g. as an action by the Event Manager) to the IP:port address of the **Projector** or the **Receiver** by using LW3 protocol methods.

#### Command Sending

- You can send LW3 protocol commands to the **192.168.0.100:6107** port to control the transmitter.
- You can send LW2 protocol commands to the **192.168.0.100:10001** port to control the transmitter.
- You can send commands to the **192.168.0.100:8001** port to control the projector. This port number means the RS-232 interface of the optical output port (O1).

INFO: Above values are examples and based on factory default settings.

INFO: Only SW4-OPT-TX240RAK model has Ethernet LAN port.

### RS-232 Signal Transmission - Example 2

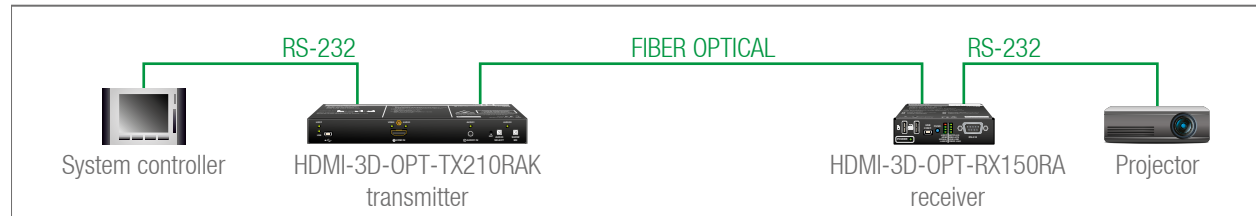

#### The Concept

You can control the **Projector** over the extenders with the **System controller**. The controller is connected to the local RS-232 port of the **Transmitter** which transmits the signal toward the **Receiver** over the fiber optical line. The **Projector** is connected to the local RS-232 port of the **Receiver**. The serial connection is bidirectional which means the controller gets back the responses of the projector.

In this case the RS-232 port of the transmitter and receiver either has to be set to **Pass-through mode**.

### 3.11.2. GPIO Interface

INFO: Only SW4-OPT-TX240RAK model has GPIO interface.

The GPIO (General Purpose Input/Output) port is a multifunctional input/output interface to control the SW4-OPT-TX240RAK transmitter or third-party devices and peripherals. You can establish connection between the controller/controllable device and the transmitter by the 8-pole Phoenix connector. The derivation of the seven pin is configurable independently based on the purpose of the application.

#### GPIO Options - Example

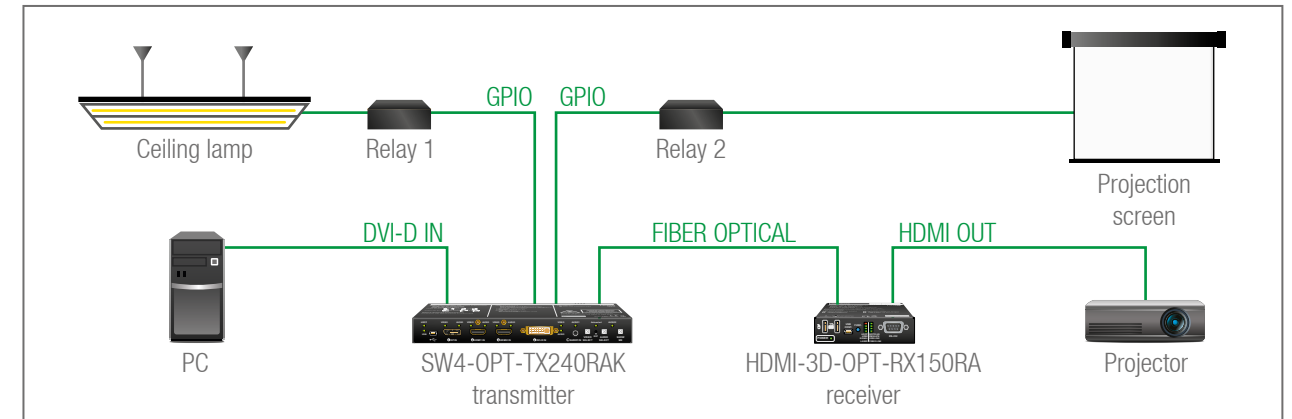

#### The Concept

Ceiling lamp is turned off by Relay 1 and projection screen is rolled down by Relay 2 when signal received from the PC over the DVI-D input. Both relays are controlled by the GPIO port.

#### Settings of the Transmitter

- **For Relay 1:** create an event in Event Manager: when signal is present on Input 1 (I1) then set GPIO pins to low level for Relay 1 opening. Also create another event when signal is not present on Input 1 (I1) then set GPIO pins to high level for Relay 1 closing.
- **For Relay 2:** create an event in Event Manager when signal is present on Input 1 (I1) then set GPIO pins to high level for Relay 2 closing. Also create another event when signal is not present on Input 1 (I1) then set GPIO pins to low level for Relay 2 opening.

When the PC starts to play the video presentation, the signal is received over the DVI-D input so GPIO pins send signal to Relay 1 to open which results turning off the lights. Furthermore GPIO pins also send signal to Relay 2 to close and the projection screen is rolled down. When the presentation is ended, signal ceases on the DVI-D input, so GPIO pins send signal to Relay 1 to close which results turning on the lights and sends signal to Relay 2 to open so projection screen returns to its enclosure.

**ATTENTION!** Please always check the electrical parameters of the devices what you want to control. The maximum current of one GPIO pin is 30 mA, the maximum total current for the seven pins is 180 mA.

See the LDC settings for GPIO port in the [GPIO](#) section. See also the details about the Event Manager settings in the [Event Manager](#) section.

### 3.11.3. USB Control Interface

The device can be controlled over front panel USB mini B-type connector. This interface only supports LW3 protocol. The interface can be used to establish the connection to Lightware Device Controller software.

### 3.11.4. Ethernet Control Interface

INFO: Only SW4-OPT-TX240RAK model has Ethernet control interface.

The device can be controlled over rear panel standard RJ45 connector. The interface can be used to establish the connection to Lightware Device Controller software.

## 3.12. Further Built-in Features

### 3.12.1. Automatically Launched Actions - The Event Manager

The Event Manager feature means that the device can sense changes on its ports and is able to react according to the pre-defined settings. Lightware Device Controller contains a user-friendly software tool and allows to create Events by defining a Condition and an Action.

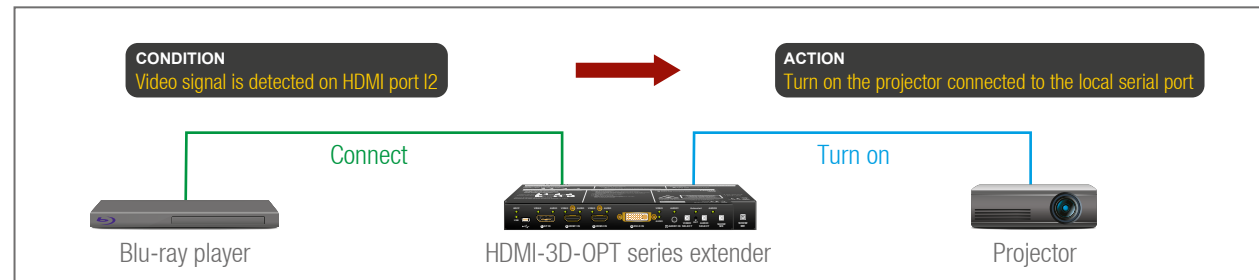

*Event Manager example*

See more information about the settings in the [Event Manager](#) section.

### 3.12.2. Advanced EDID Management

#### Factory Preset EDIDs

The factory EDIDs (F1-F136) are factory preprogrammed and cannot be modified. These are the most common resolutions. They are specially provided to force graphic cards to output only the exact pixel resolution and refresh rate.

Universal EDID allows multiple resolutions including all common VESA defined resolutions. The use of universal EDID is recommended for fast and easy system setup.

### Sources and Destinations

The EDID memory consists of four parts:

- **Factory EDID** list shows the pre-programmed EDIDs (F1-F136).
- **Dynamic EDID** list shows the display device connected to the device's outputs. The unit stores the last display devices' EDID on either output, so there is an EDID shown even if there is no display device attached to the output port at the moment.
- **User memory** locations (U1 – U14 for the transmitter; U1 – U15 for the receiver) can be used to save custom EDIDs.
- **Emulated EDID** list shows the currently emulated EDID for the inputs. The source column displays the memory location that the current EDID was routed from.

The source reads the EDID from the Emulated EDID memory on the INPUT port. Any EDID from any of the User/Factory/Dynamic EDID lists can be copied to the user memory.

There are two types of emulation: **static** and **dynamic**.

- **Static EDID emulation:** an EDID from the Factory or User EDID list is selected. Thus, the Emulated EDID remains the same until the user emulates another EDID.
- **Dynamic EDID emulation:** it can be enabled by selecting D1 or D2 EDID memory. The attached monitor's EDID is copied to the input; if a new monitor is attached to the output, the emulated EDID changes automatically.

See more information about the settings in the [EDID Menu](#) section.

### 3.12.3. Extender Cloning – Configuration Backup and Restore

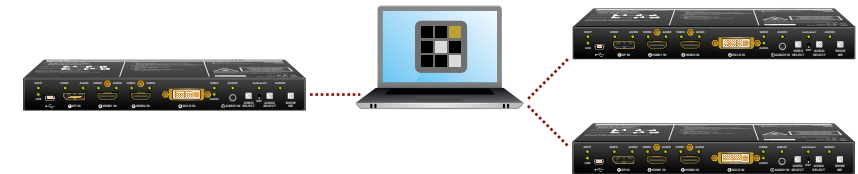

The configuration cloning of HDMI-3D-OPT series devices is a simple method that eliminates the need to repeatedly configure certain devices to have identical (non-factory) settings. If the devices are installed in the same type of system multiple times then it is enough to set up only one device to fit the user's needs and then copy those settings to the others, thus saving time and resources.

See more information about the settings in the [Configuration Cloning \(Backup Tab\)](#) section.

# 4

## Operation

This chapter is about the powering and operating of the device describing the functions which are available by the front/rear controls:

- ▶ FRONT PANEL LEDs - TRANSMITTER
- ▶ FRONT PANEL BUTTONS - TRANSMITTER
- ▶ SPECIAL FUNCTIONS - TRANSMITTER
- ▶ REAR PANEL STATUS LEDs - TRANSMITTER
- ▶ FRONT PANEL LEDs - RECEIVER
- ▶ SPECIAL FUNCTIONS - RECEIVER
- ▶ SOFTWARE CONTROL MODES

### 4.1. Front Panel LEDs - Transmitter

#### 4.1.1. Video Input LEDs



- OFF:** The video source is not selected.
- BLINKING:** The video source is selected but signal is not detected.
- ON:** The video source is selected and signal is detected.

**INFO:** When Autoselect is enabled and video signal is not present at all, video LEDs blink.

#### 4.1.2. Audio Input LEDs



- OFF:** The audio source is not selected.
- BLINKING:** The audio source is selected but no signal is detected, regardless of the output mode (e.g. DVI EDID is emulated on the port with HDMI signal).
- ON (with short pause):** Audio source is selected, the audio is embedded to the output video stream.
- ON (continuously):** Audio source is selected, the port is active but audio is not embedded in the video stream (e.g. the output mode is DVI).

#### 4.1.3. HDCP LED

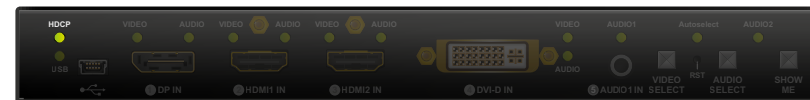

- OFF:** Video output signal is not encrypted with HDCP.
- ON:** Video output signal is encrypted with HDCP.

#### 4.1.4. USB LED



##### HDMI-3D-OPT-TX210A

- OFF:** USB is disconnected or there is no USB data transfer over the port.
- BLINKING (green):** USB connection is established between the transmitter and the computer.

##### HDMI-3D-OPT-TX210RAK / SW4-OPT-TX240RAK

- OFF:** USB is disconnected or there is no USB data transfer over the port.
- ON (green):** USB KVM: composite mode is active.
- ON (yellow):** USB KVM: transparent mode is active.

#### 4.1.5. Autoselect LED



- OFF:** Autoselect function is disabled.
- BLINKING:** Autoselect function is enabled, searching for signal (the video input LEDs are also blinking).
- ON:** Autoselect function is enabled, the active video signal is found (the selected video input's LED is also ON).

### 4.2. Front Panel Buttons - Transmitter

#### 4.2.1. Video Select Button



Only for SW4-OPT-TX240RAK model: desired video input can be selected by the **Video Select** button from the front panel. The selection order of the inputs is the following:

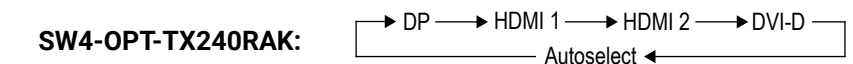

### 4.2.2. Audio Select Button



Desired audio input can be selected by the **Audio Select** button from the front panel. The selection order of the inputs depends on the model as follows:

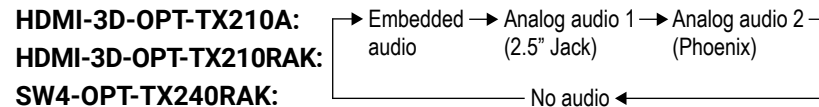

### 4.2.3. Programmable Show Me Button



Action or an operation can be assigned to the Show Me button. “Show Me button pressed” is a condition that can be selected in the Event Manager. See more details in the [Event Manager](#) section.

## 4.3. Special Functions - Transmitter

### 4.3.1. Enable DHCP (Dynamic) IP Address

**INFO:** This function is available for the SW4-OPT-TX240RAK model only.



The device has a static IP address as a factory default setting. If this setting does not fit to the circumstances during install or usage, DHCP can be enabled from the front panel:

- Step 1.** Make sure the device is powered on and operational.
- Step 2.** Press and keep pressed the **Show Me** button for 5 seconds.
- Step 3.** After 5 seconds front panel LEDs start blinking; release the button and press it 3 times again quickly (within 3 seconds).
- Step 4.** The LEDs get dark, DHCP gets enabled.

### 4.3.2. Reset to Factory Default Settings



To restore factory default values, do the following steps:

- Step 1.** Make sure the device is powered on and operational.
- Step 2.** Press and keep pressed the **Show Me** button for 10 seconds. After 5 seconds front panel LEDs start blinking but keep on pressing the button.
- Step 3.** After 10 seconds the LEDs start blinking faster; release the button and press it 3 times again quickly (within 3 seconds).
- Step 4.** The LEDs get dark, the device restores the factory default settings and reboots.

Factory default settings are listed in the [Factory Default Settings](#) section.

### 4.3.3. Control Lock

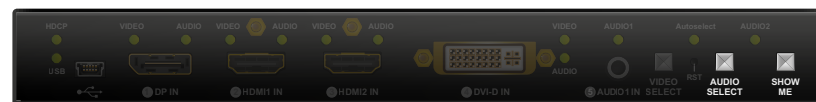

Press the **Audio Select** and **Show Me** buttons **together** (within 100 ms) to disable/enable front panel buttons; front panel LEDs blink 4 times when locking/unlocking. If the control lock is enabled and a button is pressed, front panel LEDs blink 3 times quickly.

### 4.3.4. Resetting the Device

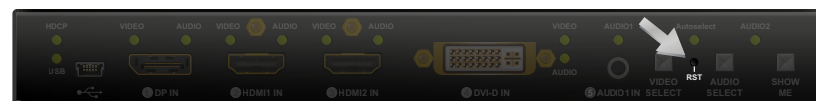

In few cases (after firmware upgrade, etc) you may need to reset the device. Pushing the reset button results the same as you disconnect and reconnect the power adaptor to the transmitter. To resetting the device follow the steps:

- Step 1.** Push the button with a thin object for a second.
- Step 2.** Wait until the device reboots. You can use the transmitter when the LIVE LED is blinking slowly again.

**ATTENTION!** Resetting the device does not reset the settings to factory defaults. To reset factory default settings see previous section.

### 4.3.5. Entering Firmware Upgrade Mode



It may happen that the firmware upgrade process is not successful and the device cannot be switched to bootload mode automatically. In this case, the device can be forced into firmware upgrade mode as follows:

- Step 1.** Make sure the transmitter is powered off.
- Step 2.** Press and keep pressed the **Show Me** button.
- Step 3.** Power on the transmitter while the **Show Me** button is being pressed. If the device is switched to firmware upgrade mode the LIVE LED is blinking quickly (less than 500 ms duty cycle). The other LEDs are off.

The procedure of firmware upgrade can be found in the [Firmware Upgrade](#) chapter.

## 4.4. Rear Panel Status LEDs - Transmitter

### 4.4.1. LIVE LED

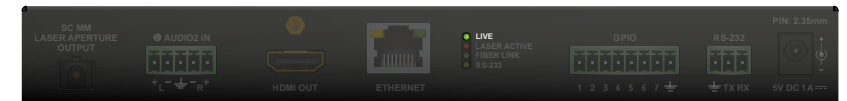

- ON (yellow):** The device is powered but not operational.
- BLINKING (green):** The device is powered and operational.
- BLINKING (red):** Alert is detected.
- BLINKING (yellow):** Firmware upgrade mode, device is in bootload mode.
- OFF:** The device is not powered.

### 4.4.2. LASER ACTIVE LED



- ON (red):** Laser transmission is enabled.



#### 4.4.3. FIBER LINK LED

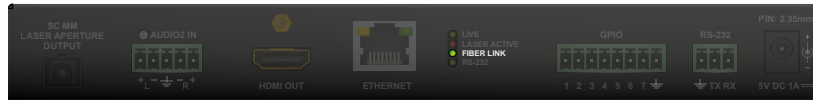

- ON:** Fiber link is established.
- OFF:** No fiber link between the transmitter and the receiver.

#### 4.4.4. RS-232 LED

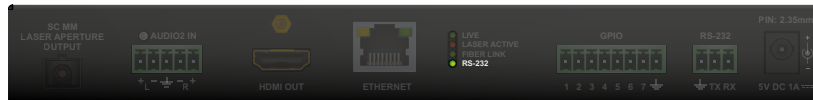

- ON:** RS-232 ports (local and link) are in [Control Mode](#).
- BLINKING:** [Command Injection Mode](#) is active. (only in case of SW4-OPT-TX240RAK model)
- OFF:** RS-232 ports (local and link) are in [Pass-through Mode](#).

**INFO:** Only HDMI-3D-OPT-TX210RAK and SW4-OPT-TX240RAK models has RS-232 LED.

### 4.5. Front Panel LEDs - Receiver

#### 4.5.1. POWER LED



- ON:** The receiver is powered.

#### 4.5.2. Status LEDs



#### HDCP

- ON:** Video input signal is encrypted with HDCP.
- OFF:** Video input signal is not encrypted with HDCP.

#### HDMI

- ON:** The input and output signal type is HDMI.
- BLINKING:** The input signal type is HDMI but the output signal is DVI.
- OFF:** The input signal type is DVI.

#### SIGNAL

- ON:** A valid video clock signal is present on the fiber input port of the receiver.

#### LASER

- ON:** The laser signal of a connected transmitter is detected on the fiber input port.

#### HOTPLUG

- ON:** A powered sink device is connected to the HDMI OUT port and sends hotplug signal.

#### EMULATE

- ON:** Composite port is active in the USB KVM crosspoint.
- OFF:** No port is active or transprens port is active in the USB KVM crosspoint.

#### USB LINK

- ON:** USB KVM signal is detected on the fiber input port.

#### FIBER LINK

- ON:** A powered transmitter is connected to the receiver and they can communicate over the fiber optical cable.

### 4.6. Special Functions - Receiver

#### 4.6.1. Reset to Factory Default Settings



To restore factory default values, do the following steps:

- Step 1.** Make sure the device is powered on and operational.
- Step 2.** Press and keep pressed the **Show Me** button for 10 seconds. After 5 seconds front panel LEDs start blinking but keep on pressing the button.
- Step 3.** After 10 seconds the LEDs start blinking faster; release the button and press it 3 times again quickly (within 3 seconds).
- Step 4.** The LEDs get dark, the device restores the factory default settings and reboots.

Factory default settings are listed in the [Factory Default Settings](#) section.

#### 4.6.2. Entering Firmware Upgrade Mode



It may happen that the firmware upgrade process is not successful and the device cannot be switched to bootload mode automatically. In this case, the device can be forced into firmware upgrade mode as follows:

- Step 1.** Make sure the receiver is powered off.
- Step 2.** Press and keep pressed the **Function** button.
- Step 3.** Power on the receiver. If the device is switched to bootload mode the Status LEDs are blinking quickly (less than 500 ms duty cycle).

The procedure of firmware upgrade can be found in the [Firmware Upgrade](#) chapter.

## 4.7. Software Control Modes

User has more possibilities to control the device besides the front panel buttons. The following list contains the software control modes:

- **Lightware Device Controller (LDC)** - you can connect to the device via our control software using Ethernet or RS-232 interface and control or configure the device as you wish. For the details see the [Software Control - Lightware Device Controller](#) chapter.
- **LW2 protocol commands**: you can configure the device by using the reduced command set of LW2 protocol. For more details see the [LW2 Programmer's Reference](#) chapter.
- **LW3 protocol commands**: you can configure the device by using the full-range command set of LW3 protocol. For more details see the [LW3 Programmer's Reference](#) chapter.

# 5

## Software Control - Lightware Device Controller

The device can be controlled by a computer through USB, RS-232, and Ethernet (only for SW4-OPT-TX240RAK model) interfaces by the Lightware Device Controller (LDC). The software can be installed on a Windows PC or Mac OS X. The application and the User's Manual can be downloaded from [www.lightware.com](http://www.lightware.com).

- ▶ INSTALL AND UPGRADE
- ▶ ESTABLISHING THE CONNECTION
- ▶ CROSSPOINT / PORT CONTROL MENU
- ▶ PORT PROPERTIES WINDOWS
- ▶ DIAGNOSTIC TOOLS
- ▶ USB KVM
- ▶ EDID MENU
- ▶ CONTROL / DEVICE CONTROL MENU
- ▶ EVENT MANAGER
- ▶ SETTINGS MENU
- ▶ CONFIGURATION CLONING (BACKUP TAB)
- ▶ ADVANCED VIEW WINDOW

### 5.1. Install and Upgrade

**INFO:** After the installation, the Windows and the Mac application has the same look and functionality. This type of the installer is equal with the Normal install in case of Windows and results an updateable version with the same attributes.

#### Installation for Windows OS

Run the installer. If the User Account Control drops a pop-up message click **Yes**.

During the installation you will be prompted to select the type of the installation: **normal** and the **snapshot** install:

Normal install	Snapshot install
Available for Windows and Mac OS X	Available for Windows
The installer can update only this instance	Cannot be updated
Only one updateable instance can exist for all users	More than one different version can be installed for all users

#### Comparison of installation types

**ATTENTION!** Using the Normal install as the default choice is highly recommended.

#### Installation for Mac OS X

Mount the DMG file with double clicking on it and drag the LDC icon over the Applications icon to copy the program into the Applications folder. If you want to copy the LDC into another location just drag the icon over the desired folder.

#### Upgrading of LDC

**Step 1.** Run the application.

The **Device Discovery** window appears automatically and the program checks the available updates on Lightware's website and opens the update window if the LDC found updates.

The current and the update version number can be seen at the top of the window and they are shown in this window even with the snapshot install.

The **Update** window can also be opened by clicking the **About** icon  and the **Update** button.

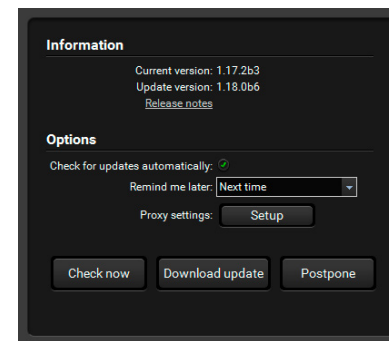

**Step 2.** Set the desired update setting in the **Options** section.

- If you do not want to check for the updates automatically, uncheck the **circle**, which contains the green tick.
- If you want to postpone the update, a reminder can be set with different delays from the **drop down list**.
- If the proxy settings traverse the update process, set the proper values then click the **OK** button.

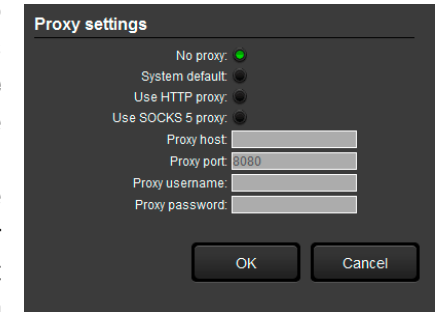

**Step 3.** Click the **Download update** button to start the upgrading.

The updates can be checked manually by clicking the **Check now** button.

### 5.2. Establishing the Connection

**Step 1.** Connect the device to a computer via USB, RS-232, or Ethernet.

**Step 2.** Run the controller software; device discovery window appears automatically.

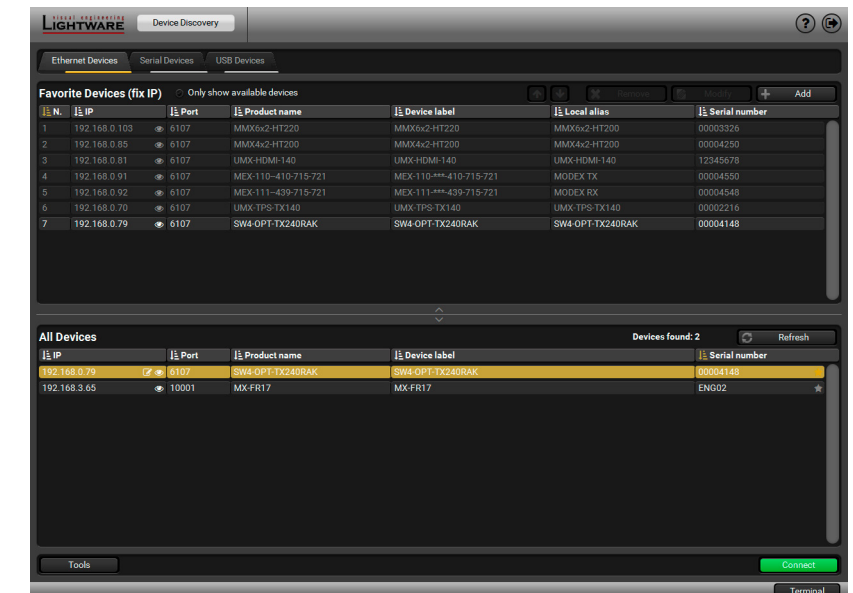

Device discovery window in LDC

**Change IP Address** 

To modify IP address settings quickly it is not necessary to enter the device's settings/network menu, you can set them by clicking the pencil icon beside the IP address.

You can see the new settings only in this window.

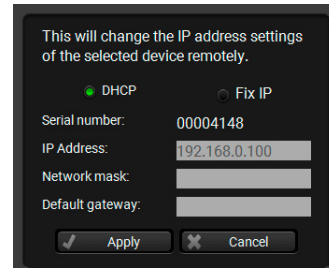

**Step 3.** Select the unit from the discovered Ethernet devices or under Serial devices; when the device is connected through RS-232 click on the **Query** button next to the desired serial port to display the device's name and serial number. Double click on the transmitter or select the device and click on the **Connect** button.

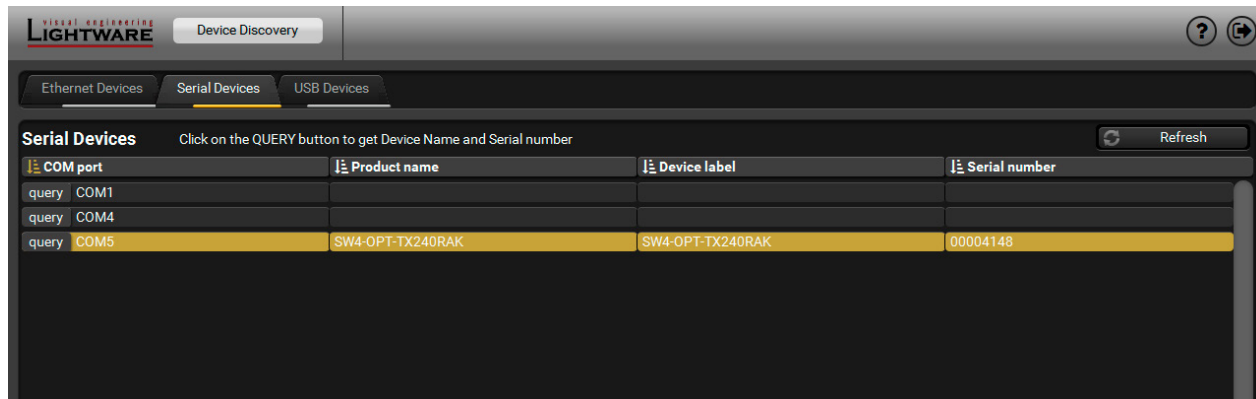

**Serial devices tab in LDC**

**ATTENTION!** Before the device is connected via the local RS-232 port, make sure that **Control mode** and **LW3 protocol** are set on the serial port.

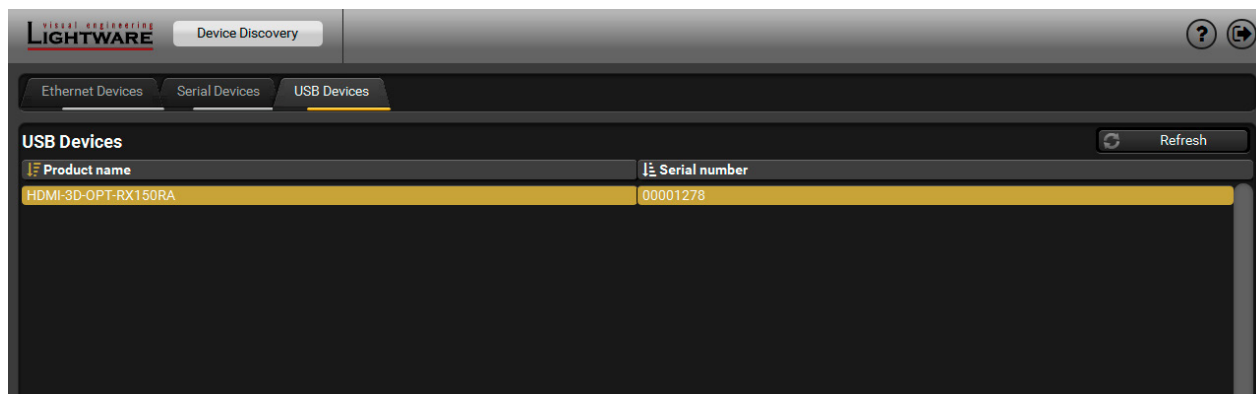

**USB tab in LDC**

**5.3. Crosspoint / Port Control Menu**



- 1 **Main menu** The available menu items are displayed. The active one is showed with dark grey background color.
- 2 **Information ribbon** The label shows the device label which can be edited in the Settings menu - **Status** tab. Device discovery window can be displayed by clicking on this ribbon.
- 3 **Video input ports** Each tile represents a video input port. The tile below the port shows the current crosspoint setting; if the port is switched to the output, the color of the tile is white, otherwise grey.
- 4 **Audio input ports** Each tile represents an audio input port. The tile below the port shows current crosspoint setting; if the port is switched to the output, the color of the tile is white, otherwise grey. Dark grey means the audio port is not allowed to embed in the current video input port.
- 5 **Advanced view** Displaying the **Advanced View Window**, showing the Terminal window and the LW3 protocol tree.
- 6 **Audio output ports** The audio output of the optical link and local HDMI out ports. Clicking on the tile opens the **Digital Audio Outputs** port properties window.
- 7 **Video output ports** The video output of the optical link and local HDMI out ports. Clicking on the tile opens the **Video Outputs** port properties window.

### Port Tiles

The colors of the port tiles and the displayed icons represent different states and information:

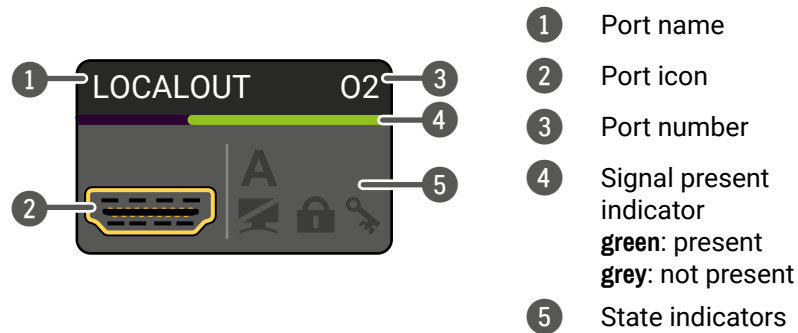

- 1 Port name
- 2 Port icon
- 3 Port number
- 4 Signal present indicator  
green: present  
grey: not present
- 5 State indicators

### State Indicators

Following icons display different states of the port/signal:

Icon	Icon is grey	Icon is black	Icon is green
	Signal is not encrypted with HDCP	Signal is encrypted with HDCP	-
	Port is unmuted	Port is muted	-
	Port is unlocked	Port is locked	-
	Autoselect is disabled	-	Autoselect is enabled

## 5.4. Port Properties Windows

Clicking on the port tile opens the Port properties window. This section shows the available settings and status information by port types.

### 5.4.1. Video Inputs

Clicking on the HDMI, DisplayPort, or DVI-D video input port icon results opening the Port properties window. The most important information and settings are available from the panel.

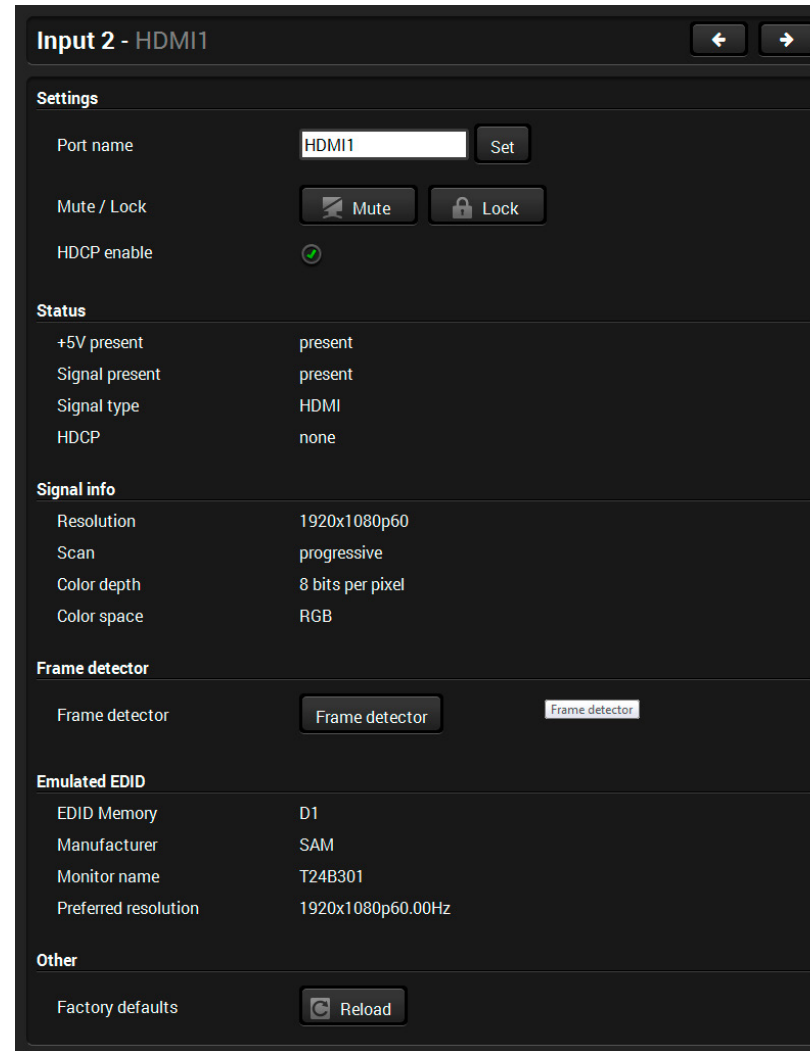

Port properties window of the HDMI video input

### Available settings:

- Mute/unmute the port;
- Lock/unlock the port;
- HDCP setting (enable / disable);
- [Frame Detector](#);
- Reloading factory default settings for the selected port.

### 5.4.2. Digital Audio Inputs

Clicking on the HDMI, DisplayPort, or DVI-D audio input port icon results opening the Port properties window. The most important information and settings are available from the panel.

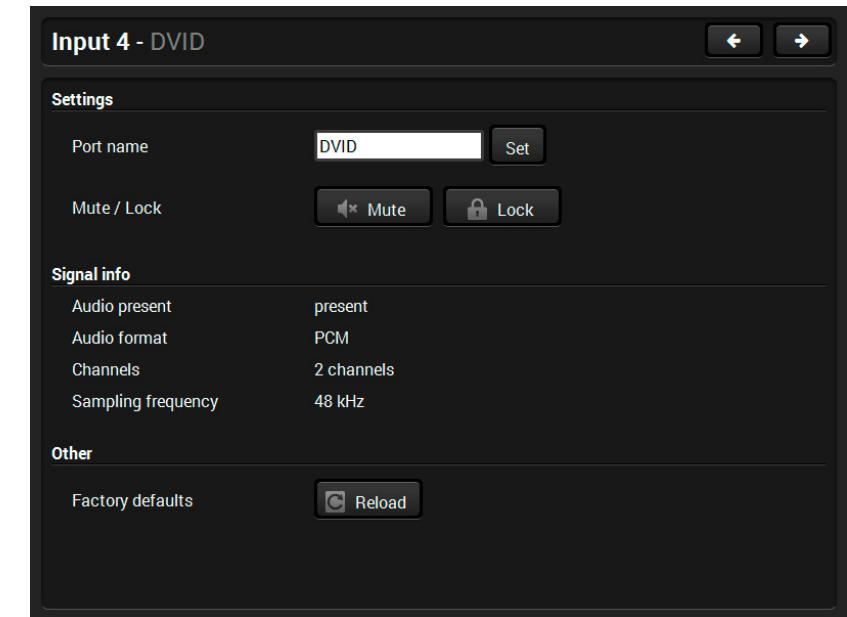

Port properties window of the DVI-D audio input

Certain parameters of the embedded audio input signal can be set as follows:

- Mute/unmute the port;
- Lock/unlock the port;
- Reloading factory default settings for the selected port.

### 5.4.3. Analog Audio Inputs

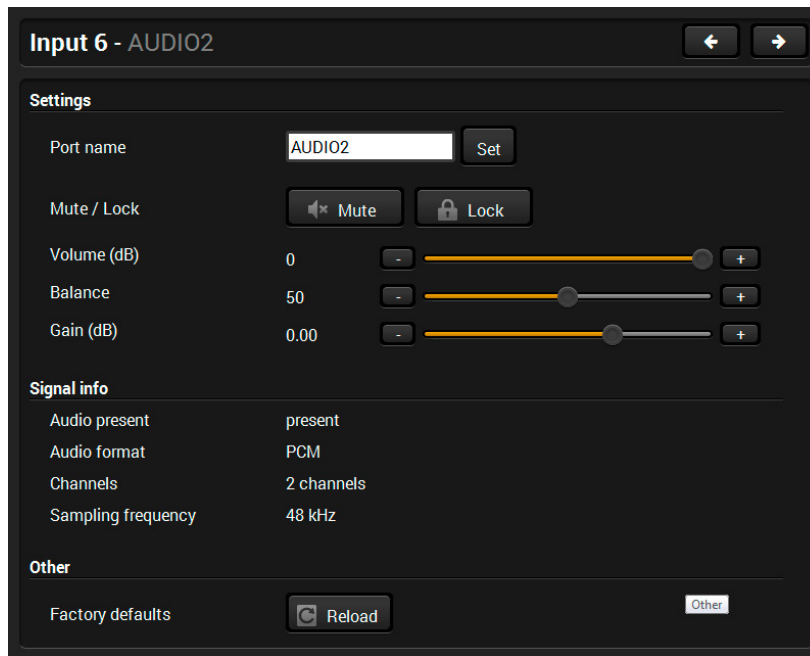

**Port properties window of the Analog Audio 2 (Phoenix) input**

Certain parameters of the analog audio input signal can be set as follows:

- Mute/unmute the port;
- Lock/unlock the port;
- Volume: from 0 dB to -95.62 dB, in step 0.375 dB (default is 0 dB);
- Balance: from 0 to 100, in step 1 (default is 50 = center);
- Gain: -12 to 6 dB, in step 3 dB (default is 0 dB);
- Reloading factory default settings for the selected port.

### 5.4.4. Video Outputs

Click on the output port to display its properties. The most important information and settings are available from the panel.

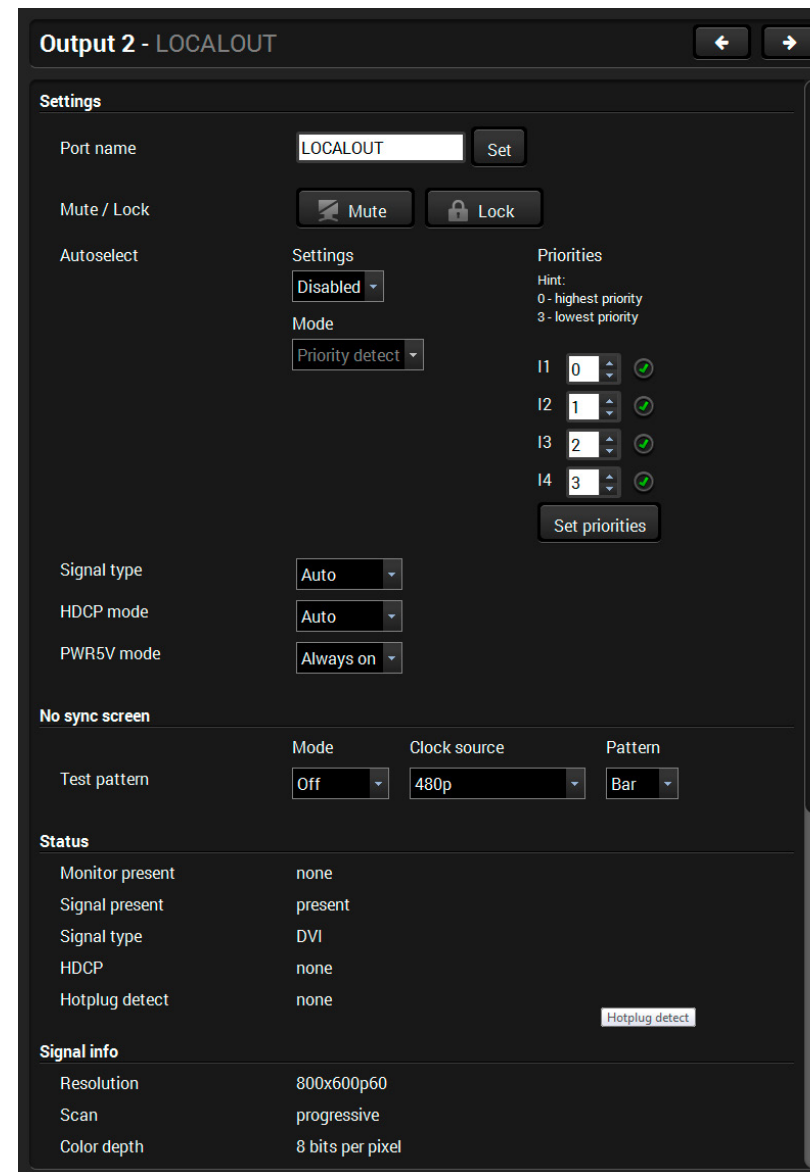

**Port properties window of the local HDMI video output**

#### Available settings:

- Mute/unmute the port;
- Lock/unlock the port;
- **Autoselect settings:** enable / disable, mode, and priorities. (See more details about the feature in [The Autoselect Feature](#) section);
- **Signal type:** Auto / DVI / HDMI - The outgoing signal format can be selected by a drop-down menu;
- **HDCP mode:** Auto / Always - The transmitter forces the source sent the signal without encryption if the content allows when Auto mode is selected;
- **Power 5V mode:** Auto / Always on / Always off - The setting lets the source and the sink devices be connected – independently from the transmitted signal;
- **Laser enable:**
  - **On:** high-speed (AV signal) and low-speed (serial, USB) communications are transmitted.
  - **Standby:** only low-speed (serial, USB) communication is transmitted.
- **No sync screen:** configuration settings of the test pattern. See more details in the [No Sync Screen \(Test Pattern\)](#) section.
- [Frame Detector](#);
- Reloading factory default settings for the selected port.

### 5.4.5. Digital Audio Outputs

Click on the output port to display its properties. The most important information and settings are available from the panel.

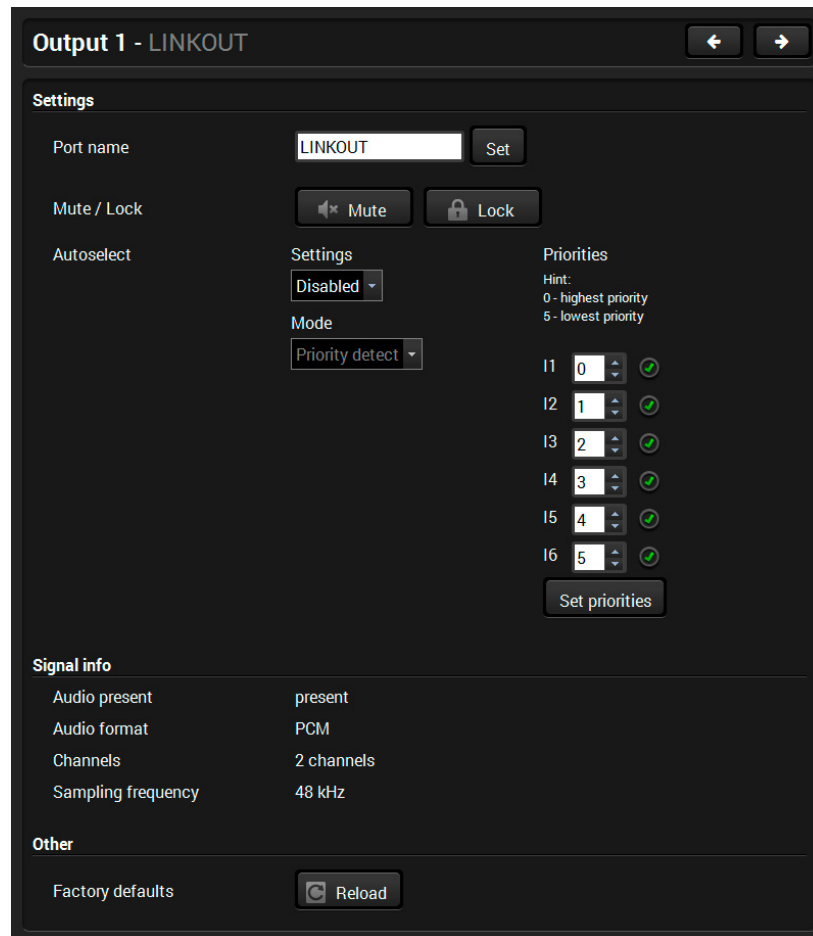

**Port properties window of the optical link audio output**

#### Available settings:

- Mute/unmute the port;
- Lock/unlock the port;
- **Autoselect settings:** enable / disable, mode, and priorities. (See more details about the feature in [The Autoselect Feature](#) section);
- Reloading factory default settings for the selected port.

### 5.4.6. Analog Audio Output

Click on the output port to display its properties. The most important information and settings are available from the panel.

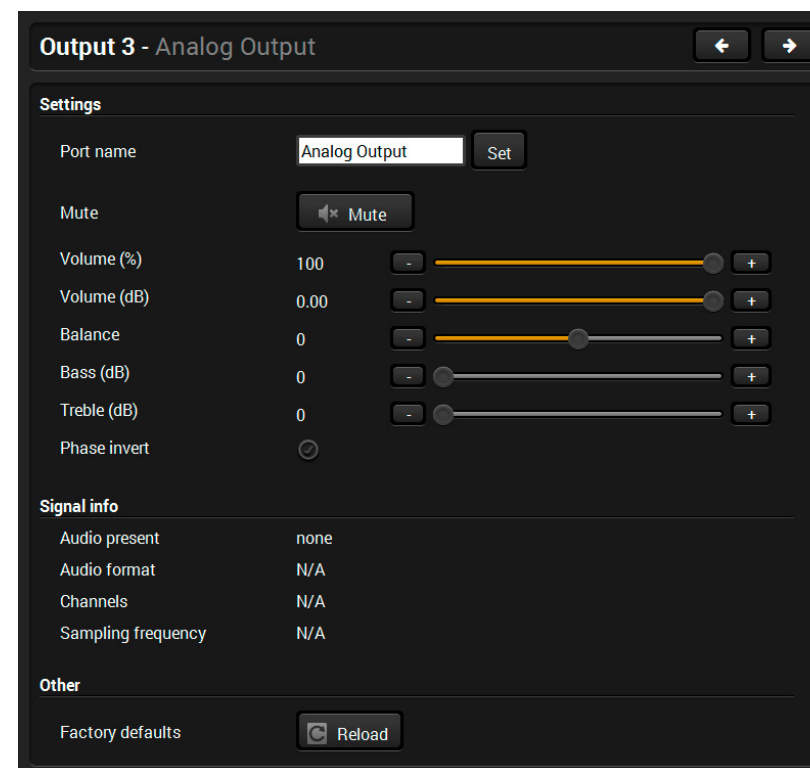

**Port properties window of the analog audio output**

Certain parameters of the analog audio output signal can be set as follows:

- Mute/unmute the port;
- Lock/unlock the port;
- Volume (%): from 100% to 0%, in step 1% (default is 100%);
- Volume (dB): from 0 dB to -63 dB, in step 1 dB (default is 0 dB);
- Balance: from -100 to 100, in step 1 (default is 0 = center);
- Bass (dB): from 0 dB to 24 dB, in step 2 dB (default is 0 dB);
- Treble (dB): from 0 dB to 6 dB, in step 2 dB (default is 0 dB);
- Phase invert: enable / disable;
- Reloading factory default settings for the selected port.

## 5.5. Diagnostic Tools

### 5.5.1. Frame Detector

The ports can show detailed information about the signal like full size and active video resolution. This feature is a good troubleshooter if compatibility problems occur during system installation. To access this function, open the port properties window and click on **Frame detector** button.

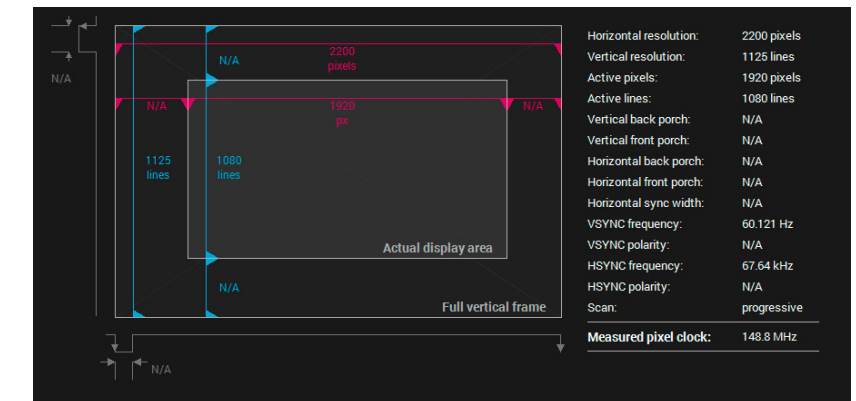

**Frame detector window**

Lightware's Frame Detector function works like a signal analyzer and makes possible to determine the exact video format that is present on the port, thus helps to identify many problems. E.g. actual timing parameters may differ from the expected and this may cause some displays to drop the picture.

Frame Detector measures detailed timings on the video signals just like a built-in oscilloscope, but it is much more easy to use. Actual display area shows the active video size (light grey). Dark grey area of the full frame is the blanking interval which can contain the info frames and embedded audio data for HDMI signals. Shown values are measured actually on the signal and not retrieved only from the HDMI info frames.

### 5.5.2. No Sync Screen (Test Pattern)

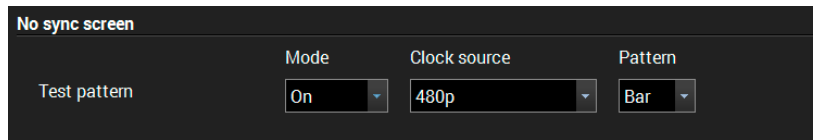

*Test pattern options in the port properties window of the optical output*

The No sync screen feature generates an image which can be displayed when there is no incoming signal on the port. The following settings can be set for the Test Pattern function:

#### Mode

- **On:** the video output port always transmits the test pattern.
- **No signal:** the video output port transmits the test pattern if there is no incoming signal on the selected input port.
- **Off:** the test pattern function is disabled, the video output port transmits the video signal of the selected input port.

#### Clock Source

- 480p
- 576p
- Original video signal

#### Pattern

- Red
- Green
- Blue
- Black
- White
- Ramp
- Chess
- Bar
- Cycle

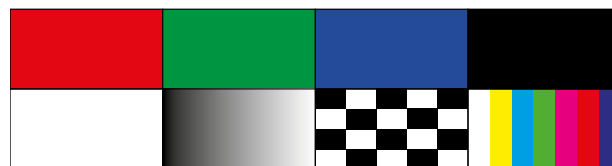

### 5.6. USB KVM

#### 5.6.1. USB KVM in the Receiver



*USB KVM layer in the Receiver*

Two USB modes can be set on the USB KVM tab: **Transparent** and **Composite**. For the detailed information about these modes see the [USB KVM Function](#) section.

You can use the crosspoint selectors for switching between the USB modes. The factory default settings is the **Autoselect** (indicated with green A on the output side) which means the extender recognizes the attached USB HID devices and sets the mode automatically. In this case the A icon is highlighted in green on the output ports.

You can recall the default crosspoint settings by clicking on the **Reset XP** button.

#### Port Properties

Click on the output port to open the port properties window. The most important status information is displayed on the panel and the **Autoselect mode** and the **priorities** can be set.

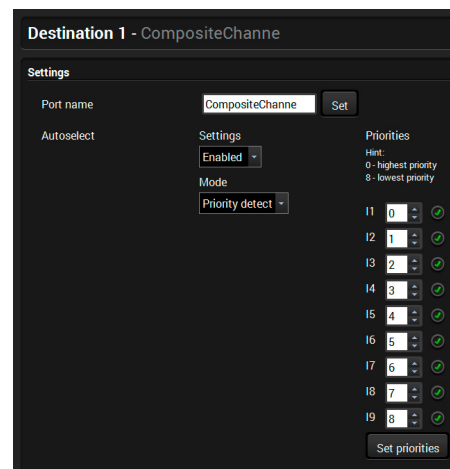

#### Using of USB HUBs



*USB KVM layer in case of a connected 4-port USB HUB*

The receiver built with two physical USB ports but the users are able to extend the number of the handled HID-compliant devices using USB HUBs. The extender can handle up to 5 USB ports.

**ATTENTION!** The transparent channels can handle one USB device only, the composite channel can handle more HID-compliant devices.

#### 5.6.2. USB KVM in the Transmitter

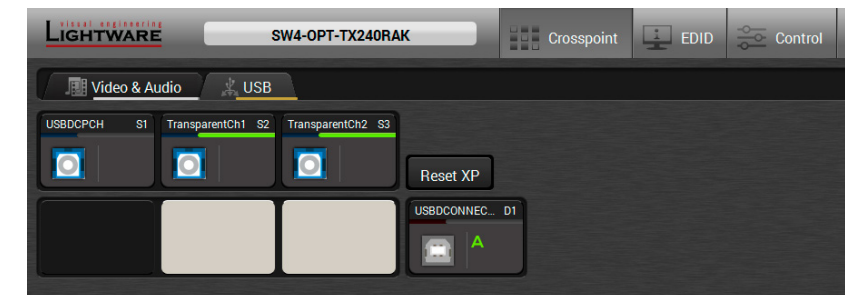

*USB KVM layer in the Transmitter*

The crosspoint status can be set on the USB KVM tab. USB mode can be **Transparent** or **Composite**, see the details in the [USB KVM Function](#) section. The green highlights indicate the active USB mode. The USB KVM function works only if crosspoint is set to the active USB channel.

You can recall the default crosspoint settings by clicking on the **Reset XP** button.

**INFO:** Crosspoint switching in the transmitter between the composite and transparent channels will be successful only in the case of presence of active USB devices on the receiver side.



## 5.7. EDID Menu

Advanced EDID Management can be accessed by selecting the EDID menu. There are two panels: left one contains Source EDIDs, right one contains Destination places where the EDIDs can be emulated or copied.

The screenshot shows the EDID menu interface with the following components:

- Source Panel (Left):** A table with columns: Mem..., Manu..., Resolution, Audio, Monitor Name. It lists 22 EDID entries (F1-F22).
- Emulated Panel (Right):** A table with columns: Mem..., Manu..., Resolution, Audio, Monitor Name. It lists 14 EDID entries (U1-U14).
- Control Buttons:** Export, Import, Info, Edit, Create, Transfer (right arrow), Delete selected, Select all, Select none.
- Advanced view:** A button at the bottom right of the interface.

EDID menu

### Control Buttons



Exporting an EDID (save to a file)



Importing an EDID (load from a file)



Display EDID Summary window



Opening Advanced EDID Editor with the selected EDID



Opening Easy EDID Creator



Transfer button: executing EDID emulation or copying



Deleting EDID (from User memory)



Selecting all memory places in the right panel



Selecting none of the memory places in the right panel

### 5.7.1. EDID Operations

#### Changing Emulated EDID

**Step 1.** Choose the desired **EDID list** on the source panel and select an **EDID**.

**Step 2.** Press the **Emulated** button on the top of the Destination panel.

**Step 3.** Select the desired **port** on the right panel (one or more ports can be selected); the EDID(s) will be highlighted with a yellow cursor.

**Step 4.** Press the **Transfer** button to change the emulated EDID.

#### Learning an EDID

The process is the same as changing the emulated EDID; the only difference is the Destination panel: press the **User** button. Thus, one or more EDIDs can be copied into the user memory either from the factory memory or from a connected sink (Dynamic).

#### Exporting an EDID

**ATTENTION!** This function is working on Windows and Mac OS X operating systems and under Firefox or Chrome web browsers only.

Source EDID can be downloaded as a file (\*.bin, \*.dat or \*.edid) to the computer.

**Step 1.** Select the desired **EDID** from the Source panel (line will be highlighted with yellow).

**Step 2.** Press the **Export** button to open the dialog box and save the file to the computer.

#### Importing an EDID

Previously saved EDID (\*.bin, \*.dat or \*.edid file) can be uploaded to the user memory:

**Step 1.** Press the **User** button on the top of the Source panel and select a **memory slot**.

**Step 2.** Press the **Import** button below the Source panel.

**Step 3.** Browse the file in the opening window then press the **Open** button. Browsed EDID is imported into the selected User memory.

**ATTENTION!** The imported EDID overwrites the selected memory place even if it is not empty.

#### Deleting EDID(s)

The EDID(s) from User memory can be deleted as follows:

**Step 1.** Press **User** button on the top of the Destination panel.

**Step 2.** Select the desired **memory slot(s)**; one or more can be selected (“Select All” and “Select None” buttons can be used). The EDID(s) will be highlighted with yellow.

**Step 3.** Press the **Delete selected** button to delete the EDID(s).

### 5.7.2. EDID Summary Window

Select an EDID from Source panel and press **Info** button to display EDID summary.



**General**

EDID version:	1
EDID revision:	3
Manufacturer ID:	SAM (Samsung Electric Company)
Product ID:	8E09
Monitor serial number:	Not present
Year of manufacture:	2012
Week of manufacture:	9
Signal interface:	Digital
Separate Sync H&V:	-
Composite sync on H:	-
Sync on green:	-
Serration on VS:	-
Color depth:	Undefined
Interface standard:	Not defined
Color spaces:	RGB 4:4:4 & YCrCb 4:4:4
Aspect ratio:	0.56
Display size:	52 cm X 29 cm

*EDID summary window*

### 5.7.3. Editing an EDID

Select an EDID from Source panel and press Edit button to display Advanced EDID Editor window. The editor can read and write all descriptors, which are defined in the standards, including the additional CEA extensions. Any EDID from the device's memory or a saved EDID file can be loaded into the editor. The software resolves the raw EDID and displays it as readable information to the user. All descriptors can be edited, and saved in an EDID file, or uploaded to the User memory. For more details about EDID Editor please visit our website ([www.lightware.com](http://www.lightware.com)) and download EDID Editor user's manual.



**Basic EDID**

- Vendor / Product Information
- Display Parameters
- Power Management and Features
- Gamma / Color and Established Timings
- Standard Timings
- Preferred Timing Mode
- 2nd Descriptor Field
- 3rd Descriptor Field
- 4th Descriptor Field
- CEA Extension
- General
- Video Data
- Audio Data
- Speaker Allocation Data
- HDMI
- Colorimetry
- Detailed Timing Descriptor #1
- Detailed Timing Descriptor #2
- Detailed Timing Descriptor #3
- Detailed Timing Descriptor #4
- Detailed Timing Descriptor #5
- Detailed Timing Descriptor #6
- Save EDID

**EDID Byte Editor**

	0	1	2	3	4	5	6	7	8	9
0	00	FF	FF	FF	FF	FF	FF	00	4C	2D
10	8E	09	00	00	00	00	09	16	01	03
20	80	34	1D	78	0A	7D	D1	A4	56	50
30	A1	28	0F	50	54	BD	EF	80	71	4F
40	81	C0	81	00	81	80	95	00	A9	C0
50	B3	00	01	01	02	3A	80	18	71	38
60	2D	40	58	2C	45	00	09	25	21	00
70	00	1E	66	21	56	AA	51	00	1E	30
80	46	8F	33	00	09	25	21	00	00	1E
90	00	00	00	FD	00	18	4B	1A	51	17
100	00	0A	20	20	20	20	20	20	00	00
110	00	FC	00	54	32	34	42	33	30	31
120	0A	20	20	20	20	20	01	6C		

*EDID Editor window*

### 5.7.4. Creating an EDID - Easy EDID Creator

Since above mentioned Advanced EDID Editor needs more complex knowledge about EDID, Lightware introduced a wizard-like interface for fast and easy EDID creation. With Easy EDID Creator it is possible to create custom EDIDs in four simple steps. By clicking on the **Create** button below Source panel, **Easy EDID Creator** is opened in a new window. For more details about EDID Editor please visit our website ([www.lightware.com](http://www.lightware.com)) and download EDID Editor user's manual.

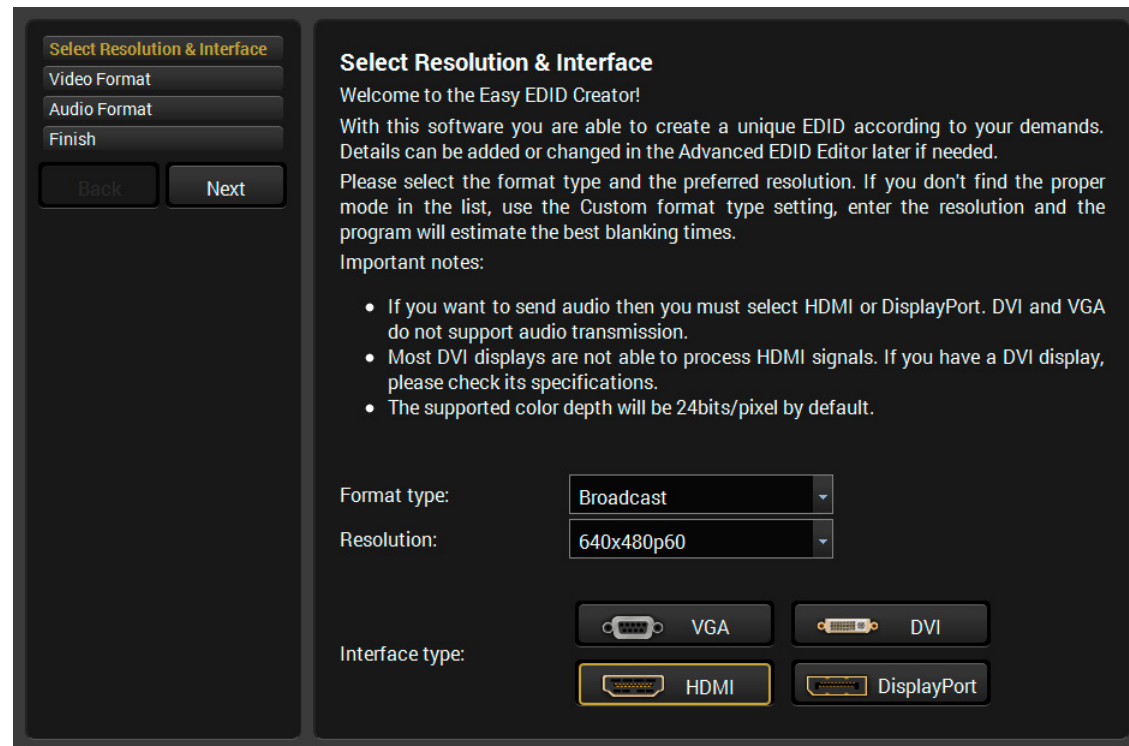

*EDID Creator window*

## 5.8. Control / Device Control Menu

### 5.8.1. RS-232

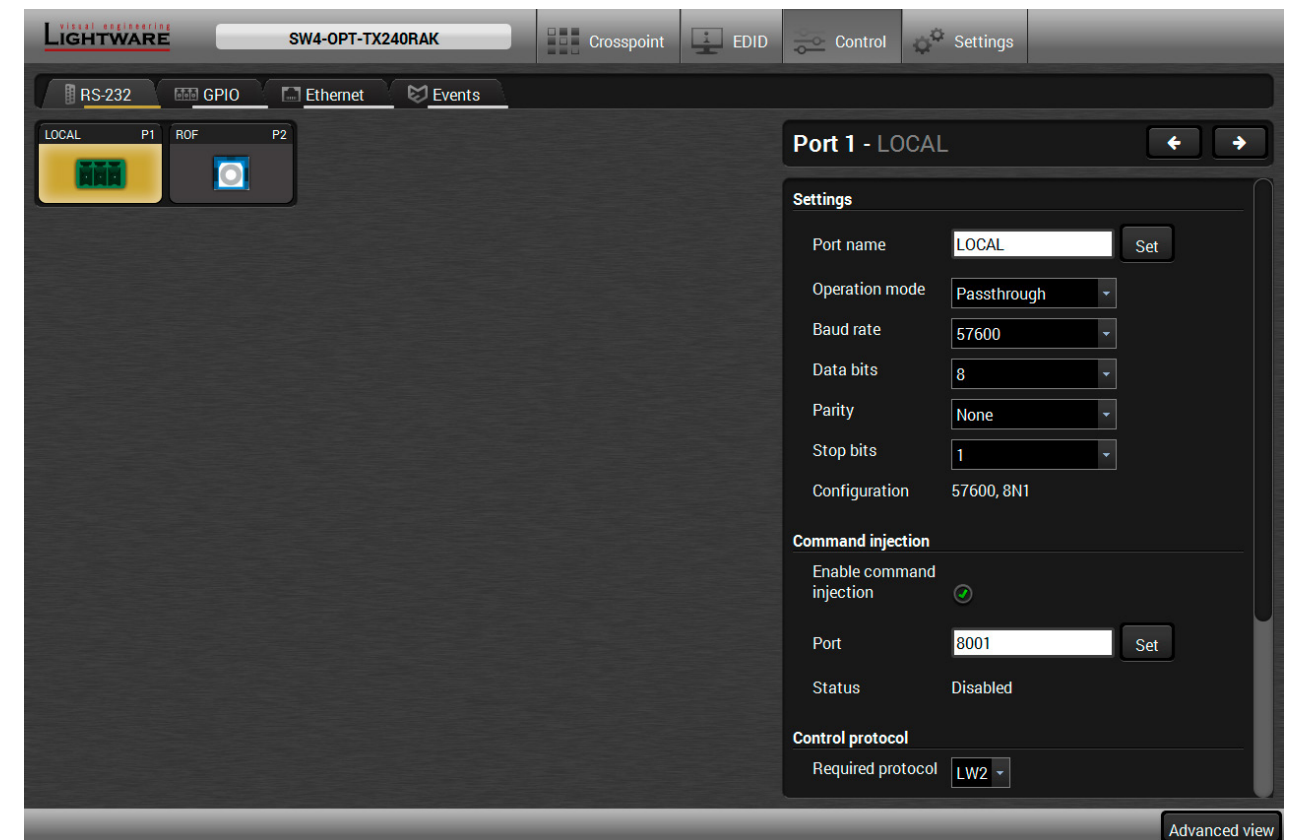

*RS-232 tab in Control menu*

The following settings and functions are available on the **local** and **optical link** RS-232 port:

- **Operation mode:** Control, Pass-through, and Command Injection (for more details about serial interface modes see the [Serial Interface](#) section);
- Baud rate: 4800, 7200, 9600, 14400, 19200, 38400, 57600, 115200;
- Data bits: 8 or 9;
- Parity: None, Odd, or Even;
- Stop bits: 1, 1.5, or 2;
- Command injection: enable or disable;
- Command injection port number;
- Control protocol: LW2 or LW3;
- Message sending via serial port;
- Reloading the [Factory Default Settings](#).

### 5.8.2. GPIO

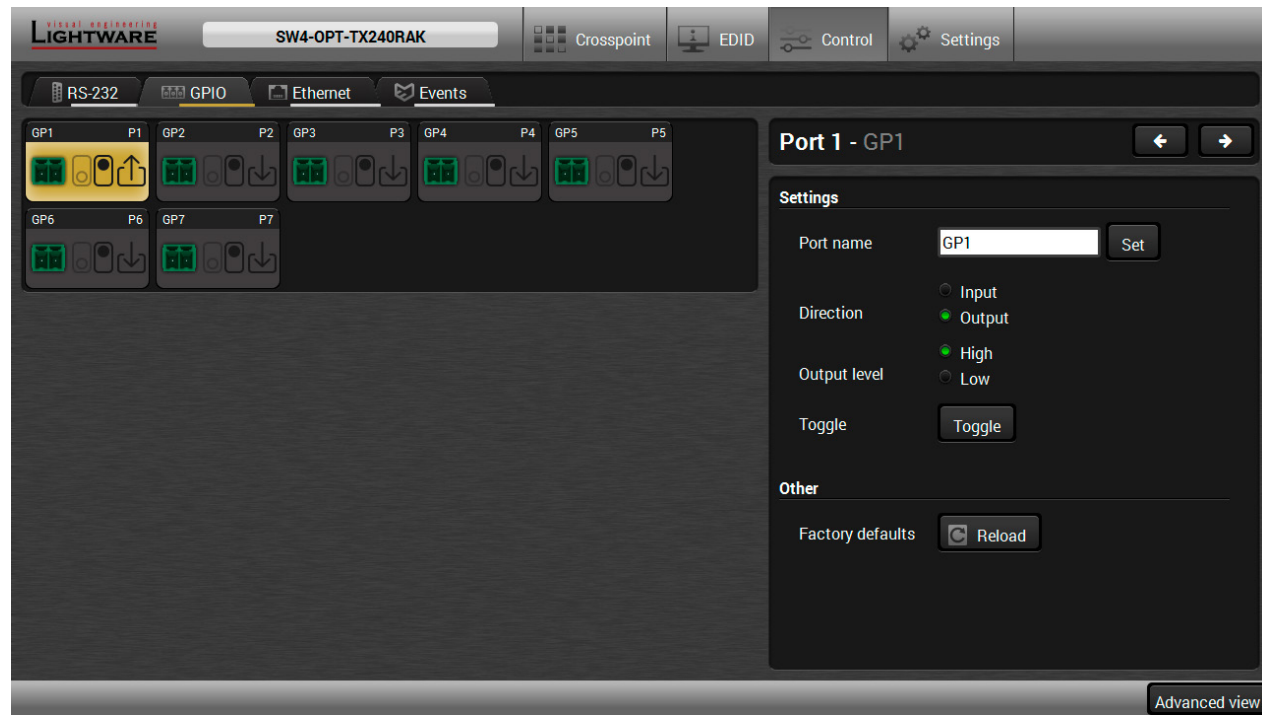

*GPIO tab in Control menu*

The GPIO port has 7 pins, which operate at TTL digital signal levels and can be controlled by LDC or protocol commands. Select a GPIO pin and under the Port settings section; the settings (pin direction and input level) are displayed on the port tiles as well:

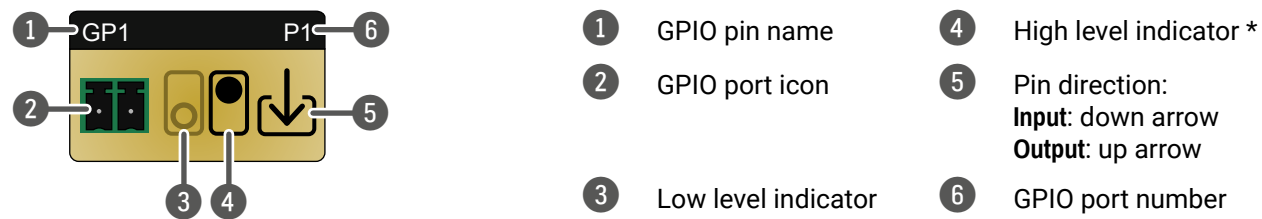

\* Highlighted with black means the current setting.

INFO: Output level can be set only in case of setting the pin direction to Output. In case of input direction the output level setting and the Toggle button is not available.

For more details about GPIO interface see the [GPIO Interface](#) section.

### 5.8.3. Ethernet

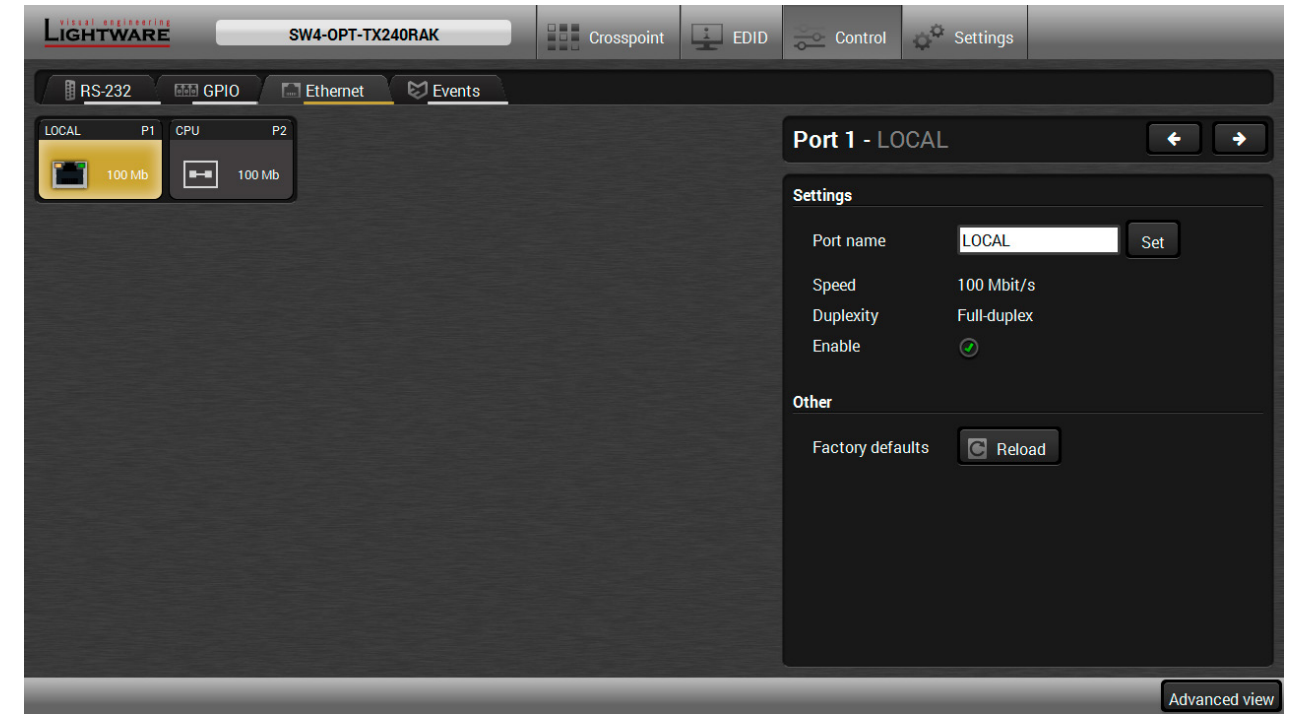

*Ethernet tab in Control menu*

Two ports are displayed in the Ethernet settings: Local and CPU. You can check the status of the Ethernet line by each ports: the speed and the duplexity of the connection.

The following settings are available for the local port:

- Enable / disable the port;
- Reloading factory defaults.

**ATTENTION!** If the Ethernet port is set to disabled, this may break the connection with the device.

INFO: CPU Ethernet port cannot be disabled.

## 5.9. Event Manager

The feature means that the device can sense changes on its ports and able to react according to the pre-defined settings. The development idea of the Event manager is based on users' feedbacks. In many cases internal events (such as signal present or HDCP active) are necessary to display but it is not easy when the device is hard to access (e.g. built under the desk). For more details and examples about Event Manager please visit our website ([www.lightware.com](http://www.lightware.com)) and download **Event Manager user's guide** in the Downloads section.



The Event manager can be configured to perform an action if a condition has been detected. E.g. the desired setup is that after a certain type of signal has been detected on I1 port, the port has to be switched to O1. The settings can be done via the LDC in the Control/Events tab, or by LW3 protocol commands. Configurable events number depends on the device what you are using actually.

Numerous new ideas and requests have been received in connection with the features and settings of the Event manager since the first release. Therefore, the user interface has been re-designed and many new functions implemented. The Event editor can be opened by pressing the **Edit** button at each Event.

There is a **grey bar** on the left of the Event panel in each line. If a condition and an action are set and the Event is enabled, the bar is displayed in **green**.

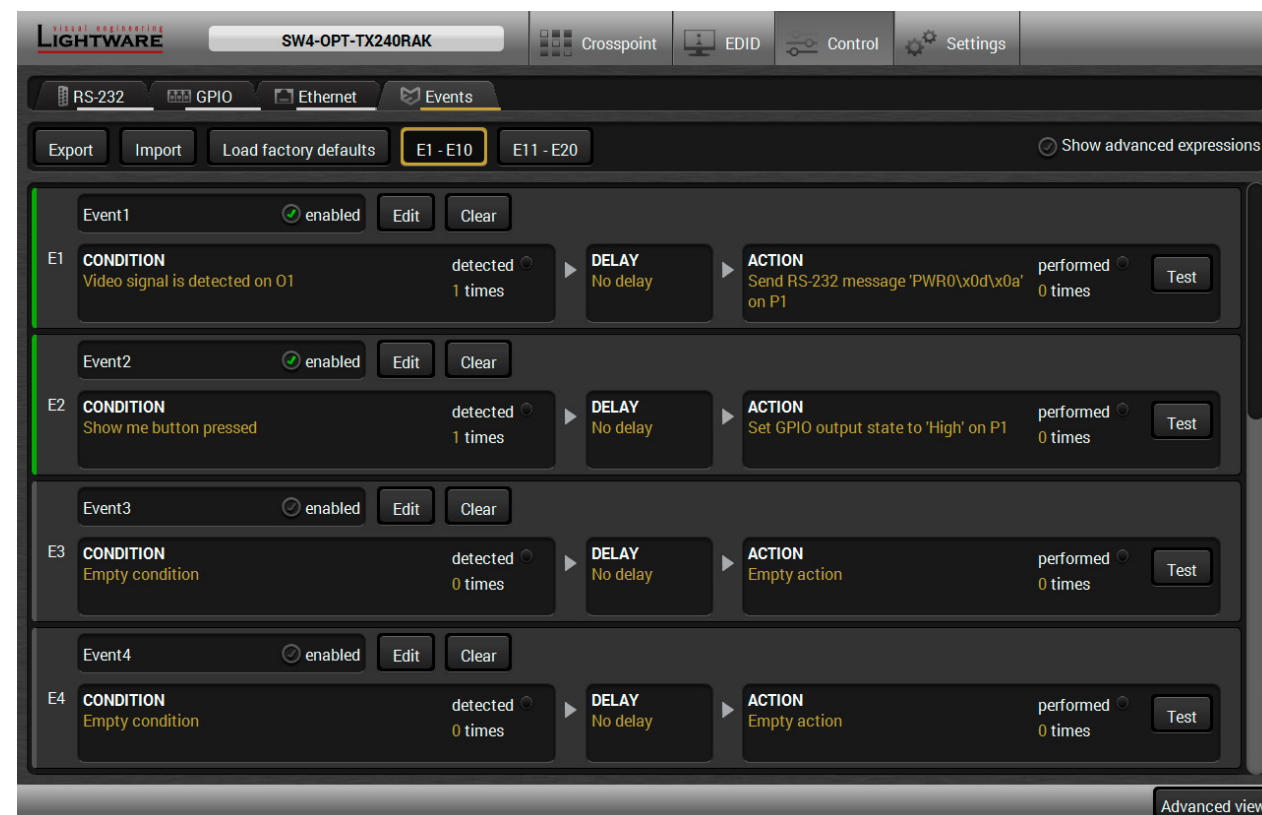

Control menu, Event Manager tab

### The Event Editor

Press the **Edit** button in the desired Event line to open the Event editor window.

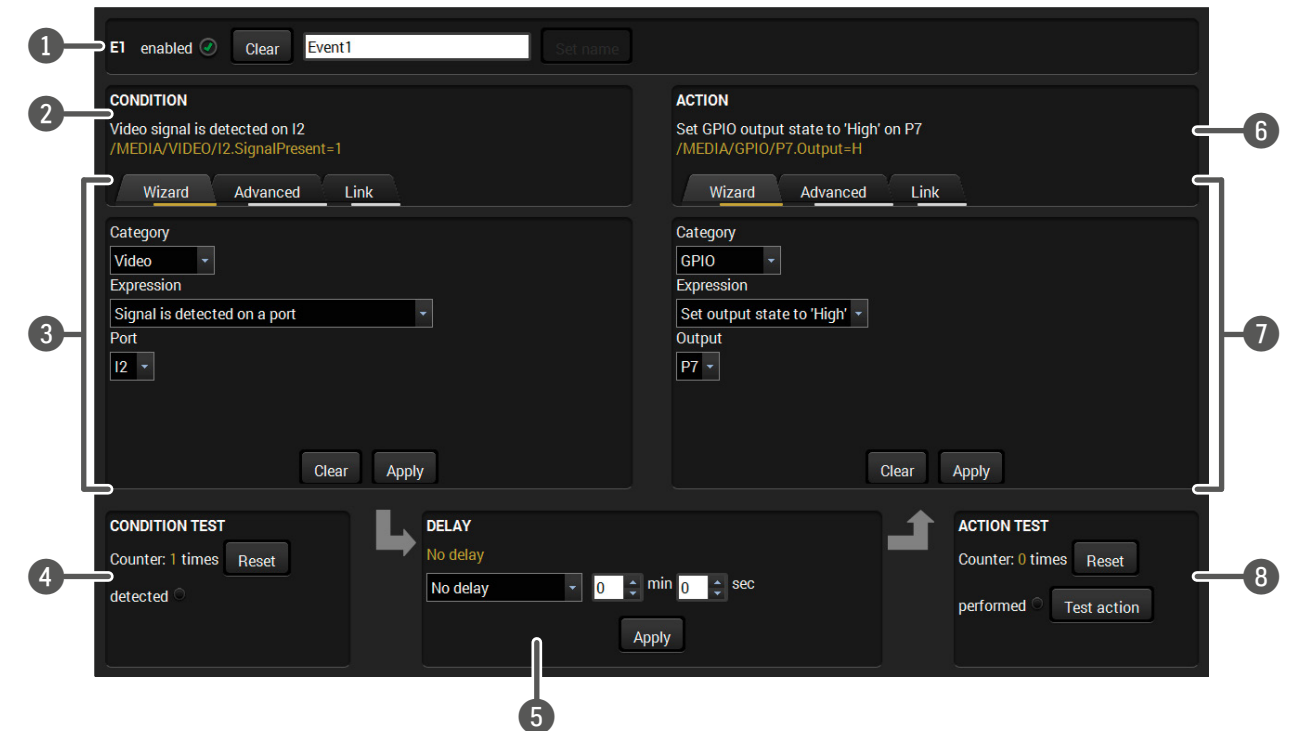

- 1 **Event header** The name of the Event is displayed. Type the desired name and press the Set name button. The Event can be cleared by the Clear button. Use the tick mark to enable/disable the Event.
- 2 **Condition header** If the condition is set, the description (white colored text) and the exact LW3 protocol expression (yellow colored text) can be seen. If the advanced mode was used the description is "Custom condition".
- 3 **Condition panel** The Wizard, the Advanced or the Link tool is available to set the condition. The parameters and settings are displayed below the buttons.
- 4 **Condition test** The set condition can be tested to see the working method in the practice.
- 5 **Delay settings** The action can be scheduled to follow the condition after the set time value.
- 6 **Action header** If the action is set, the description (white colored text) and the exact LW3 protocol expression (yellow colored text) can be seen. If the advanced mode was used the description is "Custom action".
- 7 **Action panel** The Wizard, the Advanced or the Link tool is available to set the action. The parameters and settings are displayed below the buttons.
- 8 **Action test** The set action can be tested to see the working method in the practice.

### 5.9.1. Create or Modify an Event

#### Wizard Mode

The wizard mode lists the most common conditions and actions, so the user does not have to look for LW3 nodes and properties.

- Step 1.** Click on the **Edit** button of the desired Event; the **Event editor** is displayed.
- Step 2.** The wizard mode is displayed as default. Select the desired **Category** first (e.g. Audio or Video).
- Step 3.** Select the desired **Expression** from the drop-down menu. If any other parameter is necessary to set, it is going to be displayed.
- Step 4.** Press the **Apply** button to store the settings of the Condition.

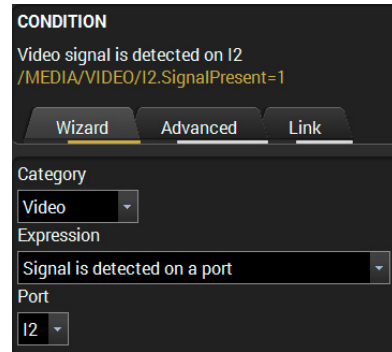

#### Advanced Mode

The goal of this mode is the same as of the wizard: set the properties and methods for conditions and actions. The difference is the number of the available and usable properties and methods of the LW3 protocol. Advanced mode allows almost all of it.

- Step 1.** Click on the **Edit** button of the desired Event; the **Event editor** is displayed.
- Step 2.** The wizard mode is the default, press the **Advanced** button. The LW3 protocol tree is displayed showing the list of the properties in the drop-down menu. Navigate to the desired node.
- Step 3.** Select the desired **Property** from the menu. The **manual** of the property is displayed below to help to select the necessary property and to set the value.
- Step 4.** Set the desired **value** and **operator**, then press the **Apply** button to store settings.

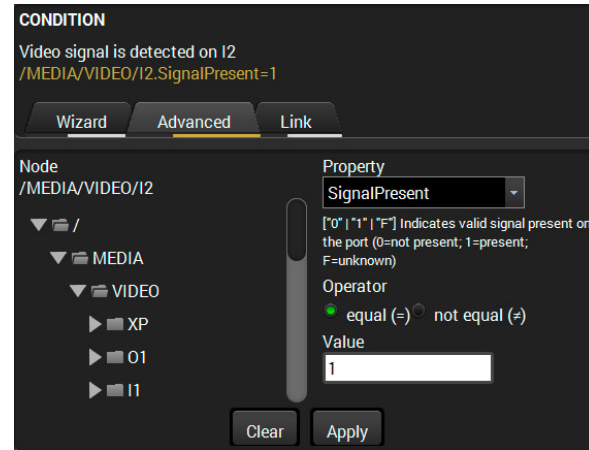

#### The Link Tool

The new interface allows creating more actions to the same condition. In that case, a condition can trigger more actions. To set such an Event, the Link tool has been introduced.

- Step 1.** Click on the **Edit** button of the desired Event; the **Event editor** is displayed.
- Step 2.** The wizard mode is displayed as default, press the **Link** button.
- Step 3.** All the saved Events are analyzed and the **conditions** are listed (it takes some seconds to finish). The **Show advanced expressions** option allows showing the exact path and set the value of the given property.
- Step 4.** Select the desired **Condition** and press the **Apply** button to store the settings.

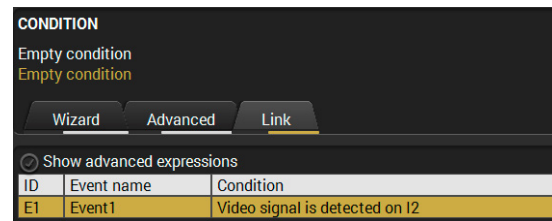

### 5.9.2. Special Tools and Accessories

#### The Name of the Event

The name of a port can be changed by typing the new name and clicking the **Set** button. The following characters are allowed when naming:

Letters (A-Z) and (a-z), numbers (0-9), special characters: hyphen (-), underscore (\_), and space ( ).

#### Enable or Disable an Event

The set Event can be enabled or disabled in the Event list, or directly in the Event editor window by setting the **tick mark** beside the name.

#### Testing the Condition

When the desired Condition is arranged, the setting can be tested. The Event list and the Event editor contains a small panel that shows if the set condition is detected and how many times. The **Counter** can be reset by the button in Event editor. If the Condition is true, the **detected** mark turns green for two seconds and the **Counter** is increased.

#### Testing the Action

The method is the same as testing the Condition, but in this case, the Action can be triggered manually by pressing the **Test** button.

**TIPS AND TRICKS:** The Test button is also placed on the Action panel in the Event list. Thus, you can check the Actions without opening the Event editor.

#### Delay the Action

In most cases the Action is performed immediately after the Condition is detected. But sometimes a delay is necessary between the Condition and the Action. Therefore, the new Event manager contains the Delay panel which allows that feature with below settings:

- **No delay:** when the Condition is detected, the Action is launched.
- **Simple delay:** when the Condition is detected, the Action is launched after the set time interval.
- **Still exists:** when the Condition is detected, the Action is launched after the set time interval only if the Condition still exists.
- **Continuously exist:** when the Condition is detected, the Action is launched after the set time interval only if the Condition has been existing continuously.

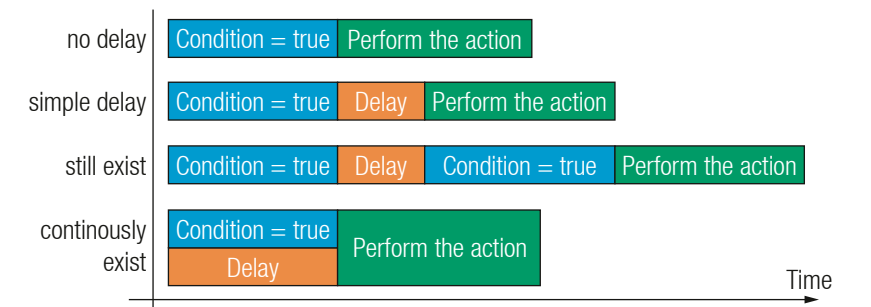

**TIPS AND TRICKS:** **Show advanced expressions** option is a useful tool when you look for the path or value of a property. The option is available in the Event list window or when Link tool is used.

### 5.9.3. Clear One or More Event(s)

#### Clear an Event

Press the **Clear** button in the Event list or in the header section in the Event editor.

#### Clear all Events

When all the Events must be cleared press the **Load factory defaults** button above the Event list. You will be prompted to confirm the process.

### 5.9.4. Export and Import Events

The feature allows saving all the Events. The backup file can be uploaded to another HDMI-3D-OPT series extender.

#### Export all the Events

**Step 1.** Press the **Export** button above the Event list.

**Step 2.** The Save as dialog box will appear. Set the desired folder and file name, then press the **Save** button.

The generated file is a simple text file which contains LW3 protocol commands. The file can be viewed by a simple text editor, e.g. Notepad.

**ATTENTION!** Editing the file is recommended only for expert users.

#### Import all the Events

**Step 1.** Press the **Import** button above the Event list.

**Step 2.** The Open dialog box will appear. Select the desired folder and file, then press the **Open** button.

### 5.9.5. Event Creating - Example

The following example shows you on a real-life situation how to set up an Event.

#### The Concept

The SW4-OPT-TX240RAK is connected to a projector by the optical output port. The transmitter is also connected to the projector by the RS-232 port and can send commands via the serial line.

The task is to turn on the projector when signal is detected on the optical output port.

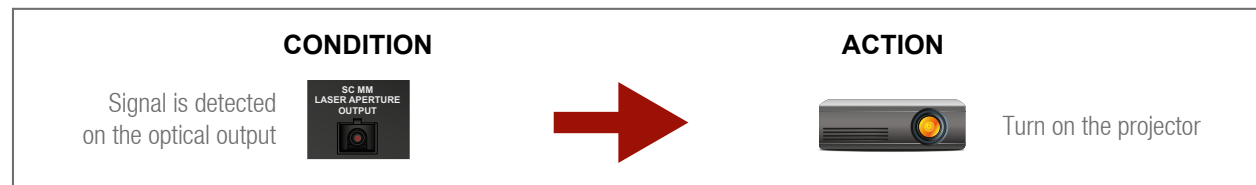

#### RS-232 Settings

Make sure that the serial line is established between the transmitter and the projector. Check that the RS-232 settings of the transmitter is set exactly the same which required for the projector: baud rate, data bits, parity, stop bits. The transmitter needs to be set to: Control protocol: LW3; and RS-232 mode: Pass-through. See the relevant LDC settings in the [RS-232](#) section.

#### Setting the Event

You can create the Event in the Wizard in few simple steps:

**Step 1.** Set the condition.

Select the required parameters to set the condition:

- **Category:** Video;
- **Expression:** Signal is detected on a port;
- **Port:** O1.

Click on the **Apply** button to complete the procedure. When it is done, the condition appears on the upper side in textual and LW3 command format as well.

**Step 2.** Set the action.

If the condition is fulfilled, the following action needs to be launched: the receiver sends a command to the projector over the serial line:

- **Power on** - the required command which is accepted by the projector: PWR0<CR><LF>

For this instance the command has to be closed with the <CR><LF> characters so they need to be escaped. You can use the following format for escaping:

```
<command1><\x0d\x0a><command2><\x0d\x0a>...
...<commandn><\x0d\x0a>
```

In the current case the command is: PWR0\x0d\x0a

Select the required parameters to set the action:

- **Category:** RS-232;
- **Expression:** Send RS-232 message;
- **Port:** P1;
- **Message:** PWR0\x0d\x0a

**Step 3.** Enable the Event.

Select the **E1 enabled** pipe in upper left corner to set the Event as launched.

**INFO:** If you do not find the required category/expression/etc what you need, choose the Advanced mode in the Wizard where the entire LW3 structure tree is available. For example instead of signal detection you can set a specified resolution or color range either as a condition.

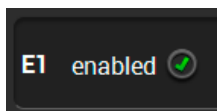
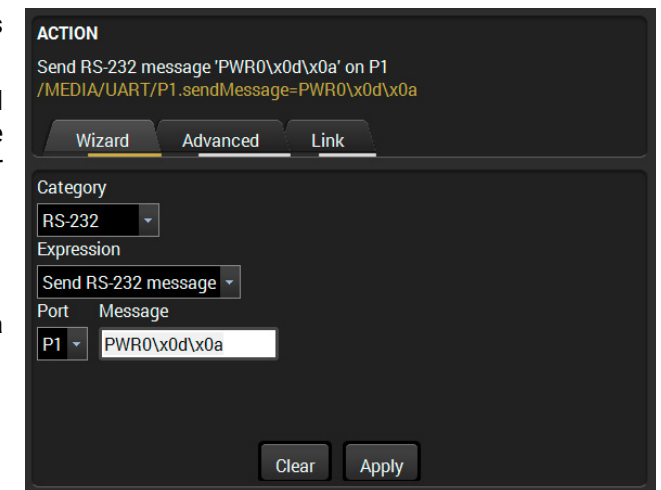
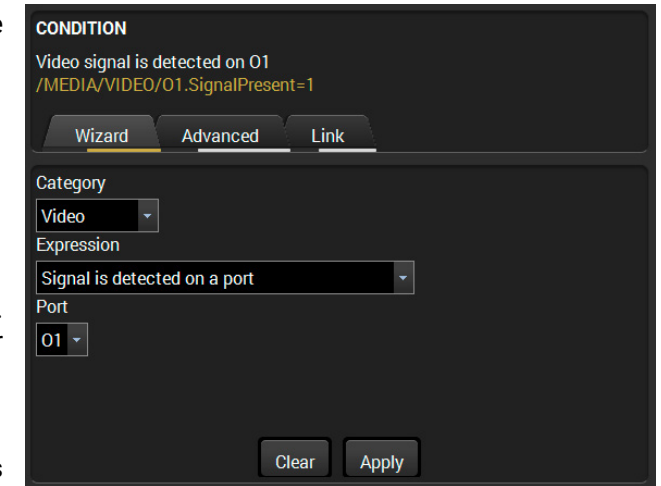

## 5.10. Settings Menu

### 5.10.1. Status

The screenshot displays the 'Status' tab within the 'Settings' menu. The device name is SW4-OPT-TX240RAK. The interface is divided into several sections:

- General:** Device name (SW4-OPT-TX240RAK), Hardware version (V10\_DAA0), Device label (SW4-OPT-TX240RAK with a 'Set' button), Part number (91510027), Serial number (00004148), Omron type (D), Omron serial number (5TBGP52369H), and MAC address (a8:d2:36:00:41:48).
- Operation:** System uptime (0 days 00h 01m 22s), Operation time (12 days 22h 36m 21s), and High temp operation time (0 days 00h 00m 00s).
- Firmware versions:** CPU firmware version (1.1.0b5 r8) and DP Chip Firmware version (1.0.4b0 r101).
- Temperatures:** CPU temperature (46 °C, 22 °C min, 53 °C max) and System temperature (46 °C, 22 °C min, 52 °C max).
- Voltages:** 1.3V (1.3 V, 1.29 V min, 1.3 V max), 1.8V (1.89 V, 1.88 V min, 3.26 V max), 3.3V (3.25 V, 3.25 V min, 3.3 V max), ADAU 3.3V (3.3 V, 3.29 V min, 4.99 V max), and Main 5V (4.99 V, 4.87 V min, 4.99 V max).
- Reset measurements:** A 'Reset' button with a circular arrow icon.

An 'Advanced view' button is located at the bottom right of the panel.

*Status tab in Settings menu*

The most important hardware and software related information can be found on this tab: hardware and firmware version, serial numbers, temperatures, operation time, and voltage information. Device label can be changed to unique description by the **Set** button.

### 5.10.2. Network

The screenshot displays the 'Network' tab within the 'Settings' menu. The device name is SW4-OPT-TX240RAK. The interface shows the following network configuration options:

- General:**
  - Current IP address: 192.168.0.79
  - Current subnet mask: 255.255.255.0
  - Current gateway address: 192.168.0.1
  - Obtain IP address automatically (DHCP, AutoIP):
  - Static IP address: 192.168.0.79
  - Static subnet mask: 255.255.255.0
  - Static gateway address: 192.168.0.1
  - LW2 port: 10001
  - LW3 port: 6107
  - HTTP port: 80
- Apply changes:** Buttons for 'Apply changes', 'Cancel', and 'Load factory defaults'.

An 'Advanced view' button is located at the bottom right of the panel.

*Network tab in Settings menu*

IP address and DHCP settings can be set on this tab. Always press the **Apply settings** button to save changes. Factory defaults settings can be recalled with a dedicated button.

### 5.10.3. Backup

Details about this function can be found in the [Configuration Cloning \(Backup Tab\)](#) section.



### 5.10.4. System

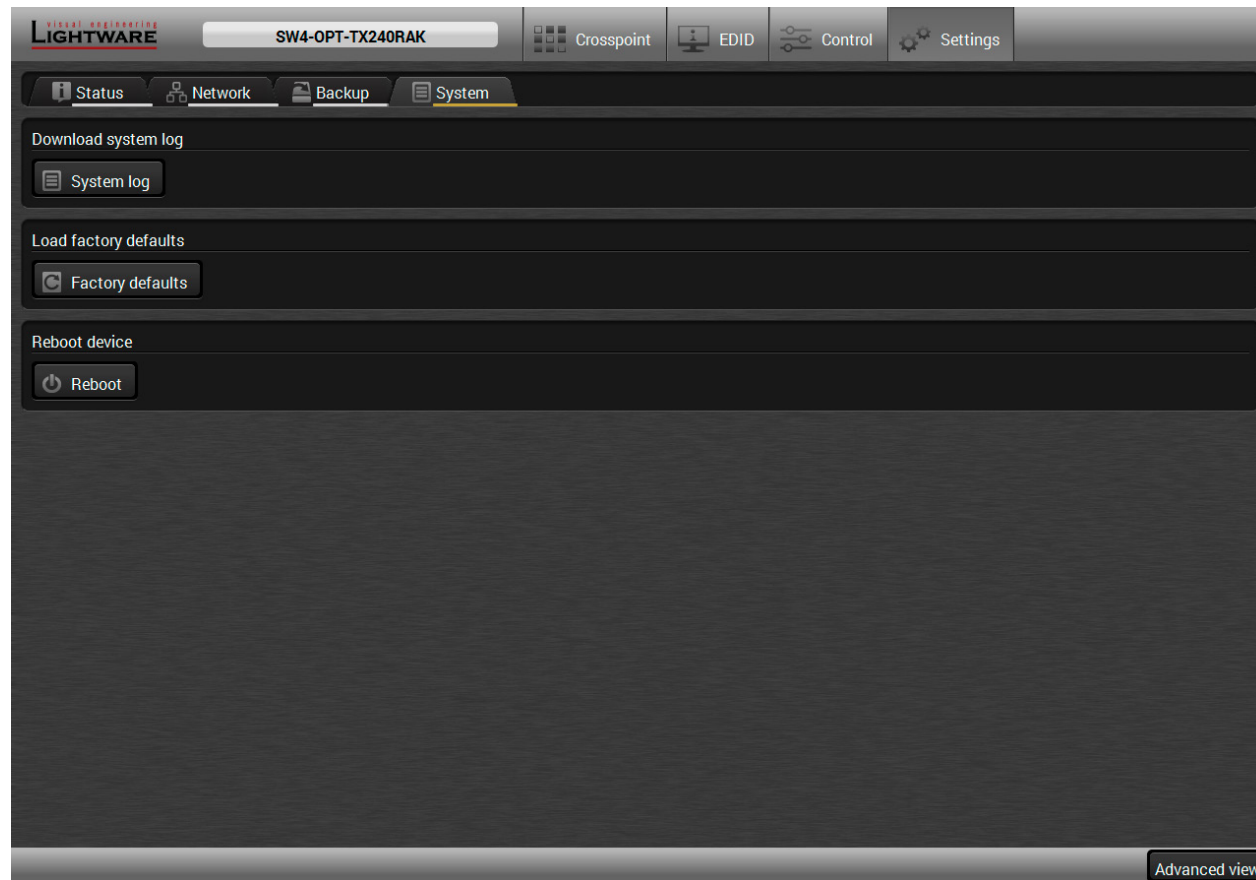

*System tab in Settings menu*

Three functions are available under System tab:

- **Download system log** - saving the file of the device.
- **Load factory defaults** - recalling factory defaults settings and values. All factory default settings are listed in the [Factory Default Settings](#) section.
- **Reboot** - rebooting the system.

### 5.11. Configuration Cloning (Backup Tab)

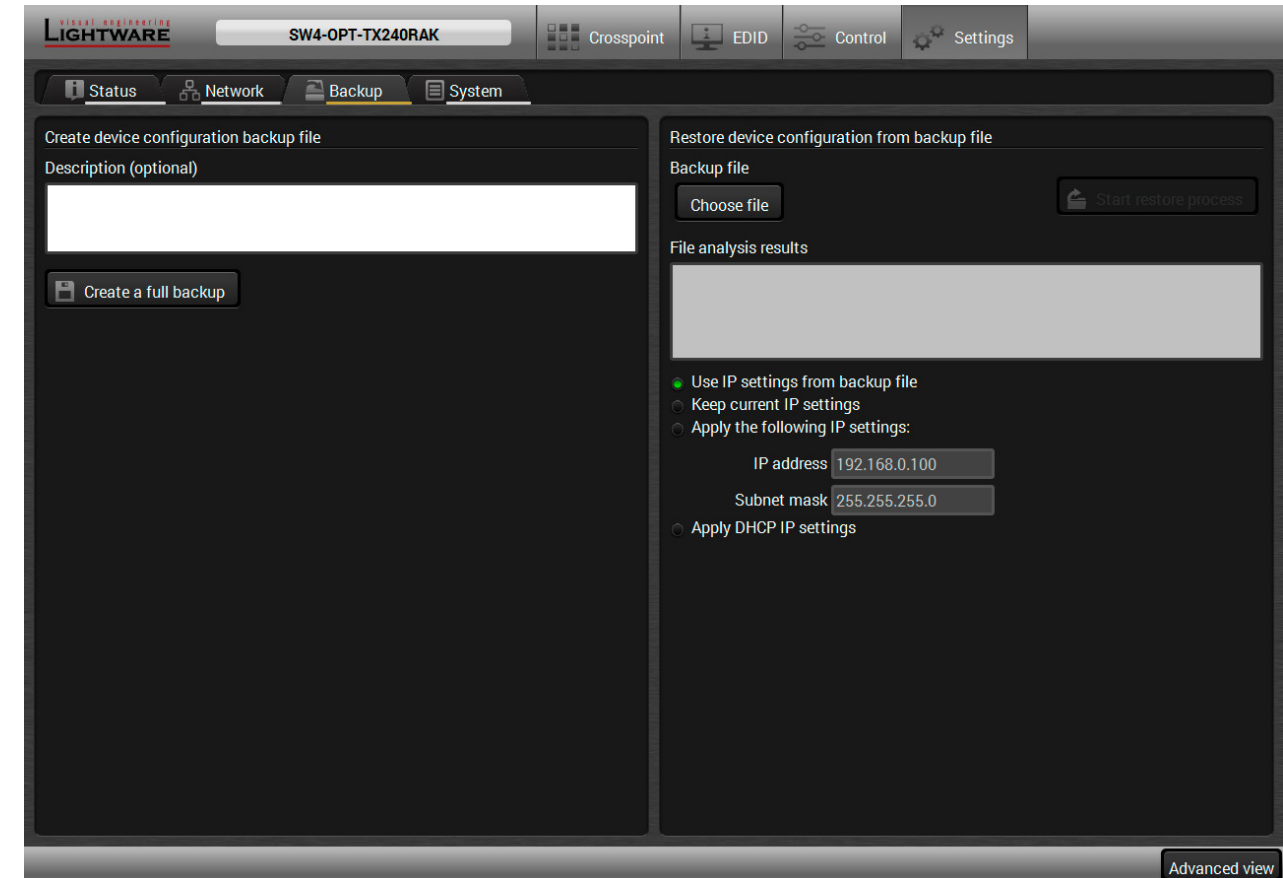

*Backup tab in Settings menu*

Configuration cloning of Lightware LW3 devices is a simple method that eliminates the need to repeatedly configure certain devices to have identical (non-factory) settings. If the devices are installed in the same type of system multiple times then it is enough to set up only one device to fit the user's needs and then copy those settings to the others, thus saving time and resources.

#### 5.11.1. Steps in a Nutshell

Installing multiple devices with the same customized configuration settings can be done in a few easy steps:

**Step 1.** Configure one device with all your desired settings using the LDC software.

**Step 2.** Backup the full configuration file to your computer.

**Step 3.** If needed, make some modifications to the configuration file using a text editor (e.g. Notepad). E.g. modifying the static IP address is necessary when DHCP is not used.

**Step 4.** Connect to the other device which has to be configured and upload (restore) your configuration file.

**Step 5.** Done! You can have as many totally identical, customized devices as you like.

### 5.11.2. Save the Settings of a Device (Backup)

- Step 1.** Apply the desired settings in the transmitter (port parameters, crosspoint, etc.)
- Step 2.** Select the **Settings / Backup** tab from the menu.
- Step 3.** Write a short **description** in the text box on the left (optional).
- Step 4.** Press the **Create a full backup** button. You will be prompted to save the file to the computer. The default file name is the following:

```
BACKUP_<DEVICE TYPE>_SN<SERIAL NUMBER>.LW3
```

- Step 5.** Set the desired **file name**, select the folder and **save** the file.

**TIPS AND TRICKS:** Using the exact product type in the filename is recommended since it makes the file usage more comfortable.

#### About the Backup File

The backup file is a simple text file which contains LW3 protocol commands. The first line is the description and the further lines are the commands which will be executed during the restore process. The file can be viewed (and/or edited) by a simple text editor, e.g. Notepad.

See the entire list of saved data in the [Content of Backup File](#) section.

**ATTENTION!** Editing the command lines is only recommended for expert users.

### 5.11.3. Upload the Settings to a Device (Restore)

**WARNING! Please note that the settings will be permanently overwritten with the restored parameters in the device. Undo is not available.**

**ATTENTION!** The cloning is successful when the backup file is downloaded from the same type of source device as the destination device.

#### The Restoring Process

- Step 1.** Select the **Settings / Backup** tab from the menu.
- Step 2.** Click on the **Choose file** button on the right panel and **browse** to the desired file.
- Step 3.** The file is verified and the result will be displayed in the textbox below. If the file is correct, then the settings can be restored.
- Step 4.** Choose **IP settings** what you want to use after backup. You can apply settings from the backup file, keep actual settings, set it manually in a dialog box or apply DHCP.
- Step 5.** Press the **Start restore process** button and click on the **Yes** button when asked.
- Step 6.** Reboot the device to apply the network settings after finishing.

### 5.12. Advanced View Window

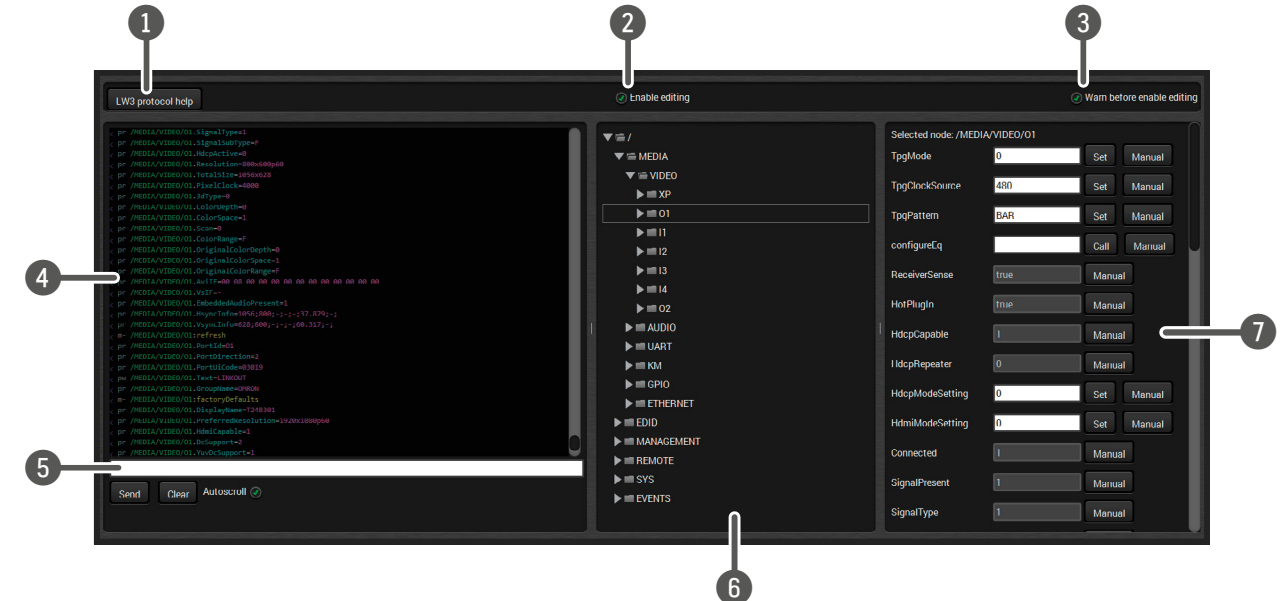

- 1 LW3 protocol help** Pushing the button results a help window opening which describes the most important information about LW3 protocol commands in HTML format.
- 2 Edit mode** The default appearance is the read-only mode. If you want to modify the values or parameters, tick the option. You will be prompted to confirm your selection.
- 3 Warning mode** If this pipe checked in, a warning window pops up when you enable Edit mode.
- 4 Terminal window** Commands and responses with time and date are listed in this window. Sent command starts with '>' character, received response starts with '<' character. The color of each item depends on the type of the command and response. The content of the window can be emptied by the **Clear** button. If the **Autoscroll** option is ticked, the list is scrolled automatically when a new line is added.
- 5 Command line** Type the desired command and execute it by the **Send** button. Clear all current commands and responses in the Terminal window by the **Clear** button.
- 6 Protocol tree** LW3 protocol tree; select an item to see its content.
- 7 Node list** Correspondent parameters and nodes are shown which are connected to the selected item in the protocol tree.
  - Manual button:** Manual (short description) of the node can be called and displayed in the terminal window.
  - Set button:** Saves the value/parameter typed in the textbox.
  - Call button:** Calls the method, e.g. reloads factory default settings.

# 6

## LW2 Programmer's Reference

The device can be controlled through a reduced command set of LW2 protocol commands to ensure the compatibility with other Lightware products. The supported LW2 commands are described in this chapter.

- ▶ LW2 PROTOCOL DESCRIPTION
- ▶ GENERAL LW2 COMMANDS
- ▶ A/V PORT SETTINGS
- ▶ NETWORK CONFIGURATION
- ▶ GPIO CONFIGURATION
- ▶ LW2 COMMANDS – QUICK SUMMARY

### 6.1. LW2 Protocol Description

The device accepts commands surrounded by curly brackets - {} - and responds data surrounded by round brackets - () - only if a command was successfully executed.

Format	Explanation
<in>	Input number in 1 or 2 digit ASCII format (01, 5, 07, 16, etc.)
<out>	Output number in 1 or 2 digit ASCII format
<in <sup>2</sup> >	Input number in 2 digit ASCII format (01, 02, 10, 12 etc.)
<out <sup>2</sup> >	Output number in 2 digit ASCII format (01, 02, 10, 12 etc.)
<loc>	Location number in 1, 2 or 3 digit ASCII format
<id>	id number in 1 or 2 digit ASCII format
<id <sup>2</sup> >	id number in 2 digit ASCII format
CrLf	Carriage return, Line feed (0x0D, 0x0A)
•	Space character (0x20)
→	Each command issued by the controller
←	Each response received from the router

### 6.2. General LW2 Commands

#### 6.2.1. View Product Type

**Description:** The device responds its name.

Format	Example
Command {i} Response (I:<PRODUCT_TYPE>)CrLf	→ {i} ← (I:SW4-OPT-TX240RAK)

**Explanation:** The connected device is a SW4-OPT-TX240RAK.

**Legend:** <PRODUCT\_TYPE> shows type.

#### 6.2.2. Query Control Protocol

**Description:** The device can be controlled with different control protocols. This command queries the active protocol of the currently used control interface.

Format	Example
Command {P_?} Response (CURRENT•PROTOCOL•#<protocol>) CrLf	→ {p_?} ← (CURRENT PROTOCOL = #1)

**Explanation:** The device communicates with LW2 protocol.

### 6.2.3. View Firmware Version of the CPU

**Description:** View the CPU firmware revision.

Format	Example
Command {f} Response (FW:<FW_VER><s>)CrLf	→ {f} ← (FW:1.1.0b5 r8)

**Legend:** <FW\_VER> is the firmware version. It is followed by <s> string which may indicate special versions.

### 6.2.4. Connection Test

**Description:** Simple test to see if the connection is established successfully.

Format	Example
Command {PING} Response (PONG!)CrLf	→ {ping} ← (PONG!)

### 6.2.5. View Serial Number

**Description:** The device responds its 8-digit serial number.

Format	Example
Command {s} Response (SN:<SERIAL_N>)CrLf	→ {s} ← (SN:5A003192)

### 6.2.6. Compile Time

**Description:** Returns the date, when the microcontroller firmware was compiled.

Format	Example
Command {CT} Response (Complied: <DATE&TIME>)CrLf	→ {ct} ← (Compiled: Jul 13 2017 11:17:56)

### 6.2.7. View Installed Board

**Description:** Shows the hardware name and revision of the installed card.

Format	Example
Command {is} Response (SL#●●●<MB_DESC>)CrLf (SL●END)CrLf	→ {is} ← (SL# 0 SW4-OPT-TX240RAK V11_DAA0) ← (SL END)

**Explanation:** The device reports its motherboard (slot 0).

### 6.2.8. View Firmware for All Controllers

**Description:** Shows the firmware versions of all installed controllers.

Format	Example
Command {FC} Response (CF●<DESC>)CrLf (CF●<DESC>)CrLf ... (CF END)CrLf	→ {fc} ← (CF SW4-OPT-TX240RAK 1.1.0b5 r8)   ← (SL END)

**Explanation:** The device has one control panel.

### 6.2.9. Restart the Device

**Description:** The device can be restarted without unplugging power.

Format	Example
Command {RST} Response	→ {rst}

**Explanation:** The device reboots; no response is sent in this case.

### 6.2.10. Query Health Status

**Description:** Internal voltages and measured temperature values are shown.

Format	Example
Command {ST} Response (ST●<DESC>)CrLf	→ {st} ← (ST CPU 1.29V 1.89V 3.25V 3.30V 4.99V 47.44C 47.43C)

### 6.2.11. Restore Factory Default Settings

**Description:** Settings can be reset to factory default values as follows:

Format	Example
Command {FACTORY=ALL} Response (FACTORY ALL...)CrLf	→ {factory=all} ← (FACTORY ALL...)

**Explanation:** All settings and parameters are reset to factory default, see the table in the [Factory Default Settings](#) section.

## 6.3. A/V Port Settings

### 6.3.1. Switch an Input to the Outputs

Following commands with <A/V/AV> option can take effect in multiple layers, according to their parameters. Depending on 'A' or 'V' it can change only the Audio or only the Video layer; or 'AV' changes both.

INFO: <A/V/AV> option usually can be skipped for legacy purposes. In this case, the devices change all (Video & Audio) layers but using status commands it displays information about only the Video layer. Please use AV option, when available.

**Description:** Switch input <in> to output <out>.

Format	Example
Command {<in>@<out>●<layer>} Response (O<out>²●<in>²●<layer>)CrLf	→ {2@1 AV} ← (001 I02 AV)

**Explanation:** I2 audio and I2 video input ports are switched to O1 output port.

**Legend:**

<layer>	Layer
A	Audio layer
V	Video layer
AV (or nothing)	Audio & Video layer

<out>: O1 output port.  
<in>: I1...I6 input ports.

**ATTENTION!** The response of this command does not show if the output is muted. To check the mute status a separate query has to be used like {VC}.

**ATTENTION!** Analog video inputs does not contain embedded audio. If you use the AV option in case of VGA input (I1) the audio will be switched to the analog audio input 1 (I1) and in case of DVI-A input (I5) the audio will be switched to the analog audio input 2 (I5).

### 6.3.2. Mute Output

**Description:** Mute output <out>. The output signal is turned off.

Format	Example
Command {#<out>●<layer>} Response (1MT<out>²●<layer>)CrLf	→ {#01 A} ← (1MT01 A)

**Explanation:** O1 audio port is muted.

**ATTENTION!** Muting does not change the crosspoint's state but disables the output itself. This way the last connection can be easily restored with an unmute command. Switching a muted output does not unmute the output.

### 6.3.3. Unmute Output

**Description:** Unmute output <out>.

Format	Example
Command {+<out>●<layer>} Response (0MT<out>²●<layer>)CrLf	→ {+01 V} ← (0MT01 V)

**Explanation:** O1 video port is unmuted.

INFO: Unmuting an output makes the previous connection active as the crosspoint state has not been changed by the muting command, only the output was disabled.

### 6.3.4. Lock Output

**Description:** Lock an output port. Output's state cannot be changed until unlocking.

Format	Example
Command {#<out>●<layer>} Response (1LO<out>²●<layer>)CrLf	→ {#>01 A} ← (1LO01 A)

**Explanation:** O1 audio output port is locked.

### 6.3.5. Unlock Output

**Description:** Unlock an output port. The connection on output can be changed.

Format	Example
Command {+<out>●<layer>} Response (0LO<out>²●<layer>)CrLf	→ {+<out> V} ← (0LO01 V)

**Explanation:** O1 video output port is unlocked.

INFO: The device issues the above response regardless of the previous state of the output (either it was locked or unlocked).

### 6.3.6. View Connection State on the Output

**Description:** Viewing the crosspoint state of the device; showing the input port numbers connected to the outputs.

Format	Example
Command {VC<layer>} Response (ALL<layer>●<001>●<002>)CrLf	→ {VC AV} ← (ALLV 04 04) ← (ALLA 06 06)

**Legend:** 001 shows the corresponding output's connection state.

<layer>	Layer
A	Audio layer
V	Video layer
AV *	Audio & Video layer

\* AV is not used in the response. When AV is typed in the commands, the response will result two lines, one for the Video and one for the Audio port states.

**State letters:**

Letter	State	Example
L	Output is locked	L01
M	Output is muted	M01
U	Output is locked and muted	U01

**Explanation:** I4 video input port is connected to the video output ports and I6 audio input port is connected to the audio output ports.

### 6.3.7. View Crosspoint Size

**Description:** Shows the physical crosspoint size.

Format	Example
Command {getsize●<layer>} Response (SIZE=<size>●<layer>)CrLf	→ {GETSIZE AV} ← (SIZE=4x2 V) ← (SIZE=6x2 A)

**Legend:**

<size>: <number of inputs>x<number of outputs>  
<layer>: See details in the previous section.

**Explanation:** The device reports that it has a video crosspoint with 4 inputs and 2 outputs and an audio crosspoint with 6 inputs and 2 outputs.

### 6.3.8. Change Video Autoselect Mode

**Description:** The autoselect mode of the video outputs can be changed.

Format	Example
Command {AS_V<out>=<state>;<mode>} Response (AS_V<out>=<state>;<mode>)CrLf	→ {as_v1=E;P} ← (AS_V1=E;P) ← (AS_V2=E;P)

**Legend:** The output port numbers are listed in [Input/Output Port Numbering](#) section.

Letter	<state>
F	First detect mode
P	Priority detect mode
L	Last detect mode

Letter	<mode>
E	Autoselect mode is enabled
D	Autoselect mode is disabled

**Explanation:** The Autoselect mode of video output 1 and output 2 is enabled and set to Priority mode.

INFO: The Autoselect mode can be queried by typing the "as\_v<out>=?" command.

### 6.3.9. Change Audio Autoselect Mode

**Description:** The autoselect mode of the audio outputs can be changed.

Format	Example
Command {AS_A<out>=<state>;<mode>} Response (AS_A<out>=<state>;<mode>)CrLf	→ {as_a1=E;P} ← (AS_A1=E;P) ← (AS_A2=E;P)

**Legend:** The output port numbers are listed in [Input/Output Port Numbering](#) section.

Letter	<state>
F	First detect mode
P	Priority detect mode
L	Last detect mode

Letter	<mode>
E	Autoselect mode is enabled
D	Autoselect mode is disabled

**Explanation:** The Autoselect mode of audio output 1 and output 2 is enabled and set to Priority mode.

INFO: The Autoselect mode can be queried by typing the "as\_v<out>=?" command.

### 6.3.10. Change the Video Input Priorities

**Description:** The settings of video input priority can be changed as follows.

Format	Example
Command {PRIO_V<out>=<in <sup>1</sup> _prio>;<in <sup>2</sup> _prio>;...;<in <sup>n</sup> _prio>} Response (PRIO_V<out>=<in <sup>1</sup> _prio>;<in <sup>2</sup> _prio>;...;<in <sup>n</sup> _prio>)CrLf	→ {prio_v1=1;0;2;3} ← (PRIO_V1=1;0;2;3)

**Legend:**

<out>: The output port number: V1/V2.  
<in<sup>1</sup>\_prio>...<in<sup>n</sup>\_prio>: Priority number of the input ports. See more details about port numbering in the [Input/Output Port Numbering](#) section.

**Explanation:** Input 2 has the highest priority (0), Input 1 has the second highest (1). Input 4 has the lowest priority (3).

**ATTENTION!** Always set all the priority of the ports when changing, otherwise, the change will not be executed and the response will be the current setting (like querying the priority setting).

**INFO:** In this case, the outputs are linked; the change will affect both local and fiber optical output ports.

**INFO:** The video priorities can be queried by typing the “prio\_v<out>=?” command.

### 6.3.11. Change the Audio Input Priorities

**Description:** The settings of video input priority can be changed as follows.

Format	Example
Command {PRIO_A<out>=<in <sup>1</sup> _prio>;<in <sup>2</sup> _prio>;...;<in <sup>n</sup> _prio>} Response (PRIO_A<out>=<in <sup>1</sup> _prio>;<in <sup>2</sup> _prio>;...;<in <sup>n</sup> _prio>)CrLf	→ {prio_a1=1;0;2;3;4;5} ← (PRIO_A1=1;0;2;3;4;5)

**Legend:**

<out>: The output port number: A1/A2.  
<in<sup>1</sup>\_prio>...<in<sup>n</sup>\_prio>: Priority number of the input ports. See more details about port numbering in the [Input/Output Port Numbering](#) section.

**Explanation:** Input 2 has the highest priority (0), Input 1 has the second highest (1). Input 6 has the lowest priority (5).

**ATTENTION!** Always set all the priority of the ports when changing, otherwise, the change will not be executed and the response will be the current setting (like querying the priority setting).

**INFO:** In this case, the outputs are linked; the change will affect both local and fiber optical output ports.

**INFO:** The audio priorities can be queried by typing the “prio\_a<out>=?” command.

## 6.4. Network Configuration

### 6.4.1. Query the Current IP Status

**Description:** IP address settings can be queried as follows.

Format	Example
Command {IP_STAT=?} Response (IP_STAT=<type>;<ip_address>;<subnet_mask>;<gateway_addr>)CrLf	→ {ip_stat=?} ← (IP_STAT=0;192.168.0.100;255.255.255.0;192.168.0.1)

**Legend:**

<type>: 0 = static IP; 1 = DHCP.  
<ip\_addr>: IP address (four decimal octets separated by dots).  
<subnet\_mask>: Subnet mask (four decimal octets separated by dots).  
<gateway\_addr>: Gateway address (four decimal octets separated by dots).

**Explanation:** The device has a static (fix) IP address: 192.168.0.100; the subnet mask is 255.255.255.0, the gateway address is 192.168.0.1.

### 6.4.2. Set the IP Address

**Description:** IP address can be set as follows.

Format	Example
Command {IP_ADDRESS=<type>;<ip_address>} Response (IP_ADDRESS=<type>;<ip_address>)CrLf	→ {ip_address=0;192.168.0.110} ← (IP_ADDRESS=0;192.168.0.110)

**Legend:** <type>: 0 = static IP; 1 = DHCP

**INFO:** The IP address can be queried by typing the “ip\_address=?” command. The response contains the fix IP address that is stored in the device even if DHCP is enabled; in this case, this IP address is not valid.

### 6.4.3. Set the Subnet Mask

**Description:** Subnet mask can be set as follows.

Format	Example
Command {IP_NETMASK=<subnet_mask>} Response (IP_NETMASK=<subnet_mask>)CrLf	→ {ip_netmask=255.255.255.0} ← (IP_NETMASK=255.255.255.0)

**Legend:** <subnet\_mask>: Four decimal octets separated by dots.

**INFO:** The subnet mask can be queried by typing the “ip\_address=?” command. The response contains the fix IP subnet mask that is stored in the device even if DHCP is enabled; in this case, this IP subnet mask is not valid.

#### 6.4.4. Set the Gateway Address

**Description:** Gateway address can be set as follows.

Format	Example
Command {IP_GATEWAY=<gateway_addr>}	→ {ip_gateway=192.168.0.50}
Response (IP_GATEWAY=<gateway_addr>)CrLf	← (IP_GATEWAY=192.168.0.50)

**Legend:** <gateway\_addr>: Four decimal octets separated by dots.

INFO: The gateway address can be queried by typing the "ip\_gateway=?" command. The response contains the static IP gateway address that is stored in the device even if DHCP is enabled. In that case, the latest valid gateway address (for static IP) is stored.

#### 6.4.5. Apply Network Settings

**Description:** Apply the network settings and restart the network interface.

Format	Example
Command {ip_apply}	→ {ip_apply}
Response (IP_APPLY)CrLf	← (IP_APPLY)

### 6.5. GPIO Configuration

#### 6.5.1. Set Level and Direction for Each Pins

**Description:** GPIO pins can be configured as follows. See more details about GPIO connector in the section and about the interface in the section.

Format	Example
Command {GPIO<pin_nr>=<dir>;<level>}	→ {gpio1=0;H}
Response (GPIO<pin_nr>=<dir>;<level>)CrLf	← (GPIO1=0;H)

**Legend:**

- <pin\_nr>: GPIO pin number 1...8
- <dir>: The direction of the communication, it can be input or output.
- <level>: The level of the pin, it can be low or high.

Parameter <dir>	Description
I	Input
O	Output

Parameter <level>	Description
L	Low
H	High
T	Toggle

**Explanation:** GPIO pin 1 is set to output with high level.

INFO: The current GPIO pin configuration can be queried by typing the {GPIO<pin\_nr>=?} command.



## 6.6. LW2 Commands – Quick Summary

### General LW2 Commands

Operation	See in section	Command
View Product Type	6.2.1	{I}
Query Control Protocol	6.2.2	{P_?}
View Firmware Version of the CPU	6.2.3	{F}
Connection Test	6.2.4	{PING}
View Serial Number	6.2.5	{S}
Compile Time	6.2.6	{CT}
View Installed Board	6.2.7	{IS}
View Firmware for All Controllers	6.2.8	{FC}
Restart the Device	6.2.9	{RST}
Query Health Status	6.2.10	{ST}
Restore Factory Default Settings	6.2.11	{FACTORY=ALL}

### A/V Port Settings

Operation	See in section	Command
Switch an Input to the Outputs	6.3.1	{<in>@<out>●<layer>}
Mute Output	6.3.2	{#<out>●<layer>}
Unmute Output	6.3.3	{+<out>●<layer>}
Lock Output	6.3.4	{#><out>●<layer>}
Unlock Output	6.3.5	{+<out>●<layer>}
View Connection State on the Output	6.3.6	{VC●<layer>}
View Crosspoint Size	6.3.7	{GETSIZE●<layer>}
Change Video Autoselect Mode	6.3.8	{AS_V<out>=<state>;<mode>;<no_signal>}
Change Audio Autoselect Mode	6.3.9	{AS_A<out>=<state>;<mode>;<no_signal>}
Change the Video Input Priorities	6.3.10	{PRIO_V<out>=<in_1_prio>;...;<in_n_prio>}
Change the Audio Input Priorities	6.3.11	{PRIO_A<out>=<in_1_prio>;...;<in_n_prio>}

### Network Configuration

Operation	See in section	Command
Query the Current IP Status	6.4.1	{IP_STAT=?}
Set the IP Address	6.4.2	{IP_ADDRESS=<type>;IP_ADDRESS}
Set the Subnet Mask	6.4.3	{IP_NETMASK=<subnet_mask>}
Set the Gateway Address	6.4.4	{IP_GATEWAY=<gateway_address>}
Apply Network Settings	6.4.5	{IP_APPLY}

### GPIO Configuration

Operation	See in section	Command
Set Level and Direction for Each Pins	6.5.1	{GPIO<pin_nr>=<dir>;<level>}

# 7

## LW3 Programmer's Reference

The device can be controlled through Lightware 3 (LW3) protocol commands to ensure the compatibility with other Lightware products. The supported LW3 commands are described in this chapter.

- ▶ [OVERVIEW](#)
- ▶ [THE TREE STRUCTURE OF THE TRANSMITTER](#)
- ▶ [LW3 COMMANDS](#)
- ▶ [FORMAL DEFINITIONS](#)
- ▶ [SYSTEM COMMANDS](#)
- ▶ [VIDEO PORT SETTINGS](#)
- ▶ [AUDIO PORT SETTINGS](#)
- ▶ [NETWORK CONFIGURATION](#)
- ▶ [RS-232 PORT CONFIGURATION](#)
- ▶ [SENDING MESSAGE VIA THE COMMUNICATION PORTS](#)
- ▶ [GPIO PORT CONFIGURATION](#)
- ▶ [EDID MANAGEMENT](#)
- ▶ [LW3 COMMANDS - QUICK SUMMARY](#)

### 7.1. Overview

Lightware 3 (LW3) protocol is used by the 25G hybrid matrix, the MODEX family and the new series of Lightware TPS and OPT products, including the HDMI-3D-OPT series extenders. The protocol (LW3) is ASCII-based and all commands are terminated with a carriage return (Cr, '\r') and line feed (Lf, '\n') pair. It is organized as a tree structure that provides outstanding flexibility for implementing a human readable, but programmatically still ease to parse, which is suitable for different products with a different feature list.

In order to implement a flexible, easy-to-use protocol that is straightforward to adapt to new devices and provides outstanding scalability and sustainability, we decided to organize all settings, parameters and properties of the device to a tree structure with 'nodes', 'properties' and 'methods'.

#### 7.1.1. Elements of the Tree Structure

**ATTENTION!** All names and values are case-sensitive. The space character is replaced by the '•' character in the elements and commands descriptions.

##### 7.1.1.1. Node

- The basic building block of the tree structure is the 'node'.
- The node can have multiple child nodes, but only one parent.
- The tree has only one root the 'root node'.
- The leaves of the tree are also nodes, which do not have child nodes.
- The nodes are separated by a slash ('/') character.
- All the slashes are 'right slashes', no backslash is used.
- The identifier of the root node is a slash ('/')
- The node name can contain the elements of the English alphabet and numbers.
- Recommended convention for case sensitivity:
  - Fix nodes (that cannot be altered) are capitalized.
  - User created nodes can contain both lowercase and capital letters, no restrictions.
- The path of a node has to contain all parent nodes from the root node.

**Format:** (the root node): nX●/

**Path:** nX●/[nodeName]/[nodeName]/[nodeName]

**Legend:**

n:	node
'X' can be:	
':':	default for a node.
'm':	this is a manual for the node.
'E':	this is an error message for the node.
's':	this is a symlink node.
'v':	this node has virtual children.
'r':	this is a remote node.

**INFO:** All parent nodes must be listed in the path of a node.

Following example presents the structure of the tree traversal:

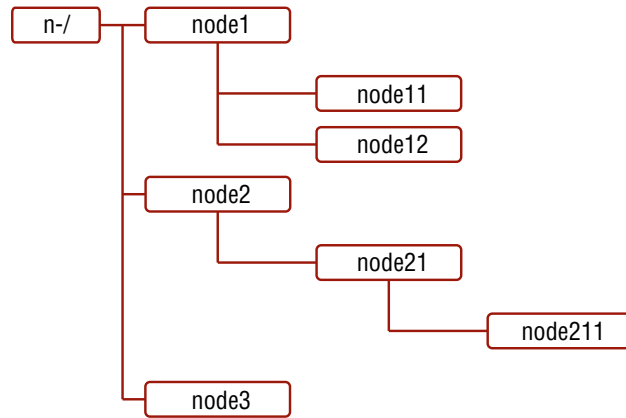

**Tree structure of the nodes**

**Path of the nodes:**

```

n- /node1
n- /node1/node11
n- /node1/node12
n- /node2
n- /node2/node21
n- /node2/node21/node211
n- /node3
  
```

### 7.1.1.2. Property

The 'property' in the LW3 protocol is basically a leaf, which has a well-defined value.

- A property has a value.
- A property cannot have child nodes or child properties. It is always a leaf.
- A node can have any number of properties (may not have any).
- A property is referenced with a dot ('.') after the node name.
- The properties' name can contain the elements of the English alphabet, numbers and underscore ('\_') character.
- By convention, properties are beginning with a capital letter, all other characters are lowercase ones. In the case of compound words, all words are beginning with a capital letter (CamelCase).
- The value of the property can contain any readable ASCII character.
- A property can be read-only or read/write.

**Format:** pX●/[nodeName].[propertyName]=[propertyValue]

**Legend:**

p: property  
 'X' can be:  
 'r': if the property is read-only.  
 'w': if the property is readable, writable.  
 'm': the manual of the property.  
 'E': error message for the property.  
 'v': virtual node property: contains a node path to a node which will be linked to the property's parent node.

**Example:**

The following two ones are read-only properties:

```

pr●/node1/node12.ReadOnlyProperty=value1
pr●/.DeviceName=25G Hybrid Device
  
```

The following two ones are read-write properties:

```

pw●/node1/node12.ReadWriteProperty=value2
pw●/.DeviceNickName=John
  
```

### 7.1.1.3. Method

The 'method' in the LW3 protocol is also a leaf. It cannot have a value, such as the properties, but it can be invoked with a parameter with the help of a special 'CALL' command.

- A method cannot have child nodes or child methods. It is always a leaf.
- A node can have any number of methods (may not have any).
- A method is referenced with a colon (':') after the node.
- The methods' name can contain the elements of the English alphabet, numbers and underscore ('\_') character.
- By convention, methods are beginning with lowercase letter. In case of compound words, the very first letter is lowercase, and the first letter of each other words are capitalized (lowerCamelCase).
- The parameter of the method can contain any readable ASCII character.
- The method always has a return 'state' if the method could be executed. The state could be either 'OK' or 'FAILED'.
- The method does not necessarily have a return 'value'. If it does, it can contain additional information, which is always specific to the current case (the return value can specify why the execution failed).
- When the method cannot be executed (e.g. the parameter list is illegal), there is an error message.

**Format:** mX●/[nodeName]:[methodName]=[returnValue]

**Legend:**

m: method  
 'X' can be:  
 'O': when the execution of the method was successful (OK).  
 'F': when the execution of the method failed.  
 'm': the manual of the method.  
 'E': error message for the method.

**Example:**

```

mO●/node1/node12:method1
mO●/MEDIA/VIDEO/XP:switch
mE●%E001:Syntax error
mm●/MEDIA/VIDEO/XP:lockSource:Lock one or more source ports
  
```

### 7.1.2. Escaping

Property values and method parameters can contain characters that are used as control characters in the protocol. They must be escaped. The escape character is the backslash ('\') and escaping means injecting a backslash before the character that should be escaped (like in C language).

Control characters are the followings: \ { } # % ( ) \r \n \t

#### Example:

The original text: John•(Doe).•#3:•5%2=1•node1\node11

The escaped text: John•\ (Doe\).•\#3:•5\%2=1•node1\\node11

### 7.1.3. Error Messages

There are several error messages defined in the LW3 protocol, all of them have a unique error number.

**Format:** XE•[primitive]•%EYYY:•[Error message]

#### Legend:

'X' can be:

'-': syntax error. Cannot parse the command at all.

'n': node error.

'p': property error.

'm': method error.

YYY: error code, which can be one of the followings:

YYY: error code	Name	Default text
000	Lw3ErrorCodes_None	
001	Lw3ErrorCodes_Syntax	Syntax error
002	Lw3ErrorCodes_NotFound	Not found
003	Lw3ErrorCodes_AlreadyExists	Already exists
004	Lw3ErrorCodes_InvalidValue	Invalid value
005	Lw3ErrorCodes_IllegalParamCount	Illegal parameter count
006	Lw3ErrorCodes_IllegalOperation	Illegal operation
007	Lw3ErrorCodes_AccessDenied	Access denied
008	Lw3ErrorCodes_Timeout	Timeout
009	Lw3ErrorCodes_CommandTooLong	Command too long
010	Lw3ErrorCodes_InternalError	Internal error
011	Lw3ErrorCodes_NotImplemented	Not implemented

### 7.1.4. Prefix Summary

The following prefixes are defined in the LW3 protocol:

'n-': a node,

'nE': an error for a node,

'nm': a manual for a node,

'pr': a read-only property,

'pw': read-write property,

'pE': an error for the property,

'pm': a manual for the property,

'm-': a method,

'mO': a response after a success method execution,

'mF': a response after a failed method execution,

'mE': an error for a method,

'mm': a manual for a method.

## 7.2. The Tree Structure of the Transmitter

INFO: The tree structure is available in the [Advanced View Window](#) of LDC.

The /MEDIA node is used by the LDC to connect input ports to output ports on different layers. Each subnode of /MEDIA is representing a layer, e.g. video (/MEDIA/VIDEO), audio (/MEDIA/AUDIO) or RS-232 (/MEDIA/UART). Each layer has a crosspoint to define connections between the ports associated with the layer, all of them are represented by a specific node. E.g. the video layer node is /MEDIA/VIDEO: under the video layer node, the video crosspoint node (XP) and the video ports (I1, I2, ...) are located.

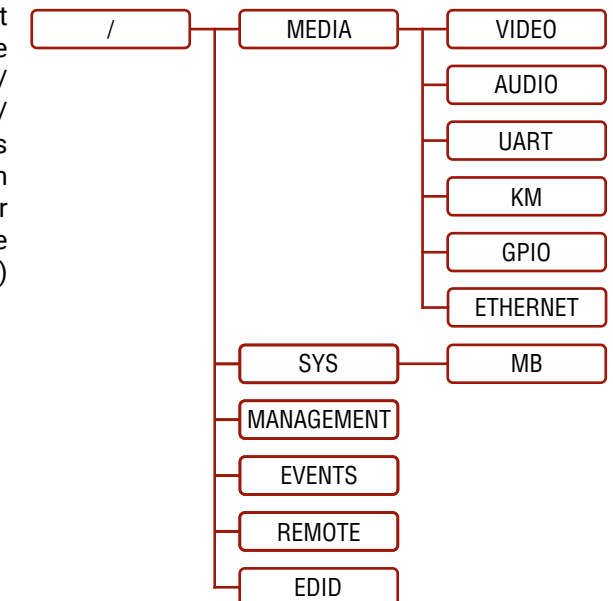

## 7.3. LW3 Commands

### 7.3.1. Get Command

The 'GET' command can be used to get the child nodes, properties and methods of a specific node. It can also be used to get the value of a property.

#### The Response Format

The first two characters of a response unambiguously identify the type of the element that the response line concerns. The first character is the type of the element (node, property or method), the second is for miscellaneous information (e.g. read/write rights).

The defined prefixes are:

'n':	node
'pr':	property - only readable
'pw':	property - writable, readable
'm':	method executable

After the prefix, the response contains the full path of the node, property or method after a space character.

#### Get All Children of a Node

Get all of the child nodes of a parent node, with one GET command.

**Command format:** GET●[nodePath]

**Response format:** n-●[nodePath]

**Example:**

```
> GET /MEDIA
< n- /MEDIA/VIDEO
< n- /MEDIA/AUDIO
< n- /MEDIA/UART
< n- /MEDIA/KM
< n- /MEDIA/GPIO
< n- /MEDIA/ETHERNET
```

#### Get All Properties and Methods of a Node

Get all properties and methods of a node, with one GET command and asterisk character.

**Command format:** GET●[nodePath].\*

**Response format:** (for properties)

pX●[nodePath].[propertyName]=[parameter]

**Legend:**

X can be:	
'r':	read-only
'w':	read-write

**Response format:** (for methods)

m-●[nodePath]:[methodName]

**Example:**

```
> GET /EDID.*
< pr /EDID.EdidStatus=D1:E1;D1:E2;D1:E3;D1:E4
< m- /EDID:switch
< m- /EDID:switchAll
< m- /EDID:copy
< m- /EDID:delete
< m- /EDID:reset
```

#### Get All Child Nodes, Properties and Methods of a Node

Get all child nodes, properties and methods of a node with one command, without using a wild card.

**Command format:** GETALL●[nodePath]

**Response format:** (for nodes)

n-●[nodePath]

**Response format:** (for properties)

pX●[nodePath].[propertyName]=[parameter]

**Legend:**

X can be:	
'r':	read-only
'w':	read-write

**Response format:** (for methods)

m-●[nodePath]:[methodName]

**Example:**

```
> GETALL /EDID
< n- /EDID/F
< n- /EDID/D
< n- /EDID/U
< n- /EDID/E
< pr /EDID.EdidStatus=D1:E1;D1:E2;D1:E3;D1:E4
< m- /EDID:switch
< m- /EDID:switchAll
< m- /EDID:copy
< m- /EDID:delete
< m- /EDID:reset
```

**7.3.2. Set Command**

The setter command can be used to modify the value of a property.

**Command format:** SET●[nodePath].[propertyName]=[newPropertyValue]

**Response format:**

The response for setting a property to a new value is the same as the response for the 'GET' command. The value in the response is the new value if the execution of the 'SET' command was successful, otherwise the unmodified 'old value' with an error message.

pw●[nodePath].[propertyName]=[newPropertyValue]

**Example:**

```
> SET /SYS/MB/RS232/LOCAL.Rs232Mode=1
< pw /SYS/MB/RS232/LOCAL.Rs232Mode=1
```

**Error response format:**

If there were errors during setting a property, an error message follows the unmodified property value.

pE●[nodePath].[propertyName]=[unmodifiedValue]●%EXXX:Error message

**Legend:** XXX: error number.

**Examples:**

```
> SET /SYS/MB/RS232/LOCAL.Rs232Mode=11
< pE /SYS/MB/RS232/LOCAL.Rs232Mode %E005:Invalid value
```

```
> SET /SYS/MB/RS232/LOCAL.ActiveProtocol=LW3
< pE %E004:Writing read-only property
```

**7.3.3. Invocation**

A method can be invoked with the help of the 'CALL' command.

**Command format:** CALL●[nodePath]:[methodName]([parameter])

**Response format:**

The response for a method execution is a state and a value. The state is mandatory and always defined if the method could be executed. It can be either a success or a failure. The value is optional and it can contain additional information, such as the reason why the state is a failure or a specific value when the state is success that the client can process. It is also possible to get an error message when the method could not be executed – e.g. the parameter was illegal - and hence not even the state of the execution could be specified.

mX●[nodePath]:[methodName]=Y

**Legend:**

X can be:

'O': if the execution is successful.  
 'F': if the execution is failed, but the method could be executed.  
 'E': if the method could not be executed: e.g. illegal parameter count.

Y can be:

- The return value of the method if any.
- It is valid that a method does not have any return value. In this case, the equal sign ('=') can be omitted.

**Example:**

```
> CALL /EDID:switch(D1:E1)
< mO /EDID:switch
```

**Error response format:**

If there were errors during the execution, an error message is received, which follows the method name.

mE●[nodePath]:[methodName]●%EXXX:Error message

**Example:**

```
> CALL /EDID:switch(D1:R1)
< mE %E001:Syntax error
```

### 7.3.4. Manual

For every node, property and method in the tree there is a manual. The manual is a human readable text that describes the syntax and provides a hint for how to use the primitives.

#### Command format:

for nodes:           MAN●[nodePath]  
for property:        MAN●[nodePath].[propertyName]  
for method:         MAN●[nodePath]:[methodName]

#### Response format:

The human readable manual is separated by a space ( ' ') character from the primitives.

for nodes:           nm●[nodePath]●Human readable manual  
for property:        pm●[nodePath].[propertyName]●Human readable manual  
for method:         mm●[nodePath]:[methodName]●Human readable manual

**Example:** (for a property)

```
> MAN /SYS/MB/RS232/LOCAL.ActiveProtocol
< pm /SYS/MB/RS232/LOCAL.ActiveProtocol ["LW2" | "LW3"] Active Protocol
```

**Example:** (for a method)

```
> MAN /SYS/MB/RS232/LOCAL:factoryDefaults
< mm /SYS/MB/RS232/LOCAL:factoryDefaults [] Restore factory default settings
```

### 7.3.5. Signature

For some command, the response can contain multiple lines. Each line is terminated with a carriage return (Cr, '\r') and line feed (Lf, '\n') characters. In several cases the number of the lines in the response cannot be determined in advance, e.g. the client is intended waiting for the whole response and also wants to be sure, that the received lines belong together and to the same command. In these cases, a special feature the 'signature' can be used.

The signature is a four digit long hexadecimal value that can be optionally placed before every command. In that case, the response to that particular command will also be preceded by the signature, and the corresponding lines will be between brackets.

**Command format:**   XXXX#[command]

**Legend:**        xxxx: 4-digit long hexadecimal value.

#### Response format:

```
{XXXX
[command lines]
}
```

#### Example:

```
> 1103#GET /MEDIA/UART.*
< {1103
< pr /MEDIA/UART.PortCount=1
< pr /MEDIA/UART.PortUI=P1:12209
< pr /MEDIA/UART.P1=Local
< }
```

INFO: The lines of the signature are also Cr and Lf terminated.

### 7.3.6. Subscription

A user can subscribe to any node. Subscribe to a node means that the user will get a notification if any of the properties of the node is changed. These notifications are asynchronous messages - such as the ones described above - and hence, they are useful to keep the client application up-to-date, without receiving any unwanted information. When the user does not want to be informed about the changes anymore, he can simply unsubscribe from the node.

**ATTENTION!** The subscriptions are handled separately for connections. Hence, if the connection is terminated all registered subscriptions are deleted. After closing a connection the subscribe command has to be sent in order to get the notifications of the changes on that connection.

#### Subscribe to a Node

**Command format:**   OPEN●[nodePath]

**Response format:**  o-●[nodePath]

#### Example:

```
> OPEN /MEDIA/VIDEO
< o- /MEDIA/VIDEO
```

#### Subscribe to Multiple Nodes

In order to subscribe to multiple nodes, the asterisk wild card can be used.

**Command format:**   OPEN●[nodePath]/\*

**Response format:**  o-●[nodePath]/\*

#### Example:

```
> OPEN /MEDIA/VIDEO/*
< o- /MEDIA/VIDEO/*
```

### Get the Active Subscriptions for the Current Connection

**Command format:** OPEN

**Response format:** o-●[nodePath]

**Example:**

```
> OPEN
< o- /MEDIA/VIDEO
< o- /EDID
< o- /LOG
```

### Unsubscribe from a Node

**Command format:** CLOSE●[nodePath]

**Response format:** c-●[nodePath]

**Example:**

```
> CLOSE /MEDIA/VIDEO
< c- /MEDIA/VIDEO
```

### Unsubscribe from Multiple Nodes

**Command format:** CLOSE●[nodePath]/\*

**Response format:** c-●[nodePath]/\*

**Example:**

```
> CLOSE /MEDIA/VIDEO/*
< c- /MEDIA/VIDEO/*
```

### 7.3.7. Notifications about the Changes of the Properties

When the value of a property is changed and the user is subscribed to the node, which the property belongs to, an asynchronous notification is generated. This notification is called as the 'change message'. The format of such a message is very similar to the response for the 'GET' command.

**Format:** CHG●[nodePath].[propertyName]=[newPropertyValue]

**Example:**

```
< CHG /EDID.EdidStatus=D1:E1;D1:E2;D1:E3;D1:E4
```

### A Short Example of How to Use the Subscription

In the following, an example is presented, how the subscriptions are working and how to use them. In the example, there are two independent users controlling the device through two independent connections ('Connection #1' and 'Connection #2'). The events in the rows occur after each other.

```

Connection #1 > OPEN /MEDIA/VIDEO/XP
               < o- /MEDIA/VIDEO/XP
               > GET /MEDIA/VIDEO/XP.DestinationConnectionList
               < pr /MEDIA/VIDEO/XP.DestinationConnectionList=I1

Connection #2 > GET /MEDIA/VIDEO/XP.DestinationConnectionList
               < pr /MEDIA/VIDEO/XP.DestinationConnectionList=I1
               > CALL /MEDIA/VIDEO/XP:switch(I1:O1)
               < mO /MEDIA/VIDEO/XP:switch

Connection #1 < CHG /MEDIA/VIDEO/XP.DestinationConnectionList=I1

```

**Explanation:** The first user (Connection #1) set a subscription to a node. Later the other user (Connection #2) made a change, and thanks for the subscription, the first user got a notification about the change.

## 7.4. Formal Definitions

Method parameters and property values are specified in a modified version of Backus Naur Form (BNF). The syntax is the following:

"literal"	literals are quoted
<expression1> <expression2>	vertical bars denote alternatives
[<expression>]	expressions in square brackets are optional
<number>*<expression>	expression is repeated at least <number> times
*[<expression>]	<number> may be omitted, in this case number defaults to 0
<number>*<expression>	expressions in curly brackets are repeated exactly <number> times
In	Input port number
Om	Output port number



## 7.5. System Commands

### 7.5.1. Query the Product Name

The name of the product is a read-only parameter and cannot be modified.

**Command format:** GET●/.ProductName

**Response format:** pr●/.ProductName=<Product\_name>

**Example:**

```
> GET /.ProductName
< pr /.ProductName=SW4-OPT-TX240RAK
```

### 7.5.2. Set the Device Label

**ATTENTION!** The device label can be changed to a custom text in the [Status](#) tab of the LDC software. This writable parameter is not the same as the ProductName parameter.

**Command format:** SET●/MANAGEMENT/UID/DeviceLabel=<Custom\_name>

**Response format:** pw●/MANAGEMENT/UID/DeviceLabel=<Custom\_name>

The Device Label can be 39 character length and ASCII characters are allowed. Longer names are truncated.

**Example:**

```
> SET /MANAGEMENT/UID.DeviceLabel=SW4-OPT_Control_room
< pw /MANAGEMENT/UID.DeviceLabel=SW4-OPT_Control_room
```

### 7.5.3. Query the Serial Number

**Command format:** GET●/.SerialNumber

**Response format:** pr●/.SerialNumber=<serial\_nr>

**Example:**

```
> GET /.SerialNumber
< pr /.SerialNumber=87654321
```

### 7.5.4. Query the Firmware Version

**Command format:** GET●/SYS/MB.FirmwareVersion

**Response format:** pr●/SYS/MB.FirmwareVersion=<firmware\_version>

```
> GET /SYS/MB.FirmwareVersion
< pr /SYS/MB.FirmwareVersion=1.1.0b5 r8
```

### 7.5.5. Resetting the Device

The transmitter can be restarted – the current connections (LAN, RS-232) will be terminated.

**Command format:** CALL●/SYS:reset()

**Response format:** mO●/SYS:reset=

**Example:**

```
> CALL /SYS:reset()
< mO /SYS:reset=
```

### 7.5.6. Restore the Factory Default Settings

**Command format:** CALL●/SYS:factoryDefaults()

**Response format:** mO●/SYS:factoryDefaults=

**Example:**

```
> CALL /SYS:factoryDefaults()
< mO /SYS:factoryDefaults=
```

The device is restarted, current connections are terminated, and the default settings are restored. See the complete list in the [Factory Default Settings](#) section.

## 7.6. Video Port Settings

INFO: Video port numbering can be found in the [Input/Output Port Numbering](#) section.

### 7.6.1. Query the Status of Source Ports

**Command format:** GET●/MEDIA/VIDEO/XP.SourcePortStatus

**Response format:** pr●/MEDIA/VIDEO/XP.SourcePortStatus=[<I<sub>1</sub>>;<I<sub>2</sub>>;...;<I<sub>n</sub>>]

The response contains 5 ASCII characters for each port. The first character indicates the mute/lock state, the next four characters represent a 2-byte HEX code showing the current state of the input ports.

**Example:**

```
> GET /MEDIA/VIDEO/XP.SourcePortStatus
< pr /MEDIA/VIDEO/XP.SourcePortStatus=T00FF;T00EF;T00AA;T00FF
```

**Legend:**

Letter (Character 1)		
	Mute state	Lock state
T	Unmuted	Unlocked
L	Unmuted	Locked
M	Muted	Unlocked
U	Muted	Locked

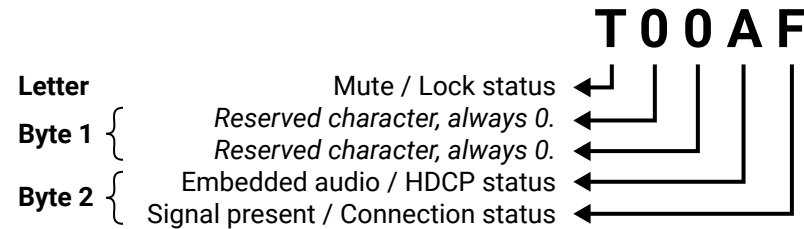

	Byte 1				Byte 2			
	Character 2		Character 3		Character 4		Character 5	
	BIT 7-6	BIT 5-4	BIT 3-2	BIT 1-0	BIT 7-6	BIT 5-4	BIT 3-2	BIT 1-0
	Reserved	Reserved	Reserved	Reserved	Embedded audio status	HDCP status	Signal present status	Connection status
00					Unknown			
01					Reserved			
10	Reserved	Reserved	Reserved	Reserved	No embedded audio	Not encrypted	No signal	Not connected
11					Embedded audio presents	Encrypted	Signal presents	Connected

**Example and Explanation (for input 2, T00EF):**

T	O		O		E		F	
Unlocked, Unmuted	00	00	00	00	11	10	11	11
	Reserved	Reserved	Reserved	Reserved	Embedded audio presents	Not encrypted	Signal presents	Connected

### The Most Common Received Port Status Responses

T00AA	T	O		O		A		A	
	Unlocked, Unmuted	00	00	00	00	10	10	10	10
	Reserved	Reserved	Reserved	Reserved	No embedded audio	Not encrypted	No signal	Not connected	

T00AB	T	O		O		A		B	
	Unlocked, Unmuted	00	00	00	00	10	10	10	11
	Reserved	Reserved	Reserved	Reserved	No embedded audio	Not encrypted	No signal	Connected	

T00AF	T	O		O		A		F	
	Unlocked, Unmuted	00	00	00	00	10	10	11	11
	Reserved	Reserved	Reserved	Reserved	No embedded audio	Not encrypted	Signal presents	Connected	

T00EF	T	O		O		E		F	
	Unlocked, Unmuted	00	00	00	00	11	10	11	11
	Reserved	Reserved	Reserved	Reserved	Embedded audio presents	Not encrypted	Signal presents	Connected	

T00BF	T	O		O		B		F	
	Unlocked, Unmuted	00	00	00	00	10	11	11	11
	Reserved	Reserved	Reserved	Reserved	No embedded audio	Encrypted	Signal presents	Connected	

T00FF	T	O		O		F		F	
	Unlocked, Unmuted	00	00	00	00	11	11	11	11
	Reserved	Reserved	Reserved	Reserved	Embedded audio presents	Encrypted	Signal presents	Connected	

### 7.6.2. Query the Status of Destination Port

**Command format:** GET●/MEDIA/VIDEO/XP.DestinationPortStatus

**Response format:** pr●/MEDIA/VIDEO/XP.DestinationPortStatus=[<O<sub>n</sub>>]

The response contains 5 ASCII characters for each port. The first character indicates the mute/lock state, the next 2-byte long HEX code showing the current state of the output ports.

**Example:**

```
> GET /MEDIA/VIDEO/XP.DestinationPortStatus
< pr /MEDIA/VIDEO/XP.DestinationPortStatus=M00BF;T00EF
```

**Legend:** See at previous section.

**Example and Explanation (for output 1, M00BF):**

M	0		0		B		F	
Unlocked, Muted	00	00	00	00	10	11	11	11
	Reserved	Reserved	Reserved	Reserved	No embedded audio	Encrypted	Signal presents	Connected

### 7.6.3. Query the Video Crosspoint Setting

**Command format:** GET●/MEDIA/VIDEO/XP.DestinationConnectionList

**Response format:** pr●/MEDIA/VIDEO/XP.DestinationConnectionList=<I<sub>n</sub>>

**Legend:**

<I<sub>n</sub>>: Video input port number

**Example:**

```
> GET /MEDIA/VIDEO/XP.DestinationConnectionList
< pr /MEDIA/VIDEO/XP.DestinationConnectionList=I1
```

**Explanation:** I1 input port is connected to the output port.

### 7.6.4. Switching Video Input

**Command format:** CALL●/MEDIA/VIDEO/XP:switch(<I<sub>n</sub>>:<O<sub>m</sub>>)

**Response format:** mO●/MEDIA/VIDEO/XP:switch

**Example:**

```
> CALL /MEDIA/VIDEO/XP:switch(I2:O1)
< mO /MEDIA/VIDEO/XP:switch
```

**Explanation:** I2 port is connected to O1 port.

### 7.6.5. Query the Video Autoselect Settings

**Command format:** GET●/MEDIA/VIDEO/XP.DestinationPortAutoselect

**Response format:** pr●/MEDIA/VIDEO/XP.DestinationPortAutoselect=<O<sub>n</sub>\_set>

The response shows the settings of each output one by one.

**Legend:**

<O<sub>n</sub>\_set> Two-letter code of the Autoselect settings:

Letter	Explanation	
1 <sup>st</sup> letter	E:	Autoselect is <b>enabled</b> .
	D:	Autoselect is <b>disabled</b> .
2 <sup>nd</sup> letter	F:	<b>First</b> detect mode: the first active video input is selected.
	P:	<b>Priority</b> detect mode: always the highest priority active video input will be selected.
	L:	<b>Last</b> detect mode: always the last attached input is switched to the output automatically.

**Example:**

```
> GET /MEDIA/VIDEO/XP.DestinationPortAutoselect
< pr /MEDIA/VIDEO/XP.DestinationPortAutoselect=EL
```

**Explanation:**

EL: the Autoselect is Enabled on output, selected mode is Last detect.

INFO: For more information about the Autoselect feature see [The Autoselect Feature](#) section.

### 7.6.6. Change the Autoselect Mode

**Command format:** CALL●/MEDIA/VIDEO/XP:setDestinationPortAutoselect(<O<sub>n</sub>>:<O<sub>n</sub>\_set>)

**Response format:** mO●/MEDIA/VIDEO/XP:setDestinationPortAutoselect

**Legend:** see previous section.

**Example1:**

```
> CALL /MEDIA/VIDEO/XP:setDestinationPortAutoselect(O1:EPM)
< mO /MEDIA/VIDEO/XP:setDestinationPortAutoselect
```

**Explanation1:** The setting is changed to "EPM": Autoselect is enabled (E); the mode is set to "priority detect" (P), and the port will be disconnected if a higher priority port becomes active (M).

**Example2:**

```
> CALL /MEDIA/VIDEO/XP:setDestinationPortAutoselect(O1:D)
< mO /MEDIA/VIDEO/XP:setDestinationPortAutoselect
```

**Explanation2:** The setting is changed to "DPM": Autoselect is disabled (D). The other settings remain unchanged. Since the outputs are linked, the change will affect local and link out.

### 7.6.7. Query the Input Port Priority

**Command format:** GET●/MEDIA/VIDEO/XP.PortPriorityList

**Response format:** pr●/MEDIA/VIDEO/XP.PortPriorityList=<O<sub>n</sub>\_list>

The response shows the priority of each output one after another. The priority number can be from 0 to 31; 0 is the highest- and 30 is the lowest priority. 31 means that the port will be skipped from the priority list.

**Legend:**

<O<sub>n</sub>\_list>      The input port priority order of the given output port: <l<sub>1</sub>>,<l<sub>2</sub>>,...,<l<sub>m</sub>>

**Example:**

```
> GET /MEDIA/VIDEO/XP.PortPriorityList
< pr /MEDIA/VIDEO/XP.PortPriorityList=0,1,2,3,4,5
```

**Explanation:**

Priority	0	1	...	x
Video input port	l1	l2	...	l <sub>m</sub>

Highest priority is assigned to l1 port.

**ATTENTION!** The same priority number can be set to different input ports. When the priority numbers match, the input port with the lowest port number will have the highest priority.

### 7.6.8. Change the Input Port Priority

**Command format:** CALL●/MEDIA/VIDEO/XP:setAutoselectionPriority(<l<sub>n</sub>>(<O<sub>m</sub>>):<prio>)

**Response format:** mO●/MEDIA/VIDEO/XP:setAutoselectionPriority

**Legend:**

<prio>:      Priority number from 0 to 31, equal numbers are allowed (31 means that the port will be skipped from the priority list).

An input port priority can be set on an output port. Many settings can be executed by separating a semicolon (no space), see the example below.

**Example:**

```
> CALL /MEDIA/VIDEO/XP:setAutoselectionPriority(I1\ (01\):3;I2\ (01\):3)
< mO /MEDIA/VIDEO/XP:setAutoselectionPriority
```

**Explanation:**

The priority number of input 1 and Input 2 has been set to 3 on output 1. The example shows that certain control characters have been escaped: the backslash “\” character is inserted before the “(” and “)” characters. See more information about the escaping in the [Escaping](#) section.

### 7.6.9. Mute an Input Port

**Command format:** CALL●/MEDIA/VIDEO/XP:muteSource(<l<sub>n</sub>>)

**Response format:** mO●/MEDIA/VIDEO/XP:muteSource

**Example:**

```
> CALL /MEDIA/VIDEO/XP:muteSource(I1)
< mO /MEDIA/VIDEO/XP:muteSource
```

### 7.6.10. Unmute an Input Port

**Command format:** CALL●/MEDIA/VIDEO/XP:unmuteSource(<l<sub>n</sub>>)

**Response format:** mO●/MEDIA/VIDEO/XP:unmuteSource

**Example:**

```
> CALL /MEDIA/VIDEO/XP:unmuteSource(I1)
< mO /MEDIA/VIDEO/XP:unmuteSource
```

### 7.6.11. Lock an Input Port

**Command format:** CALL●/MEDIA/VIDEO/XP:lockSource(<l<sub>n</sub>>)

**Response format:** mO●/MEDIA/VIDEO/XP:lockSource

**Example:**

```
> CALL /MEDIA/VIDEO/XP:lockSource(I1)
< mO /MEDIA/VIDEO/XP:lockSource
```

### 7.6.12. Unlock an Input Port

**Command format:** CALL●/MEDIA/VIDEO/XP:unlockSource(<l<sub>n</sub>>)

**Response format:** mO●/MEDIA/VIDEO/XP:unlockSource

**Example:**

```
> CALL /MEDIA/VIDEO/XP:unlockSource(I1)
< mO /MEDIA/VIDEO/XP:unlockSource
```

### 7.6.13. Mute Output

**Command format:** CALL●/MEDIA/VIDEO/XP:muteDestination(<O<sub>n</sub>>)

**Response format:** mO●/MEDIA/VIDEO/XP:muteDestination

**Example:**

```
> CALL /MEDIA/VIDEO/XP:muteDestination(01)
< mO /MEDIA/VIDEO/XP:muteDestination
```

#### 7.6.14. Unmute Output

**Command format:** CALL●/MEDIA/VIDEO/XP:unmuteDestination(<O<sub>n</sub>>)

**Response format:** mO●/MEDIA/VIDEO/XP:unmuteDestination

**Example:**

```
> CALL /MEDIA/VIDEO/XP:unmuteDestination(01)
< m0 /MEDIA/VIDEO/XP:unmuteDestination
```

#### 7.6.15. Lock Output

**Command format:** CALL●/MEDIA/VIDEO/XP:lockDestination(<O<sub>n</sub>>)

**Response format:** mO●/MEDIA/VIDEO/XP:lockDestination

**Example:**

```
> CALL /MEDIA/VIDEO/XP:lockDestination(01)
< m0 /MEDIA/VIDEO/XP:lockDestination
```

#### 7.6.16. Unlock Output

**Command format:** CALL●/MEDIA/VIDEO/XP:unlockDestination(<O<sub>n</sub>>)

**Response format:** mO●/MEDIA/VIDEO/XP:unlockDestination

**Example:**

```
> CALL /MEDIA/VIDEO/XP:unlockDestination(01)
< m0 /MEDIA/VIDEO/XP:unlockDestination
```

#### 7.6.17. HDCP Setting (Input Port)

HDCP capability can be enabled/disabled on the input ports, thus, non-encrypted content can be seen on a non-HDCP compliant display. See more information in the [HDCP Management](#) section.

**Command format:** SET●/MEDIA/VIDEO/<I<sub>n</sub>>.HdcpEnable=true|false

**Response format:** pw●/MEDIA/VIDEO/<I<sub>n</sub>>.HdcpEnable=true|false

**Example:**

```
> SET /MEDIA/VIDEO/I2.HdcpEnable=true
< pw /MEDIA/VIDEO/I2.HdcpEnable=true
```

#### 7.6.18. HDCP Setting (Output Port)

HDCP capability can be set to Auto/Always on the output ports, thus, non-encrypted content can be transmitted to a non-HDCP compliant display. See more information in the [HDCP Management](#) section.

**Command format:** SET●/MEDIA/VIDEO/<O<sub>n</sub>>.HdcpModeSetting=0|1

**Response format:** pw●/MEDIA/VIDEO/<O<sub>n</sub>>.HdcpModeSetting=0|1

**Parameters:**

.HdcpModeSetting	0	1
HDCP mode	Auto	Always

**Example:**

```
> SET /MEDIA/VIDEO/01.HdcpModeSetting=0
< pw /MEDIA/VIDEO/01.HdcpModeSetting=0
```

#### 7.6.19. Test Pattern Generator

The output ports can send a special image towards the sink devices for testing purposes. The setting is available on output ports with the below-listed parameters.

**ATTENTION!** The Mode can be set individually on each port, but the Clock source and the Pattern settings are common on the optical and HDMI output ports (O1 and O2).

**Test Pattern Generator Mode Setting:**

**Command format:** SET●/MEDIA/VIDEO/<O<sub>n</sub>>.TpgMode=0|1|2

**Response format:** pw●/MEDIA/VIDEO/<O<sub>n</sub>>.TpgMode=0|1|2

**Parameters:**

.TpgMode	0	1	2
Test pattern generator mode	<b>Disabled</b> The test pattern is not displayed on the output	<b>Enabled</b> The test pattern is displayed on the output	<b>No signal mode</b> The test pattern is displayed if there is no signal on the output port

**Example:**

```
> SET /MEDIA/VIDEO/01.TpgMode=2
< pw /MEDIA/VIDEO/01.TpgMode=2
```

**Clock Source – The Clock Frequency of the Test Pattern**

**Command format:** SET●/MEDIA/VIDEO/<O<sub>n</sub>>.TpgClockSource=480|576|EXT

**Response format:** pw●/MEDIA/VIDEO/<O<sub>n</sub>>.TpgClockSource=480|576|EXT

**Parameters:**

.TpgClockSource	480	576	EXT
Clock frequency	480p	576p	External clock (from actual TMDS source)

**Example:**

```
> SET /MEDIA/VIDEO/01.TpgClockSource=576
< pw /MEDIA/VIDEO/01.TpgClockSource=576
```

**Test Pattern**

**Command format:** SET●/MEDIA/VIDEO/<O<sub>n</sub>>.TpgPattern=<pattern>

**Response format:** pw●/MEDIA/VIDEO/<O<sub>n</sub>>.TpgPattern=<pattern>

**Parameters:**

<pattern>	RED	GREEN	BLUE	BLACK	WHITE	RAMP	CHESS	BAR	CYCLE
-----------	-----	-------	------	-------	-------	------	-------	-----	-------

Cycle setting means all the patterns are changed sequentially approx. in every 2 seconds.

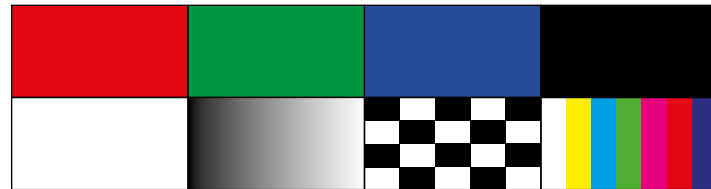

**Example:**

```
> SET /MEDIA/VIDEO/01.TpgPattern=GREEN
< pw /MEDIA/VIDEO/01.TpgPattern=GREEN
```

**7.6.20. HDMI Mode Settings (Output Port)**

**Command format:** SET●/MEDIA/VIDEO/<O<sub>n</sub>>.HdmiModeSetting=0|1|2

**Response format:** pw●/MEDIA/VIDEO/<O<sub>n</sub>>.HdmiModeSetting=0|1|2

**Parameters:**

.HdmiModeSetting	0	1	2
HDMI mode	Auto	DVI	HDMI

**Example:**

```
> SET /MEDIA/VIDEO/01.HdmiModeSetting=2
< pw / MEDIA/VIDEO/01.HdmiModeSetting=2
```

### 7.7. Audio Port Settings

INFO: Audio port numbering can be found in the [Input/Output Port Numbering](#) section.

#### 7.7.1. Query the Status of Source Ports

**Command format:** GET●/MEDIA/AUDIO/XP.SourcePortStatus

**Response format:** pr●/MEDIA/AUDIO/XP.SourcePortStatus=[<I<sub>1</sub>>;<I<sub>2</sub>>;...;<I<sub>n</sub>>]

The response contains 5 ASCII characters for each port. The first character indicates the mute/lock state, the next four characters represent a 2-byte HEX code showing the current state of the input ports.

**Example:**

```
> GET /MEDIA/AUDIO/XP.SourcePortStatus
< pr /MEDIA/AUDIO/XP.SourcePortStatus=T000F;M000B;T000A;T000A;T000F;T000F
```

**Legend:**

Letter (Character 1)		
	Mute state	Lock state
T	Unmuted	Unlocked
L	Unmuted	Locked
M	Muted	Unlocked
U	Muted	Locked

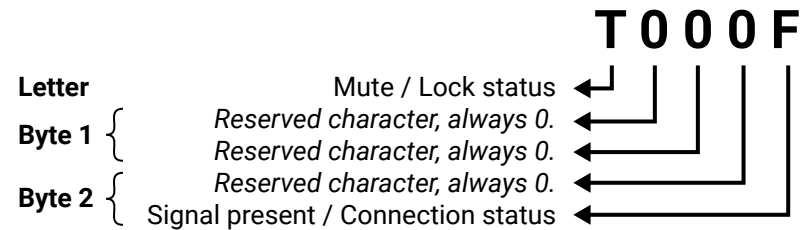

	Byte 1				Byte 2			
	Character 2		Character 3		Character 4		Character 5	
	BIT 7-6	BIT 5-4	BIT 3-2	BIT 1-0	BIT 7-6	BIT 5-4	BIT 3-2	BIT 1-0
	Reserved	Reserved	Reserved	Reserved	Reserved	Reserved	Signal present status	Connection status
00	Reserved	Reserved	Reserved	Reserved	Reserved	Reserved	Unknown	
01							Reserved	
10							No signal	Not connected
11							Signal presents	Connected

**Example and Explanation (for input 2, M000B):**

M	0		0		0		B	
Unlocked, Muted	00	00	00	00	00	00	10	11
	Reserved	Reserved	Reserved	Reserved	Reserved	Reserved	No signal	Connected

#### The Most Common Received Port Status Responses

T000A	T	0		0		0		A	
	Unlocked, Unmuted	00	00	00	00	00	00	00	10
	Reserved	Reserved	Reserved	Reserved	Reserved	Reserved	Reserved	No signal	Not connected

T000B	T	0		0		0		B	
	Unlocked, Unmuted	00	00	00	00	00	00	00	10
	Reserved	Reserved	Reserved	Reserved	Reserved	Reserved	Reserved	No signal	Connected

T000F	T	0		0		0		F	
	Unlocked, Unmuted	00	00	00	00	00	00	00	11
	Reserved	Reserved	Reserved	Reserved	Reserved	Reserved	Reserved	Signal presents	Connected

**Only for Phoenix audio port:** Character 5 is C (11 00) which means signal is present but the cable connection status is unknown. The explanation is Phoenix connector has no pin which can indicate the connection status so this is always unknown.

T000C	T	0		0		0		C	
	Unlocked, Unmuted	00	00	00	00	00	00	00	11
	Reserved	Reserved	Reserved	Reserved	Reserved	Reserved	Reserved	Signal presents	Unknown

#### 7.7.2. Query the Status of Destination Port

**Command format:** GET●/MEDIA/AUDIO/XP.DestinationPortStatus

**Response format:** pr●/MEDIA/AUDIO/XP.DestinationPortStatus=[<O<sub>n</sub>>]

The response contains 5 ASCII characters for each port. The first character indicates the mute/lock state, the next 2-byte long HEX code showing the current state of the output ports.

**Example:**

```
> GET /MEDIA/AUDIO/XP.DestinationPortStatus
< pr /MEDIA/AUDIO/XP.DestinationPortStatus=T000F;T000A
```

**Legend:** See at previous section.

**Example and Explanation (for output 1, T000F):**

T	0		0		0		F	
Unlocked, Unmuted	00	00	00	00	00	00	11	11
	Reserved	Reserved	Reserved	Reserved	Reserved	Reserved	Signal presents	Connected

### 7.7.3. Query the Audio Crosspoint Setting

**Command format:** GET●/MEDIA/AUDIO/XP.DestinationConnectionList

**Response format:** pr●/MEDIA/AUDIO/XP.DestinationConnectionList=<I<sub>n</sub>>

**Legend:**

<I<sub>n</sub>>: Audio input port number

**Example:**

```
> GET /MEDIA/AUDIO/XP.DestinationConnectionList
< pr /MEDIA/AUDIO/XP.DestinationConnectionList=I1
```

**Explanation:** I1 input port is connected to the output port.

### 7.7.4. Switching Audio Input

**Command format:** CALL●/MEDIA/AUDIO/XP:switch(<I<sub>n</sub>>:<O<sub>m</sub>>)

**Response format:** mO●/MEDIA/AUDIO/XP:switch

**Example:**

```
> CALL /MEDIA/AUDIO/XP:switch(I2:O1)
< mO /MEDIA/AUDIO/XP:switch
```

**Explanation:** I2 port is connected to O1 port.

### 7.7.5. Query the Audio Autoselect Settings

**Command format:** GET●/MEDIA/AUDIO/XP.DestinationPortAutoselect

**Response format:** pr●/MEDIA/AUDIO/XP.DestinationPortAutoselect=<O<sub>n</sub>\_set>

The response shows the settings of each output one by one.

**Legend:**

<O<sub>n</sub>\_set> Two-letter code of the Autoselect settings:

Letter	Explanation	
1 <sup>st</sup> letter	E:	Autoselect is <b>enabled</b> .
	D:	Autoselect is <b>disabled</b> .
2 <sup>nd</sup> letter	F:	<b>First</b> detect mode: the first active audio input is selected.
	P:	<b>Priority</b> detect mode: always the highest priority active audio input will be selected.
	L:	<b>Last</b> detect mode: always the last attached input is switched to the output automatically.
	S:	<b>Static</b> mode: the audio input follows the selected video if the video signal contains embedded audio.

**Example:**

```
> GET /MEDIA/AUDIO/XP.DestinationPortAutoselect
< pr /MEDIA/AUDIO/XP.DestinationPortAutoselect=EL
```

**Explanation:**

**EL:** the Autoselect is Enabled on output, selected mode is Last detect.

INFO: For more information about the Autoselect feature see [The Autoselect Feature](#) section.

### 7.7.6. Change the Autoselect Mode

**Command format:** CALL●/MEDIA/AUDIO/XP:setDestinationPortAutoselect(<O<sub>n</sub>>:<O<sub>n</sub>\_set>)

**Response format:** mO●/MEDIA/AUDIO/XP:setDestinationPortAutoselect

**Legend:** See at previous section.

**Example1:**

```
> CALL /MEDIA/AUDIO/XP:setDestinationPortAutoselect(O1:EPM)
< mO /MEDIA/AUDIO/XP:setDestinationPortAutoselect
```

**Explanation1:** The setting is changed to “EPM”: Autoselect is enabled (E); the mode is set to “priority detect” (P), and the port will be disconnected if a higher priority port becomes active (M).

**Example2:**

```
> CALL /MEDIA/AUDIO/XP:setDestinationPortAutoselect(O1:D)
< mO /MEDIA/AUDIO/XP:setDestinationPortAutoselect
```

**Explanation2:** The setting is changed to “DPM”: Autoselect is disabled (D). The other settings remain unchanged. Since the outputs are linked, the change will affect local and link out.

INFO: For more information about the Autoselect feature see [The Autoselect Feature](#) section.



### 7.7.7. Query the Input Port Priority

**Command format:** GET●/MEDIA/AUDIO/XP.PortPriorityList

**Response format:** pr●/MEDIA/AUDIO/XP.PortPriorityList=<O<sub>n</sub>\_list>

The response shows the priority of each output one after another. The priority number can be from 0 to 31; 0 is the highest- and 30 is the lowest priority. 31 means that the port will be skipped from the priority list.

**Legend:**

<O<sub>n</sub>\_list>      The input port priority order of the given output port: <I<sub>1</sub>>,<I<sub>2</sub>>,...,<I<sub>m</sub>>

**Example:**

```
> GET /MEDIA/AUDIO/XP.PortPriorityList
< pr /MEDIA/AUDIO/XP.PortPriorityList=0,1,2,3,4
```

**Explanation:**

Priority	0	1	...	x
Video input port	I1	I2	...	I <sub>m</sub>

Highest priority is assigned to I1 port.

**ATTENTION!** The same priority number can be set to different input ports. When the priority numbers match, the input port with the lowest port number will have the highest priority.

### 7.7.8. Change the Input Port Priority

**Command format:** CALL●/MEDIA/AUDIO/XP:setAutoselectionPriority(<I<sub>n</sub>><O<sub>m</sub>>:<prio>)

**Response format:** mO●/MEDIA/AUDIO/XP:setAutoselectionPriority

**Legend:**

<prio>:      Priority number from 0 to 31, equal numbers are allowed (31 means that the port will be skipped from the priority list).

An input port priority can be set on an output port. Many settings can be executed by separating a semicolon (no space), see the example below.

**Example:**

```
> CALL /MEDIA/VIDEO/XP:setAutoselectionPriority(I1\ (01\):4;I2\ (01\):4)
< mO /MEDIA/VIDEO/XP:setAutoselectionPriority
```

**Explanation:**

The priority number of input 1 and Input 2 has been set to 4 on output 1. The example shows that certain control characters have been escaped: the backslash “\” character is inserted before the “(” and “)” characters. See more information about the escaping in the [Escaping](#) section.

### 7.7.9. Mute an Audio Input

**Command format:** CALL●/MEDIA/AUDIO/XP:muteSource(<I<sub>n</sub>>)

**Response format:** mO●/MEDIA/AUDIO/XP:muteSource

**Example:**

```
> CALL /MEDIA/AUDIO/XP:muteSource(I1)
< mO /MEDIA/AUDIO/XP:muteSource
```

### 7.7.10. Unmute an Audio Input

**Command format:** CALL●/MEDIA/AUDIO/XP:unmuteSource(<I<sub>n</sub>>)

**Response format:** mO●/MEDIA/AUDIO/XP:unmuteSource

**Example:**

```
> CALL /MEDIA/AUDIO/XP:unmuteSource(I1)
< mO /MEDIA/AUDIO/XP:unmuteSource
```

### 7.7.11. Lock an Input Port

**Command format:** CALL●/MEDIA/AUDIO/XP:lockSource(<I<sub>n</sub>>)

**Response format:** mO●/MEDIA/AUDIO/XP:lockSource

**Example:**

```
> CALL /MEDIA/AUDIO/XP:lockSource(I1)
< mO /MEDIA/AUDIO/XP:lockSource
```

### 7.7.12. Unlock an Input Port

**Command format:** CALL●/MEDIA/AUDIO/XP:unlockSource(<I<sub>n</sub>>)

**Response format:** mO●/MEDIA/AUDIO/XP:unlockSource

**Example:**

```
> CALL /MEDIA/AUDIO/XP:unlockSource(I1)
< mO /MEDIA/AUDIO/XP:unlockSource
```

### 7.7.13. Mute Audio Output

**Command format:** CALL●/MEDIA/AUDIO/XP:muteDestination(<O<sub>n</sub>>)

**Response format:** mO●/MEDIA/AUDIO/XP:muteDestination

**Example:**

```
> CALL /MEDIA/AUDIO/XP:muteDestination(O1)
< mO /MEDIA/AUDIO/XP:muteDestination
```

**7.7.14. Unmute Audio Output****Command format:** CALL●/MEDIA/AUDIO/XP:unmuteDestination(<O<sub>n</sub>>)**Response format:** mO●/MEDIA/AUDIO/XP:unmuteDestination**Example:**

```
> CALL /MEDIA/AUDIO/XP:unmuteDestination(01)
< mO /MEDIA/AUDIO/XP:unmuteDestination
```

**7.7.15. Lock Output****Command format:** CALL●/MEDIA/AUDIO/XP:lockDestination(<O<sub>n</sub>>)**Response format:** mO●/MEDIA/AUDIO/XP:lockDestination**Example:**

```
> CALL /MEDIA/AUDIO/XP:lockDestination(01)
< mO /MEDIA/AUDIO/XP:lockDestination
```

**7.7.16. Unlock Output****Command format:** CALL●/MEDIA/AUDIO/XP:unlockDestination(<O<sub>n</sub>>)**Response format:** mO●/MEDIA/AUDIO/XP:unlockDestination**Example:**

```
> CALL /MEDIA/AUDIO/XP:unlockDestination(01)
< mO /MEDIA/AUDIO/XP:unlockDestination
```

**7.7.17. Analog Audio Input Level Settings**

INFO: The following settings are valid only for analog audio input ports of the transmitters.

**Volume (dB)****Command format:** SET●/MEDIA/AUDIO/<I<sub>n</sub>>.VolumedB=<level>**Response format:** pw●/MEDIA/AUDIO/<I<sub>n</sub>>.VolumedB=<level>**Parameters:**

<level> Sets the input volume (attenuation) between -95.625 dB and 0 dB in step of -0.375 dB. The value is rounded up if necessary to match with the step value.

**Example:**

```
> SET /MEDIA/AUDIO/I5.VolumedB=-15
< pw /MEDIA/AUDIO/I5.VolumedB=-15.00
```

**Volume (Percent)****Command format:** SET●/MEDIA/AUDIO/<I<sub>n</sub>>.VolumePercent=<percent>**Response format:** pw●/MEDIA/AUDIO/<I<sub>n</sub>>.VolumePercent=<percent>**Parameters:**

<level> Sets the output volume (attenuation) between 100% and 0%, in step of 1%. The value is rounded up if necessary to match with the step value.

**Example:**

```
> SET /MEDIA/AUDIO/I6.VolumePercent=50
< pw /MEDIA/AUDIO/I6.VolumePercent=50.00
```

**Balance****Command format:** SET●/MEDIA/AUDIO/<O<sub>n</sub>>.Balance=<level>**Response format:** pw●/MEDIA/AUDIO/<O<sub>n</sub>>.Balance=<level>**Parameters:**

<level> Sets the balance; -100 means left balance, 100 means right balance, step is 1. Center is 0 (default).

**Example:**

```
> SET /MEDIA/AUDIO/I6.Balance=0
< pw /MEDIA/AUDIO/I6.Balance=0
```

**Gain****Command format:** SET●/MEDIA/AUDIO/<I<sub>n</sub>>.Gain=<level>**Response format:** pw●/MEDIA/AUDIO/<I<sub>n</sub>>.Gain=<level>**Parameters:**

<level> Sets the input gain between -9 dB and 6 dB in step of 3 dB. The value is rounded down if necessary to match the step value.

**Example:**

```
> SET /MEDIA/AUDIO/I5.Gain=3
< pw /MEDIA/AUDIO/I5.Gain=3
```

### 7.7.18. Analog Audio Input Level Settings by Steps

INFO: The following settings are valid only for analog audio input ports of the transmitters.

#### Volume in dB

**Command format:** CALL●/MEDIA/AUDIO/<I<sub>n</sub>>.stepVolumedB=<step>

**Response format:** m0●/MEDIA/AUDIO/<I<sub>n</sub>>.stepVolumedB=<step>

**Parameters:**

<step> Volume is increased or decreased with the given value in dB.

**Example:**

```
> CALL /MEDIA/AUDIO/I5:stepVolumedB(-1)
< m0 /MEDIA/AUDIO/I5:stepVolumedB
```

**Explanation:** The volume is decreased with 1 dB, the current volume is -1 dB which means 91.21% in percent.

#### Volume in Percent

**Command format:** CALL●/MEDIA/AUDIO/<I<sub>n</sub>>.stepVolumePercent=<step>

**Response format:** m0●/MEDIA/AUDIO/<I<sub>n</sub>>.stepVolumePercent=<step>

**Parameters:**

<step> Volume is increased or decreased with the given value in percent.

**Example:**

```
> CALL /MEDIA/AUDIO/I5:stepVolumePercent(5)
< m0 /MEDIA/AUDIO/I5:stepVolumePercent
```

**Explanation:** The volume is increased with 5%, the current volume is -0.83 dB which means 95% in percent.

#### Balance

**Command format:** CALL●/MEDIA/AUDIO/<I<sub>n</sub>>.stepBalance=<step>

**Response format:** m0●/MEDIA/AUDIO/<I<sub>n</sub>>.stepBalance=<step>

**Parameters:**

<step> Balance is shifted to left or right depends on the given value. -100 means left balance, 100 means right balance, step is 1. Center is 0 (default).

**Example:**

```
> CALL /MEDIA/AUDIO/I5:stepBalance(1)
< m0 /MEDIA/AUDIO/I5:stepBalance
```

**Explanation:** The balance is shifted to right with 1 step.

### 7.7.19. Analog Audio Output Level Settings

INFO: The following settings are valid only for analog audio output port of the receiver.

#### Volume (dB)

**Command format:** SET●/MEDIA/AUDIO/<O<sub>n</sub>>.VolumedB=<level>

**Response format:** pw●/MEDIA/AUDIO/<O<sub>n</sub>>.VolumedB=<level>

**Parameters:**

<level> Sets the output volume (attenuation) between -95.625 dB and 0 dB in step of -0.375 dB. The value is rounded up if necessary to match with the step value.

**Example:**

```
> SET /MEDIA/AUDIO/O3.VolumedB=-15
< pw /MEDIA/AUDIO/O3.VolumedB=-15.00
```

#### Volume (Percent)

**Command format:** SET●/MEDIA/AUDIO/<O<sub>n</sub>>.VolumePercent=<percent>

**Response format:** pw●/MEDIA/AUDIO/<O<sub>n</sub>>.VolumePercent=<percent>

**Parameters:**

<level> Sets the output volume (attenuation) between 100% and 0%, in step of 1%. The value is rounded up if necessary to match with the step value.

**Example:**

```
> SET /MEDIA/AUDIO/O3.VolumePercent=50
< pw /MEDIA/AUDIO/O3.VolumePercent=50.00
```

#### Balance

**Command format:** SET●/MEDIA/AUDIO/<O<sub>n</sub>>.Balance=<level>

**Response format:** pw●/MEDIA/AUDIO/<O<sub>n</sub>>.Balance=<level>

**Parameters:**

<level> Sets the balance; -100 means left balance, 100 means right balance, step is 1. Center is 0 (default).

**Example:**

```
> SET /MEDIA/AUDIO/O3.Balance=0
< pw /MEDIA/AUDIO/O3.Balance=0
```

### 7.7.20. Analog Audio Output Level Settings by Steps

INFO: The following settings are valid only for analog audio output port of the receiver.

#### Volume in dB

**Command format:** CALL●/MEDIA/AUDIO/<O<sub>n</sub>>.stepVolumedB=<step>

**Response format:** m0●/MEDIA/AUDIO/<O<sub>n</sub>>.stepVolumedB=<step>

**Parameters:**

<step> Volume is increased or decreased with the given value in dB.

**Example:**

```
> CALL /MEDIA/AUDIO/03:stepVolumedB(-1)
< m0 /MEDIA/AUDIO/03:stepVolumedB
```

**Explanation:**

The volume is decreased with 1 dB, the current volume is -1.95 dB which means 77.84% in percent.

#### Volume in Percent

**Command format:** CALL●/MEDIA/AUDIO/<O<sub>n</sub>>.stepVolumePercent=<step>

**Response format:** m0●/MEDIA/AUDIO/<O<sub>n</sub>>.stepVolumePercent=<step>

**Parameters:**

<step> Volume is increased or decreased with the given value in percent.

**Example:**

```
> CALL /MEDIA/AUDIO/03:stepVolumePercent(5)
< m0 /MEDIA/AUDIO/03:stepVolumePercent
```

**Explanation:**

The volume is increased with 5%, the current volume is -1.52 dB which means 82.84% in percent.

## 7.8. Network Configuration

### 7.8.1. Query the DHCP State

**Command format:** GET●/MANAGEMENT/NETWORK.DhcpEnabled

**Response format:** pw●/MANAGEMENT/NETWORK.DhcpEnabled=true|false

**Example:**

```
> GET /MANAGEMENT/NETWORK.DhcpEnabled
< pw /MANAGEMENT/NETWORK.DhcpEnabled=true
```

### 7.8.2. Change the DHCP State

**Command format:** SET●/MANAGEMENT/NETWORK.DhcpEnabled=true|false

**Response format:** pw●/MANAGEMENT/NETWORK.DhcpEnabled=true|false

**Example:**

```
> SET /MANAGEMENT/NETWORK.DhcpEnabled=false
< pw /MANAGEMENT/NETWORK.DhcpEnabled=false
```

### 7.8.3. Query the IP Address

**Command format:** GET●/MANAGEMENT/NETWORK.IpAddress

**Response format:** pr●/MANAGEMENT/NETWORK.IpAddress=<IP\_Address>

**Example:**

```
> GET /MANAGEMENT/NETWORK.IpAddress
< pr /MANAGEMENT/NETWORK.IpAddress=192.168.0.100
```

### 7.8.4. Change the IP Address (Static)

**Command format:** SET●/MANAGEMENT/NETWORK.StaticIpAddress=<IP\_address>

**Response format:** pw●/MANAGEMENT/NETWORK.StaticIpAddress=<IP\_address>

**Example:**

```
> SET /MANAGEMENT/NETWORK.StaticIpAddress=192.168.0.85
< pw /MANAGEMENT/NETWORK.StaticIpAddress=192.168.0.85
```

### 7.8.5. Query the Subnet Mask

**Command format:** GET●/MANAGEMENT/NETWORK.NetworkMask

**Response format:** pr●/MANAGEMENT/NETWORK.NetworkMask=<netmask>

**Example:**

```
> GET /MANAGEMENT/NETWORK.NetworkMask
< pr /MANAGEMENT/NETWORK.NetworkMask=255.255.255.0
```

### 7.8.6. Change the Subnet Mask (Static)

**Command format:** SET●/MANAGEMENT/NETWORK.StaticNetworkMask=<netmask>

**Response format:** pw●/MANAGEMENT/NETWORK.StaticNetworkMask=<netmask>

**Example:**

```
> SET /MANAGEMENT/NETWORK.StaticNetworkMask=255.255.255.0
< pw /MANAGEMENT/NETWORK.StaticNetworkMask=255.255.255.0
```

### 7.8.7. Query the Gateway Address

**Command format:** GET●/MANAGEMENT/NETWORK.GatewayAddress

**Response format:** pr●/MANAGEMENT/NETWORK.GatewayAddress=<gw\_address>

**Example:**

```
> GET /MANAGEMENT/NETWORK.GatewayAddress
< pr /MANAGEMENT/NETWORK.GatewayAddress=192.168.0.1
```

### 7.8.8. Change the Gateway Address (Static)

**Command format:** SET●/MANAGEMENT/NETWORK.StaticGatewayAddress=<gw\_address>

**Response format:** pw●/MANAGEMENT/NETWORK.StaticGatewayAddress=<gw\_address>

**Example:**

```
> SET /MANAGEMENT/NETWORK.StaticGatewayAddress=192.168.0.5
< pw /MANAGEMENT/NETWORK.StaticGatewayAddress=192.168.0.5
```

### 7.8.9. Apply Network Settings

**Command format:** CALL●/MANAGEMENT/NETWORK:ApplySettings()

**Response format:** m0●/MANAGEMENT/NETWORK: ApplySettings

**Example:**

```
> CALL /MANAGEMENT/NETWORK:ApplySettings()
< m0 /MANAGEMENT/NETWORK:ApplySettings
```

**Explanation:** All network settings which are changed have been applied.

## 7.9. RS-232 Port Configuration

INFO: RS-232 port numbering can be found in the [Input/Output Port Numbering](#) section.

### 7.9.1. Protocol Setting

**Command format:** SET●/MEDIA/UART/<P<sub>n</sub>>.ControlProtocol=0|1

**Response format:** pw●/MEDIA/UART/<P<sub>n</sub>>.ControlProtocol=0|1

**Parameters:**

.ControlProtocol	0	1
RS-232 protocol mode	LW2	LW3

**Example:**

```
> SET /MEDIA/UART/P1.ControlProtocol=1
< pw /MEDIA/UART/P1.ControlProtocol=1
```

### 7.9.2. BAUD Rate Setting

**Command format:** SET●/MEDIA/UART/<P<sub>n</sub>>.Baudrate=0|1|2|3|4|5|6|7

**Response format:** pw●/MEDIA/UART/<P<sub>n</sub>>.Baudrate=0|1|2|3|4|5|6|7

**Parameters:**

.Baudrate	0	1	2	3	4	5	6	7
BAUD rate value	4800	7200	9600	14400	19200	38400	57600	115200

**Example:**

```
> SET /MEDIA/UART/P1.Baudrate=2
< pw /MEDIA/UART/P1.Baudrate=2
```

### 7.9.3. Databit Setting

**Command format:** SET●/MEDIA/UART/<P<sub>n</sub>>.DataBits=8|9

**Response format:** pw●/MEDIA/UART/<P<sub>n</sub>>.DataBits=8|9

**Example:**

```
> SET /MEDIA/UART/P1.DataBits=8
< pw /MEDIA/UART/P1.DataBits=8
```

### 7.9.4. Stopbits Setting

**Command format:** SET●/MEDIA/UART/<P<sub>n</sub>>.StopBits=0|1|2

**Response format:** pw●/MEDIA/UART/<P<sub>n</sub>>.StopBits=0|1|2

**Parameters:**

.StopBits	0	1	2
Stopbit value	1	1,5	2

**Example:**

```
> SET /MEDIA/UART/P1.StopBits=0
< pw /MEDIA/UART/P1.StopBits=0
```

### 7.9.5. Parity Setting

**Command format:** SET●/MEDIA/UART/<P<sub>n</sub>>.Parity=0|1|2

**Response format:** pw●/MEDIA/UART/<P<sub>n</sub>>.Parity=0|1|2

**Parameters:**

.Parity	0	1	2
Parity setting	no parity	odd	even

**Example:**

```
> SET /MEDIA/UART/P1.Parity=0
< pw /MEDIA/UART/P1.Parity=0
```

### 7.9.6. RS-232 Operation Mode

**Command format:** SET●/MEDIA/UART/<P<sub>n</sub>>.Rs232Mode=0|1|2

**Response format:** pw●/MEDIA/UART/<P<sub>n</sub>>.Rs232Mode=0|1|2

**Parameters:**

.Rs232Mode	0	1	2
RS-232 operation mode	Pass-through	Control	Command injection

**Example:**

```
> SET /MEDIA/UART/P1.Rs232Mode=1
< pw /MEDIA/UART/P1.Rs232Mode=1
```

INFO: See more information about RS-232 modes in the [Serial Interface](#) section.

### Command Injection Mode

**Command format:** SET●/MEDIA/UART/<P<sub>n</sub>>.CommandInjectionEnable=true|false

**Response format:** pw●/MEDIA/UART/<P<sub>n</sub>>.CommandInjectionEnable=true|false

**Example:**

```
> SET /MEDIA/UART/P1.CommandInjectionEnable=true
< pw /MEDIA/UART/P1.CommandInjectionEnable=true
```

**ATTENTION!** The Command injection status is stored in another read-only property: /MEDIA/UART/<P<sub>n</sub>>.CommandInjectionStatus.

## 7.10. Sending Message via the Communication Ports

### 7.10.1. Sending Message via TCP Port

The device can be used for sending a message to a certain IP:port address. The three different commands allow controlling the connected (third-party) devices.

#### Sending TCP Message

The command is for sending a command messages in ASCII-format with an option for escaping special characters.

**Command format:** CALL●/MEDIA/ETHERNET.tcpMessage(<IP\_address>:<port\_no>=<message>)

**Response format:** mO●/MEDIA/ETHERNET:tcpMessage

**Example:**

```
> CALL /MEDIA/ETHERNET.tcpMessage(192.168.0.20:5555=PWR0\x0d\x0a)
< mO /MEDIA/ETHERNET:tcpMessage
```

#### Escaping in the Message

When commands need to be separated by <CR><LF> characters to be recognized by the controlled device, then they need to be escaped. You can use the following format for escaping:

<command<sub>1</sub>><\x0d\x0a><command<sub>2</sub>><\x0d\x0a>...<command<sub>n</sub>><\x0d\x0a>

#### Sending Text Message

The command is for sending a text message in ASCII-format.

INFO: Escaping will not be processed using the **tcpText** command.

**Command format:** CALL●/MEDIA/ETHERNET.tcpText(<IP\_address>:<port\_no>=<message>)

**Response format:** mO●/MEDIA/ETHERNET:tcpText

**Example:**

```
> CALL /MEDIA/ETHERNET.tcpText(192.168.0.20:5555=pwr_on)
< mO /MEDIA/ETHERNET:tcpText
```

#### Sending Binary Message

The command is for sending a binary message in HEX format.

INFO: Escaping will not be processed using the **tcpBinary** command.

**Command format:** CALL●/MEDIA/ETHERNET.tcpBinary(<IP\_address>:<port\_no>=<message>)

**Response format:** mO●/MEDIA/ETHERNET:tcpBinary

**Example:**

```
> CALL /MEDIA/ETHERNET.tcpBinary(192.168.0.20:5555=010000006162000cdcc2c40)
< mO /MEDIA/ETHERNET:tcpBinary
```

### 7.10.2. Sending Message via UDP Port

The device can be used for sending a message to a certain IP:port address. The three different commands allow controlling the connected (third-party) devices.

#### Sending UDP Message

The command is for sending a command messages in ASCII-format with an option for escaping special characters.

**Command format:** CALL●/MEDIA/ETHERNET.udpMessage(<IP\_address>:<port\_no>=<message>)

**Response format:** mO●/MEDIA/ETHERNET:udpMessage

**Example:**

```
> CALL /MEDIA/ETHERNET.udpMessage(192.168.0.20:5555=PWR0\x0d\x0a)
< mO /MEDIA/ETHERNET:udpMessage
```

#### Escaping in the Message

When commands need to be separated by <CR><LF> characters to be recognized by the controlled device, then they need to be escaped. You can use the following format for escaping:

*<command<sub>1</sub>><\x0d\x0a><command<sub>2</sub>><\x0d\x0a>...<command<sub>n</sub>><\x0d\x0a>*

#### Sending Text Message

The command is for sending a text message in ASCII-format.

■ INFO: Escaping will not be processed using the **udpText** command.

**Command format:** CALL●/MEDIA/ETHERNET.udpText(<IP\_address>:<port\_no>=<message>)

**Response format:** mO●/MEDIA/ETHERNET:udpText

**Example:**

```
> CALL /MEDIA/ETHERNET.udpText(192.168.0.20:5555=pwr_on)
< mO /MEDIA/ETHERNET:udpText
```

#### Sending Binary Message

The command is for sending a binary message in HEX format.

■ INFO: Escaping will not be processed using the **udpBinary** command.

**Command format:** CALL●/MEDIA/ETHERNET.udpBinary(<IP\_address>:<port\_no>=<message>)

**Response format:** mO●/MEDIA/ETHERNET:udpBinary

**Example:**

```
> CALL /MEDIA/ETHERNET.udpBinary(192.168.0.20:5555=0100000061620000cdcc2c40)
< mO /MEDIA/ETHERNET:udpBinary
```

### 7.10.3. Sending Message via an RS-232 Port

The RS-232 ports can be used for sending a command message to a device which can be controlled over serial port. Both local RS-232 and extended link RS-232 ports can be used. The three different commands allow to use different message formats.

#### Sending Message

The command is for sending a command messages in ASCII-format with an option for escaping special characters.

**Command format:** CALL●/MEDIA/UART/<P<sub>n</sub>>.sendMessage(<message>)

**Response format:** mO●/MEDIA/UART/<P<sub>n</sub>>:sendMessage

**Example:**

```
> CALL /MEDIA/UART/P1.sendMessage(PWR0\x0d\x0a)
< mO /MEDIA/UART/P1:sendMessage
```

#### Escaping in the Message

When commands need to be separated by <CR><LF> characters to be recognized by the controlled device, then they need to be escaped. You can use the following format for escaping:

*<command<sub>1</sub>><\x0d\x0a><command<sub>2</sub>><\x0d\x0a>...<command<sub>n</sub>><\x0d\x0a>*

#### Sending Text Message

The command is for sending a text message in ASCII-format.

■ INFO: Escaping will not be processed using the **sendText** command.

**Command format:** CALL●/MEDIA/UART/<P<sub>n</sub>>.sendText(<message>)

**Response format:** mO●/MEDIA/UART/<P<sub>n</sub>>:sendText

**Example:**

```
> CALL /MEDIA/UART/P1.sendText(pwr_on)
< mO /MEDIA/UART/P1:sendText
```

#### Sending Binary Message

The command is for sending a binary message in HEX format.

■ INFO: Escaping will not be processed using the **sendBinaryMessage** command.

**Command format:** CALL●/MEDIA/UART/<P<sub>n</sub>>.sendBinaryMessage(<message>)

**Response format:** mO●/MEDIA/UART/<P<sub>n</sub>>:sendBinaryMessage

**Example:**

```
> CALL /MEDIA/UART/P1.sendBinaryMessage(0100000061620000cdcc2c40)
< mO /MEDIA/UART/P1:sendBinaryMessage
```

## 7.11. GPIO Port Configuration

INFO: Use the GET command to query a parameter.

### 7.11.1. Set the Direction of a GPIO Pin

**Command format:** SET●/MEDIA/GPIO/P<sub>n</sub>.Direction=<dir>

**Response format:** pw●/MEDIA/GPIO/ P<sub>n</sub>.Direction=<dir>

**Legend:** <dir>: direction of the GPIO pin: I=input; O=output

**Example:**

```
> SET /MEDIA/GPIO/P1.Direction=I
< pw /MEDIA/GPIO/P1.Direction=I
```

### 7.11.2. Set the Output Level of a GPIO Pin

**Command format:** SET●/MEDIA/GPIO/P<sub>n</sub>.Output=<value>

**Response format:** pw●/MEDIA/GPIO/ P<sub>n</sub>.Output=<value>

**Legend:** <value>: value of the GPIO pin: H=high level; L=low level

**Example:**

```
> SET /MEDIA/GPIO/P1.Output
< pw /MEDIA/GPIO/P1.Output=H
```

### 7.11.3. Toggle the Level of a GPIO Pin

**Command format:** CALL●/MEDIA/GPIO/P<sub>n</sub>:toggle()

**Response format:** pw●/MEDIA/GPIO/ P<sub>n</sub>:toggle

```
> CALL●/MEDIA/GPIO/P1:toggle()
< m0 /MEDIA/GPIO/P1:toggle
```

**Explanation:** If the direction of the pin is input: the output value is toggled.  
If the direction of the pin is output: the output value and the input value are toggled.

## 7.12. EDID Management

### 7.12.1. Query the Emulated EDIDs

**Command format:** GET●/EDID.EdidStatus

**Response format:** pr●/EDID.EdidStatus=<E<sub>loc</sub>>:<E<sub>1</sub>>;<E<sub>loc</sub>>:<E<sub>2</sub>>;...;<E<sub>loc</sub>>:<E<sub>n</sub>>

**Example:**

```
> GET /EDID.EdidStatus
< pr /EDID.EdidStatus=D1:E1;D1:E2;D1:E3;D1:E4
```

**Explanation:** Emulated EDID memory for input port is listed with the EDID number that is currently emulated on the input.

### 7.12.2. Query the Validity of a Dynamic EDID

**Command format:** GET●/EDID/D/D<sub>n</sub>.Validity

**Response format:** pr●/EDID/D/D<sub>n</sub>.Validity=true|false

**Example:**

```
> GET /EDID/D/D1.Validity
< pr /EDID/D/D1.Validity=true
```

**Explanation:** The 'Validity' property is true, valid EDID is stored in D1 memory place.

### 7.12.3. Query the Preferred Resolution of an User EDID

**Command format:** GET●/EDID/U/U<sub>n</sub>.PreferredResolution

**Response format:** pr●/EDID/U/U<sub>n</sub>.PreferredResolution=<preferred\_resolution>

**Example:**

```
> GET /EDID/U/U2.PreferredResolution
< pr /EDID/U/U2.PreferredResolution=1920x1080p60.00Hz
```

INFO: Use the "Manufacturer" property to query the manufacturer and the "MonitorName" property to query the name of the monitor.

### 7.12.4. Emulating an EDID to an Input Port

**Command format:** CALL●/EDID:switch(<source>:<destination>)

**Response format:** mO●/EDID:switch

**Example:**

```
> CALL /EDID:switch(F49:E2)
< m0 /EDID:switch
```

**Legend:** <source>: Source EDID memory place: Factory / User / Dynamic.  
<destination>: The emulated EDID memory of the desired input port.



### 7.12.5. Emulating an EDID to All Input Ports

**Command format:** CALL●/EDID:switchAll(<source>)

**Response format:** mO●/EDID:switchAll

**Example:**

```
> CALL /EDID:switchAll(F47)
< mO /EDID:switchAll
```

**Legend:** <source> Source EDID memory place: Factory / User / Dynamic.

### 7.12.6. Copy an EDID to User Memory

**Command format:** CALL●/EDID:copy(<D<sub>n</sub>>|<E<sub>n</sub>>|<F<sub>n</sub>>|<U<sub>n</sub>>:<U<sub>m</sub>>)

**Response format:** mO●/EDID:copy

**Example:**

```
> CALL /EDID:copy(D1:U1)
< mO /EDID:copy
```

**Explanation:** The EDID of the last connected sink of D1 (Output 1) has been copied to U1.

### 7.12.7. Deleting an EDID from User Memory

**Command format:** CALL●/EDID:delete(<U<sub>n</sub>>)

**Response format:** mO●/EDID:delete

**Example:**

```
> CALL /EDID:delete(U1)
< mO /EDID:delete
```

### 7.12.8. Resetting the Emulated EDIDs

**Command format:** CALL●/EDID:reset()

**Response format:** mO●/EDID:reset

**Example:**

```
> CALL /EDID:reset()
< mO /EDID:reset
```

**Explanation:** Calling this method switches all emulated EDIDs to factory default one. See the table in the [Factory EDID List](#) section.

## 7.13. LW3 Commands - Quick Summary

### System Commands

Operation / Path	
7.5.1	Query the Product Name
	/ProductName
7.5.2	Set the Device Label
	/MANAGEMENT/UID.DeviceLabel
7.5.3	Query the Serial Number
	/SerialNumber
7.5.4	Query the Firmware Version
	/SYS/MB.FirmwareVersion
7.5.5	Resetting the Device
	/SYS:reset()
7.5.6	Restore the Factory Default Settings
	/SYS:factoryDefaults()

### Video Port Settings

Operation / Path	
7.6.1	Query the Status of Source Ports
	/MEDIA/VIDEO/XP.SourcePortStatus
7.6.2	Query the Status of Destination Port
	/MEDIA/VIDEO/XP.DestinationPortStatus
7.6.3	Query the Video Crosspoint Setting
	/MEDIA/VIDEO/XP.DestinationConnectionList
7.6.4	Switching Video Input
	/MEDIA/VIDEO/XP:switch(<input>:<output>)
7.6.5	Query the Video Autoselect Settings
	/MEDIA/VIDEO/XP.DestinationPortAutoselect
7.6.6	Change the Autoselect Mode
	/MEDIA/VIDEO/XP:setDestinationPortAutoselect(<output>:<output_set>)
7.6.7	Query the Input Port Priority
	/MEDIA/VIDEO/XP.PortPriorityList

Operation / Path	
7.6.8	Change the Input Port Priority
	/MEDIA/VIDEO/XP:setAutoselectionPriority(<input>(<output>):<prio>)
7.6.9	Mute an Input Port
	/MEDIA/VIDEO/XP:muteSource(<input>)
7.6.10	Unmute an Input Port
	/MEDIA/VIDEO/XP:unmuteSource(<input>)
7.6.11	Lock an Input Port
	/MEDIA/VIDEO/XP:lockSource(<input>)
7.6.12	Unlock an Input Port
	/MEDIA/VIDEO/XP:unlockSource(<input>)
7.6.13	Mute Output
	/MEDIA/VIDEO/XP:muteDestination(<output>)
7.6.14	Unmute Output
	/MEDIA/VIDEO/XP:unmuteDestination(<output>)
7.6.15	Lock Output
	/MEDIA/VIDEO/XP:lockDestination(<output>)
7.6.16	Unlock Output
	/MEDIA/VIDEO/XP:unlockDestination(<output>)
7.6.17	HDCP Setting (Input Port)
	/MEDIA/VIDEO/<input>.HdcpEnable
7.6.18	HDCP Setting (Output Port)
	/MEDIA/VIDEO/<output>.HdcpModeSetting
7.6.19	Test Pattern Generator
	/MEDIA/VIDEO/<output>.TpgMode TpgClockSource TpgPattern
7.6.20	HDMI Mode Settings (Output Port)
	/MEDIA/VIDEO/<output>.HdmiModeSetting

**Audio Port Settings**

Operation / Path	
7.7.1	Query the Status of Source Ports
	/MEDIA/AUDIO/XP.SourcePortStatus
7.7.2	Query the Status of Destination Port
	/MEDIA/AUDIO/XP.DestinationPortStatus
7.7.3	Query the Audio Crosspoint Setting
	/MEDIA/AUDIO/XP.DestinationConnectionList
7.7.4	Switching Audio Input
	/MEDIA/AUDIO/XP:switch(<input>:<output>)
7.7.5	Query the Audio Autoselect Settings
	/MEDIA/AUDIO/XP.DestinationPortAutoselect
7.7.6	Change the Autoselect Mode
	/MEDIA/AUDIO/XP:setDestinationPortAutoselect(<output>:<output_set>)
7.7.7	Query the Input Port Priority
	/MEDIA/AUDIO/XP.PortPriorityList
7.7.8	Change the Input Port Priority
	/MEDIA/AUDIO/XP:setAutoselectionPriority(<input>(<output>):<prio>)
7.7.9	Mute an Audio Input
	/MEDIA/AUDIO/XP:muteSource(<input>)
7.7.10	Unmute an Audio Input
	/MEDIA/AUDIO/XP:unmuteSource(<input>)
7.7.11	Lock an Input Port
	/MEDIA/AUDIO/XP:lockSource(<input>)
7.7.12	Unlock an Input Port
	/MEDIA/AUDIO/XP:unlockSource(<input>)
7.7.13	Mute Audio Output
	/MEDIA/AUDIO/XP:muteDestination(<output>)
7.7.14	Unmute Audio Output
	/MEDIA/AUDIO/XP:unmuteDestination(<output>)
7.7.15	Lock Output
	/MEDIA/AUDIO/XP:lockDestination(<output>)

Operation / Path	
7.7.16	Unlock Output
	/MEDIA/AUDIO/XP:unlockDestination(<output>)
7.7.17	Analog Audio Input Level Settings
	/MEDIA/AUDIO/<input>.VolumedB VolumePercent Balance Gain
7.7.18	Analog Audio Input Level Settings by Steps
	/MEDIA/AUDIO/<input>.stepVolumedB stepVolumePercent stepBalance
7.7.19	Analog Audio Output Level Settings
	/MEDIA/AUDIO/<output>.VolumedB VolumePercent Balance
7.7.20	Analog Audio Output Level Settings by Steps
	/MEDIA/AUDIO/<output>.stepVolumedB stepVolumePercent

**Network Configuration**

Operation / Path	
7.8.1	Query the DHCP State
	/MANAGEMENT/NETWORK.DhcpEnabled
7.8.2	Change the DHCP State
	/MANAGEMENT/NETWORK.DhcpEnabled
7.8.3	Query the IP Address
	/MANAGEMENT/NETWORK.IpAddress
7.8.4	Change the IP Address (Static)
	/MANAGEMENT/NETWORK.StaticIpAddress
7.8.5	Query the Subnet Mask
	MANAGEMENT/NETWORK.NetworkMask
7.8.6	Change the Subnet Mask (Static)
	/MANAGEMENT/NETWORK.StaticNetworkMask
7.8.7	Query the Gateway Address
	/MANAGEMENT/NETWORK.GatewayAddress
7.8.8	Change the Gateway Address (Static)
	/MANAGEMENT/NETWORK.StaticGatewayAddress
7.8.9	Apply Network Settings
	/MANAGEMENT/NETWORK:ApplySettings()

**RS-232 Port Configuration**

Operation / Path	
7.9.1	Protocol Setting
	/MEDIA/UART/<port_no>.ControlProtocol
7.9.2	BAUD Rate Setting
	/MEDIA/UART/<port_no>.Baudrate
7.9.3	Databit Setting
	/MEDIA/UART/<port_no>.DataBits
7.9.4	Stopbits Setting
	/MEDIA/UART/<port_no>.StopBits
7.9.5	Parity Setting
	/MEDIA/UART/<port_no>.Parity
7.9.6	RS-232 Operation Mode
	/MEDIA/UART/<port_no>.Rs232Mode

**Sending Message via the Communication Ports**

Operation / Path	
7.10.1	Sending Message via TCP Port
	/MEDIA/ETHERNET.tcpText tcpMessage tcpBinary
7.10.2	Sending Message via UDP Port
	/MEDIA/ETHERNET.udpText udpMessage udpBinary
7.10.3	Sending Message via an RS-232 Port
	/MEDIA/UART/<port_no>.sendText sendMessage sendBinaryMessage

**GPIO Port Configuration**

Operation / Path	
7.11.1	Set the Direction of a GPIO Pin
	/MEDIA/GPIO/<pin>.Direction
7.11.2	Set the Output Level of a GPIO Pin
	/MEDIA/GPIO/<pin>.Output
7.11.3	Toggle the Level of a GPIO Pin
	/MEDIA/GPIO/<pin>.toggle()

**EDID Management**

Operation / Path	
7.12.1	Query the Emulated EDIDs
	/EDID.EdidStatus
7.12.2	Query the Validity of a Dynamic EDID
	/EDID/D/<dynamic_edid_memory>.Validity
7.12.3	Query the Preferred Resolution of a User EDID
	/EDID/U/<user_edid_memory>.PreferredResolution
7.12.4	Emulating an EDID to an Input Port
	/EDID:switch(<source>:<destination>)
7.12.5	Emulating an EDID to All Input Ports
	/EDID:switchAll(<source>)
7.12.6	Copy an EDID to User Memory
	/EDID:copy(<source>:<destination>)
7.12.7	Deleting an EDID from User Memory
	/EDID:delete(<user_edid_memory>)
7.12.8	Resetting the Emulated EDIDs
	/EDID:reset()

# 8

## Firmware Upgrade

The extender can be upgraded by using Lightware Device Updater (LDU) software over USB. The firmware pack with the necessary components (\*.lfp file) for your specific product, the LDU application, and the User's manual can be downloaded from the Support page of our website [www.lightware.com](http://www.lightware.com).

- ▶ [ABOUT THE FIRMWARE PACKAGE \(LFP FILE\)](#)
- ▶ [SHORT INSTRUCTIONS](#)
- ▶ [INSTALL AND UPGRADE](#)
- ▶ [DETAILED INSTRUCTIONS](#)
- ▶ [KEEPING THE CONFIGURATION SETTINGS](#)

**ATTENTION!** While the firmware is being upgraded, the normal operation mode is suspended as the transmitter is switched to bootload mode. Signal processing is not performed. Do not interrupt the firmware upgrade. If any problem occurs, reboot the device and restart the process.

**ATTENTION!** The firmware upgrade process has an effect on the configuration and the settings of the device. For more details, please see the [Keeping the Configuration Settings](#) section before the upgrade.

### 8.1. About the Firmware Package (LFP file)

The firmware files are packed in one package which is called LFP file. You need only this file to do the upgrade on your device.

- The package contains all the necessary components, binary, and other files; You do not have to get further files.
- There is a descriptor file in the package that contains each firmware with version number and a list showing the compatible devices. The descriptor is displayed after loaded the LFP file in the LDU.

### 8.2. Short Instructions

**Step 1.** Get the firmware pack and the Lightware Device Updater (LDU) application.

**Step 2.** Install the LDU application.

**Step 3.** Establish the connection between the computer and the device(s).

**Step 4.** Start the LDU and follow the instructions shown on the screen.

### 8.3. Install and Upgrade

#### Installation for Windows OS

**INFO:** The application can be installed under Windows XP or above.

Run the installer. If the User Account Control drops a pop-up message click **Yes**. During the installation you will be prompted to select the type of the installation:

Normal install	Snapshot install
Available for Windows and Mac OS X	Available for Windows
The installer can update only this instance	Cannot be updated
Only one updateable instance can exist for all users	More than one different version can be installed for all users

*Comparison of install types*

**ATTENTION!** Using the Normal install as the default value is highly recommended.

#### Installation for Mac OS X

**INFO** After the installation the Windows and the Mac application has the same look and functionality. This type of the installer is equal with the Normal install in case of Windows and results an updateable version with the same attributes.

Mount the DMG file with double clicking on it and drag the LDU icon over the Applications icon to copy the program into the Applications folder. If you want to copy the LDU into another location just drag the icon over the desired folder.

#### LDU Upgrade

**Step 1.** Run the application. In the welcome screen click on the  button in the top right corner; the About window will appear. Click on the **Check now** button. The program checks the available updates on Lightware website and shows its version.

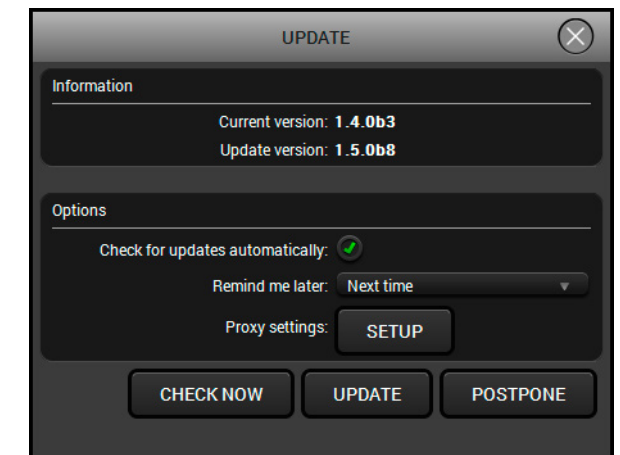

## 8.4. Detailed Instructions

### 8.4.1. Establish the Connection

Make sure that the computer and the device are connected via a USB mini cable and the connection is established between them.

### 8.4.2. Prepare the Firmware Upgrade in LDC

The device can be upgraded over USB in case of the USB crosspoint is set to the **Composite** channel only.

Start the Lightware Device Controller (LDC) software and navigate to the Crosspoint menu - USB tab. Check the crosspoint state and set it to the Composite channel.

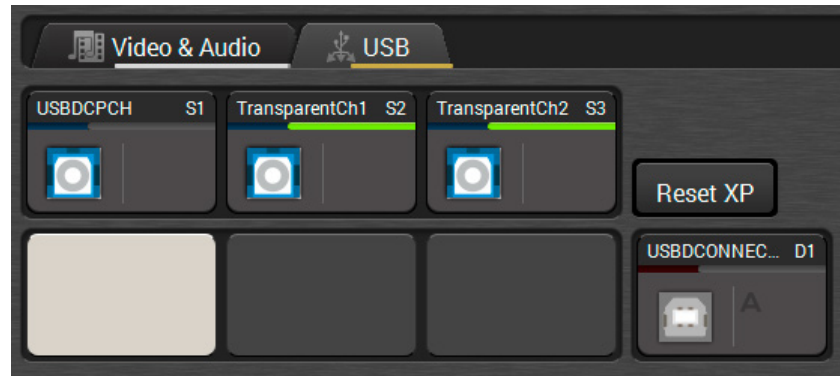

**USB crosspoint - Composite mode in LDC**

**ATTENTION!** After the setting is done it is highly recommended to close the LDC software to avoid the possible connection problem between the device and the LDU software.

### 8.4.3. Start the LDU and Follow the Instructions

After launching LDU welcome screen appears:

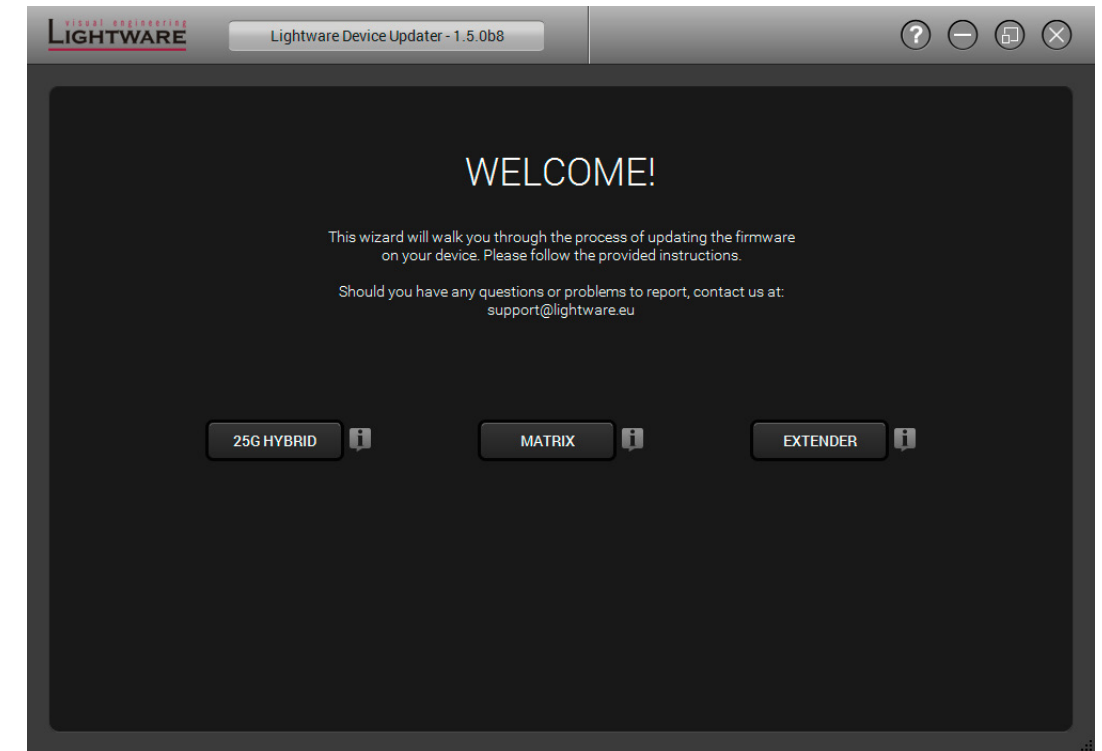

After pressing the **i** button a list will appear showing the supported devices:

Click on the **Extender** button on the main screen.

**Step 1.** Select the package.

Click on the Browse button and select the “.lfp” file that will be used for the upgrade.

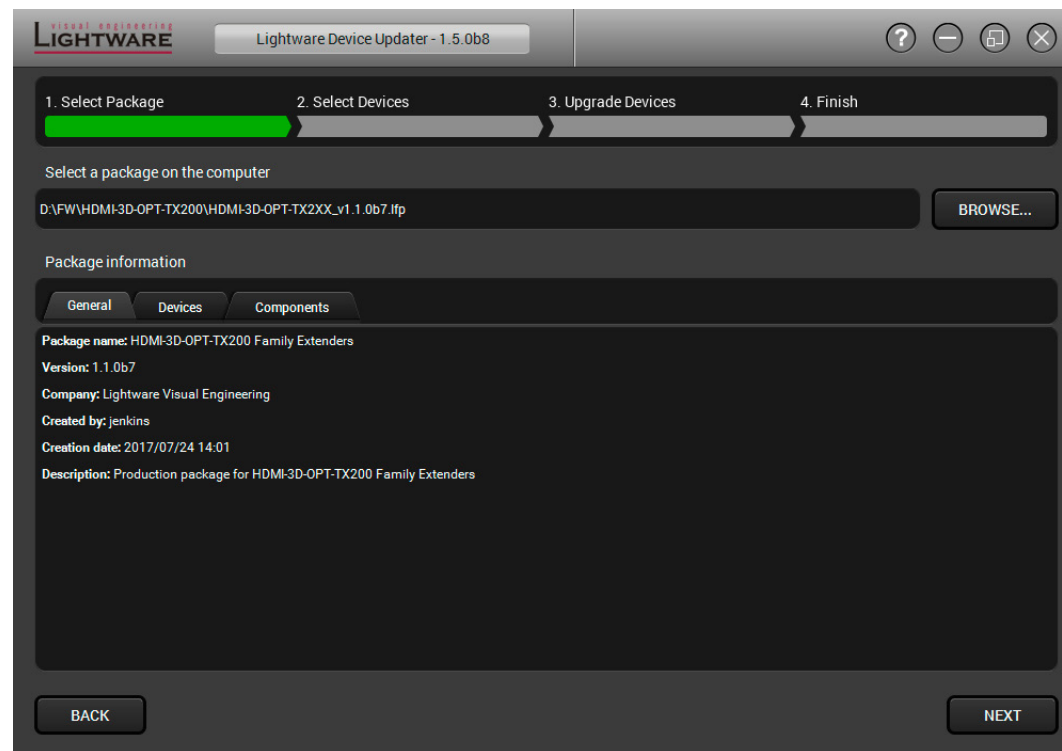

The package information is displayed:

- **General** version info, creation date, short description,
- **Devices** which are compatible with the firmware,
- **Components** in the package with release notes.

Click on the **Next** button and follow the instructions.

**TIPS AND TRICKS:** Files with “.lfp” extension are associated to LDU during installation. If you double click on the “.lfp” file, the application is launched, the package is loaded automatically and the screen above is shown.

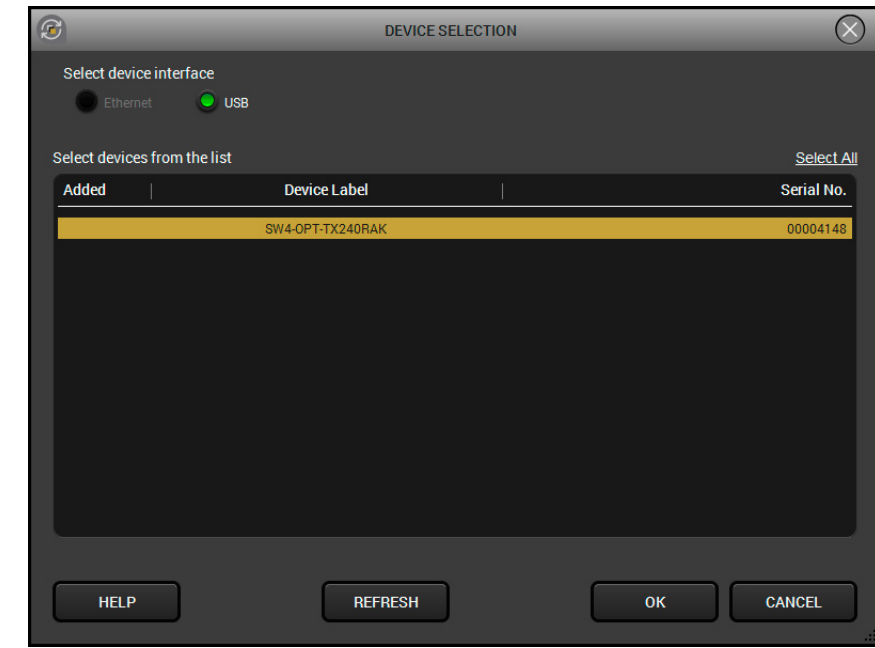
**Step 2.** Select a device.

The next step is to select the desired device(s). The available and supported devices are searched for and listed automatically. If the desired device is not listed, update the list by clicking the **Refresh** button. Select the desired device by highlighting them: highlight them with a **yellow cursor**, then click **OK**.

A tick mark can be seen in the **Added** column if the device was added by the user previously.

### Firmware Components

The components of the installed and update firmware version for the selected devices are listed on the following screen. (Update version will be uploaded to the device.)

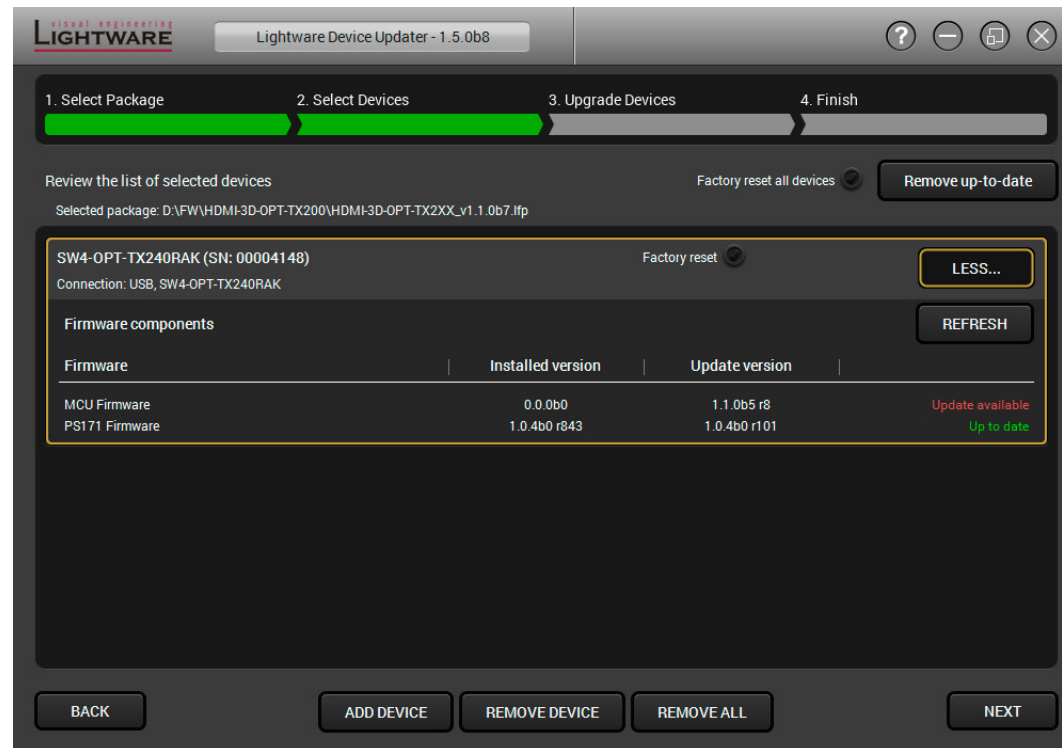

Add a device by clicking on the **Add device** button. The previous screen will be shown; select the desired device(s) and click **OK**.

Remove a device by selecting it (highlight with yellow) and clicking on the **Remove device** button, or by clicking on **Remove all** button to clear the list.

Enabling **Factory reset** will perform factory default values for all settings in the device. Three different status can exist:

- **Enabled by user:** all settings will set to factory default values.
- **Disabled by user:** your settings will be saved and restored after upgrading.
- **Enabled by default and not changeable by user:** firmware upgrade must perform a factory reset to apply all changes coming with the new firmware version.

Click on the **Next** button to continue.

### Step 3. Upgrade the device.

Click on the **Start** button to start the upgrade process.

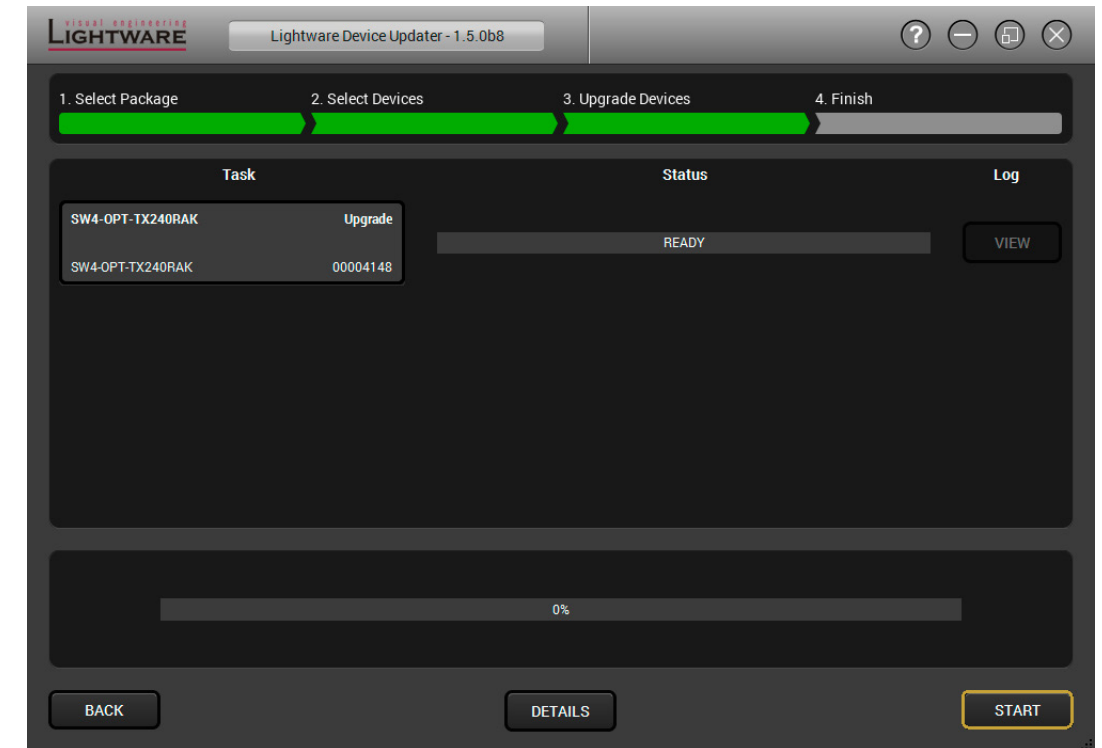

Two warning windows will pop up before upgrading the device:

- Do not power off the device or unplug the USB cable while the upgrade is in progress. Click **OK** to continue.
- The device presets will be lost after the upgrade.

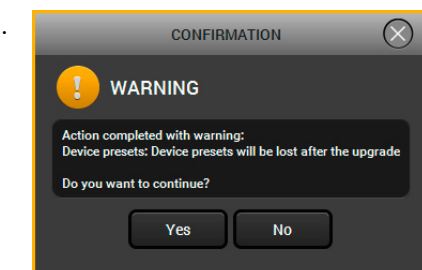
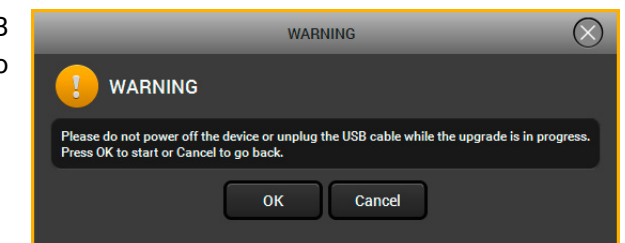



After you confirmed the warnings and clicked on the **Start** button, the upgrade process starts immediately.

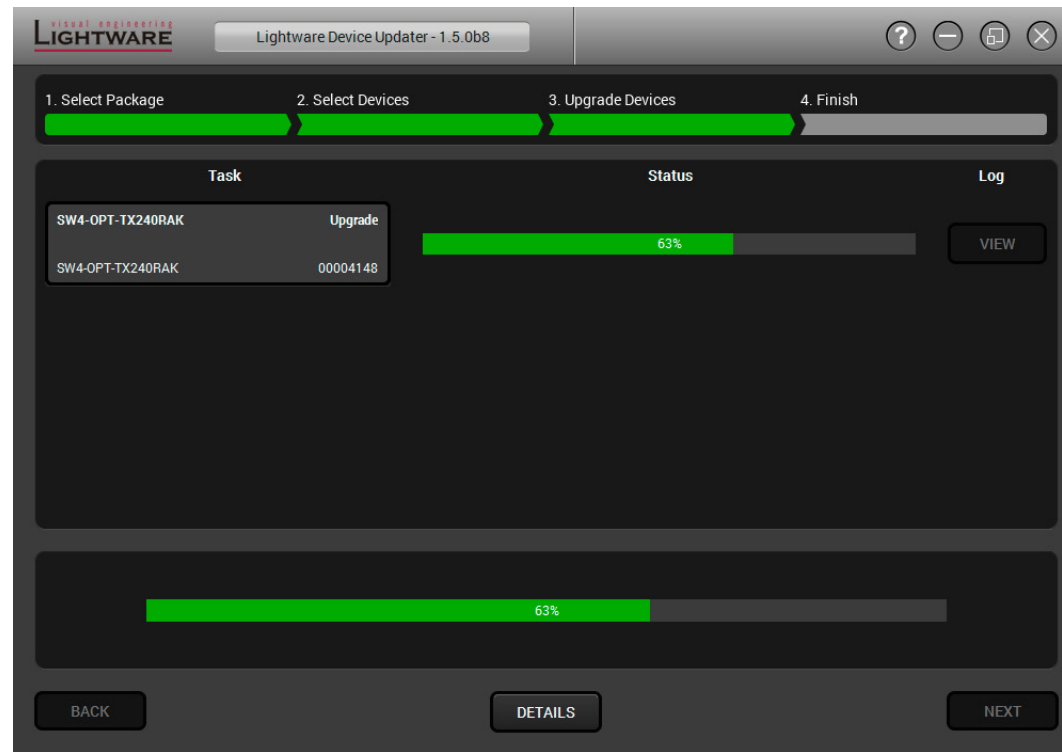

**Details** button opens a new window where the process is logged – see below.

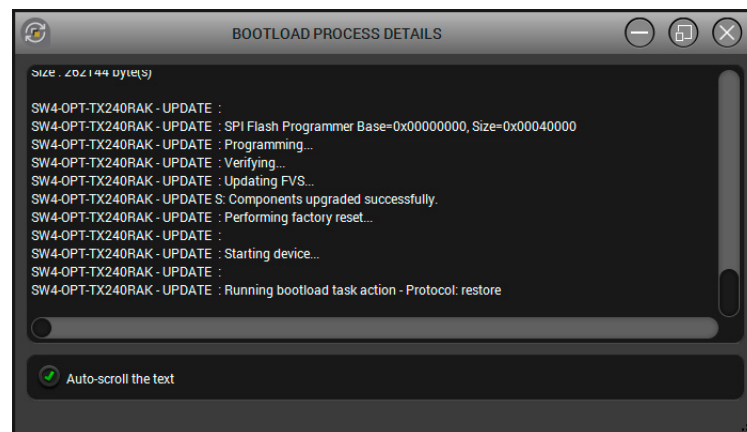

**Step 4. Finish.**

If the upgrade of a device is finished, the log can be opened by the **View** button on the right. When all the tasks are finished, a window appears. Click **OK** to close and **Next** to display the summary page.

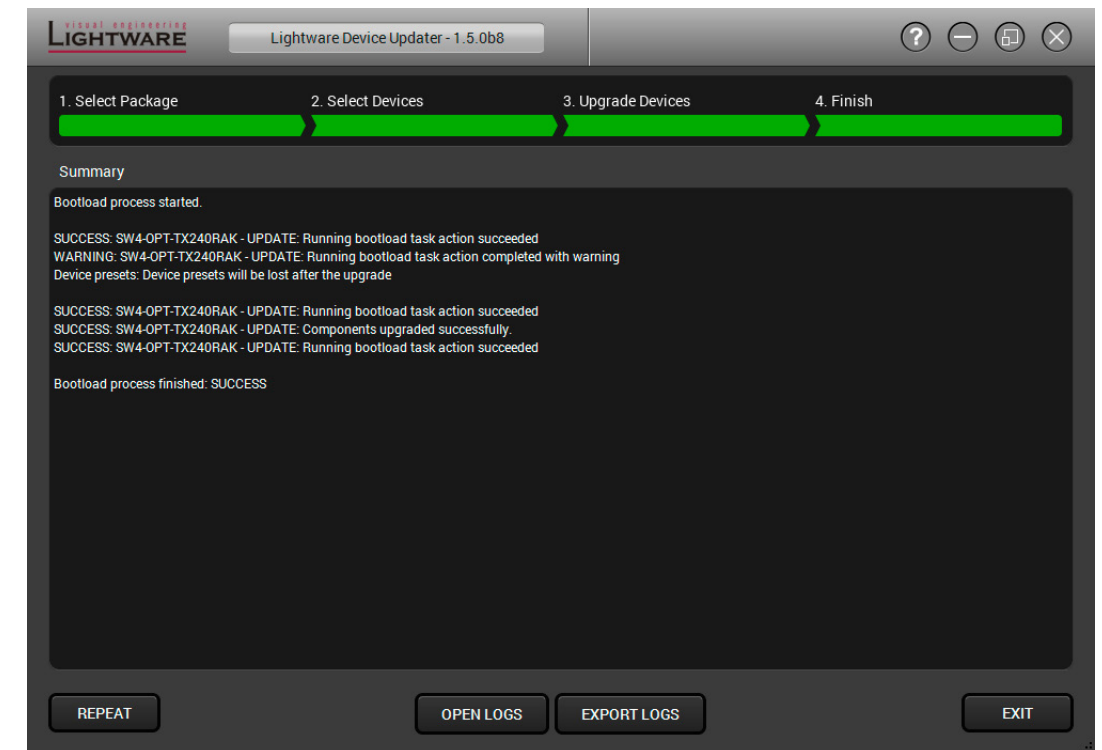

Clicking on the **Repeat** button starts the process again with the selected device(s).

The **Open logs** button opens the temporary folder where the logs can be found.

**Export logs** by saving the files as a zipped file.

Press **Exit** to close the program.

If the upgrade fails, the progress bar of the device turns to red. Restart the device(s) and repeat the process.

**ATTENTION!** Although the device is rebooted after the firmware upgrade, switching it off and on again is recommended.

## 8.5. Keeping the Configuration Settings

User can keep all configuration settings and restore to the device after firmware upgrading or can choose to perform a factory reset – it means all settings will be erased in the device. For the detailed information about saved data refer to [Content of Backup File](#) section.

The following flow chart demonstrates how this function works in the background.



**The flow chart of the firmware upgrade procedure**

The details about the procedure: when firmware upgrade starts, the first step is making a backup of the settings of the device. The firmware package checks the backup data and if it is needed, a conversion is applied to avoid incompatibility problems between the firmware versions. If you do not want to keep configuration settings, you can set the **Factory reset** option enabled.

The instruction in the firmware package of the device will inform you about this function availability, reading it is highly recommended in every case.

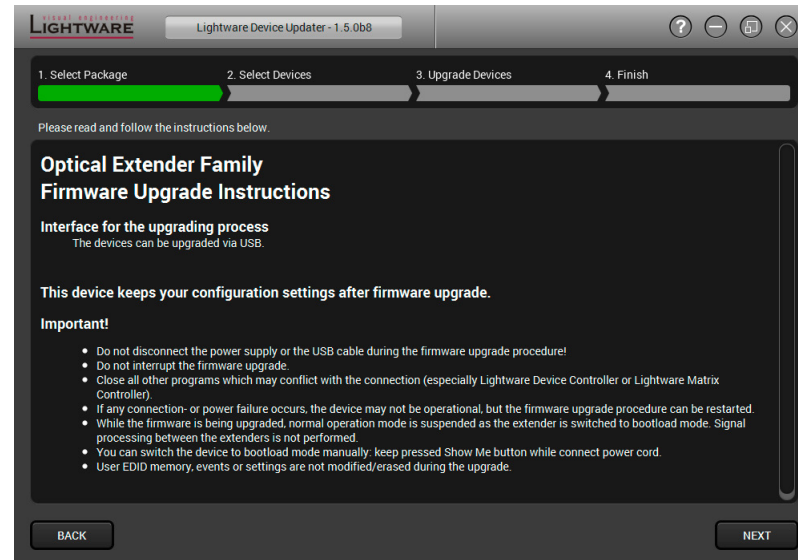

**Instructions page in the optical extender firmware package**

**ATTENTION!** In specific cases restoring cannot be applied fully and certain settings are not copied back to the device. If a warning message appears, user can get back the original data from the backup. Logs of the upgrade procedure contain all backup data, it can be exported at the end of the upgrade procedure. In case of any question, please contact [support@lightware.com](mailto:support@lightware.com).





**ATTENTION!** In certain cases, the new firmware version requires setting all parameters to set factory defaults. In this case, the “Factory reset” option is enabled by default and not changeable by the user, see details in the [Firmware Components](#) section.

**ATTENTION!** The feature is only supported by LDU version 1.3.0 and above.

# 9

















## Troubleshooting























Usually, if the system seems not to transport the signal as expected, the best strategy for troubleshooting is to check signal integrity through the whole signal chain starting from source side and moving forward to the receiver end.

















-  Link to connections/cabling section.
-  Link to front panel operation section.
-  Link to LDC software section.
-  Link to LW2 protocol commands section.
-  Link to LW3 protocol commands section.

### 9.1. Use Case Studies

At first, check front panel LEDs and take the necessary steps according to their states. For more information about status, LEDs refer to [Rear Panel Status LEDs - Transmitter](#) and [Front Panel LEDs - Receiver](#) sections.

Symptom	Root cause	Action	Refer to
<b>Video signal</b>			
<b>No picture on the video output</b>	Device or devices are not powered properly	Check the extenders and the other devices if they are properly powered; try to unplug and reconnect them.	 <a href="#">3.4</a>
	Cable connection problem	Cables must fit very well, check all the connectors (video and optical cables).	 <a href="#">3.4</a>
	Optical cable became contaminated	Use special fiber optical cable cleaning equipment to clean it carefully.	
	No incoming signal (transmitter)	No video signal is present on the HDMI/DVI-D/DP input ports. Check the source device and the HDMI/DVI/DP cable(s).	 <a href="#">3.4</a>
	No incoming signal (receiver)	If the Signal LED does not light, no signal is present on the optical input port. Check the source device and the fiber cable.	 <a href="#">3.4</a>
	The input port is muted	Check the mute state of input port.	 <a href="#">5.4.1</a>  <a href="#">7.6.1</a>
	The output port is muted	Check the mute state of output port.	 <a href="#">5.4.4</a>  <a href="#">6.3.6</a>  <a href="#">7.6.2</a>
	Display is not able to receive the video format	Check the emulated EDID; select another (e.g. emulate the display's EDID on the input port).	 <a href="#">5.7</a>  <a href="#">7.12</a>
HDCP is disabled	Enable HDCP on the input and output ports.	 <a href="#">5.4.1</a>  <a href="#">5.4.4</a>  <a href="#">7.6.17</a>  <a href="#">7.6.18</a>	
<b>Not the desired picture displayed on the video output</b>	Video output is set to test pattern (no sync screen) statically	Check test pattern settings in the properties of the output ports.	 <a href="#">5.5.2</a>  <a href="#">7.6.19</a>
	Video output is set to test pattern (no sync screen) as there is no picture on video source	Check video settings of the source.	

Symptom	Root cause	Action	Refer to
<b>Audio signal</b>			
<b>No audio is present on output</b>	Source audio volume is low or muted	Check the audio settings of the source.	
	Audio input port is muted	Check the audio input port properties	 5.4.2  5.4.3  7.7.1
	Audio output port is muted	Check the output port properties.	 5.4.5  6.3.6  7.7.2
	Analog audio input: volume is set very low (TX)	Check the Analog audio input port settings (Volume).	 5.4.3  7.7.17  7.7.18
	Analog audio output: volume is set very low (RX)	Check the Analog audio output port settings (Volume).	 5.4.6  7.7.19  7.7.20
<b>HDMI output signal contains no audio</b>	HDMI mode was set to DVI	Check the properties of the output port and set the signal type to HDMI or Auto.	 5.4.4  7.6.20
	DVI EDID is emulated	Check the EDID and select and HDMI EDID to emulate.	 5.7  7.12
<b>RS-232 signal</b>			
<b>Connected serial device does not respond</b>	Cable connection problem	Check the connectors to fit well; check the wiring of the plugs.	 3.4.9  3.4.10
	RS-232 settings are different	Check the port settings of the extender and the connected serial device(s).	 5.8.1  7.9
	RS-232 mode is not right	Check the RS-232 mode settings (control, pass-through, or command injection)	 5.8.1  7.9.6

Symptom	Root cause	Action	Refer to
<b>Ethernet (only for SW4-OPT-TX240RAK)</b>			
<b>No LAN connection can be established</b>	Incorrect IP address is set (fix IP)	Use dynamic IP address by enabling DHCP option.	 4.3.1  5.10.2  7.8.2
		Restore the factory default settings (with fix IP).	 4.3.2  5.10.4  6.2.11  7.5.6
	IP address conflict	Check the IP address of the other devices, too.	
<b>USB KVM</b>			
<b>USB device does not operate</b>	Cables are not connected on both sides	Check the USB cable between TX and the computer.	
	Not supported USB device is connected	Keyboard, mouse (USB HID devices) are supported mostly, check your device type	
	USB crosspoint set to the non-active channel	Check the USB mode in the transmitter in LDC and change to the active channel.	 5.6.2
	Incorrect USB mode is set	Check the USB mode in the receiver in LDC and change to Composite or Transparent mode.	 5.6.1
<b>GPIO</b>			
<b>Connected device does not respond</b>	Cable connection problem	Check the connectors to fit well; check the wiring of the plugs.	 3.4.14
<b>Output level cannot be changed</b>	The direction of the selected pin is set to input	Check and modify the direction setting of the desired pin	 5.8.2  6.5.1  7.11
<b>Miscellaneous</b>			
<b>Front panel buttons are out of operation</b>	Buttons are locked	Unlock the buttons	 4.3.3
<b>Error messages received continuously</b>	Different protocol is set	Check the port protocol settings (LW2 / LW3) and use the proper protocol commands.	 5.8.1  7.9.1

## 9.2. How to Speed Up the Troubleshooting Process

Lightware's technical support team is always working hard to provide the fastest support possible. Our team's response time is one of the best in the industry and in the toughest of cases we can directly consult with the hardware or software engineer who designed the product to get the information from the most reliable source.

However, the troubleshooting process can be even faster... with your help.

There are certain pieces of information that push us in the right direction to finding the root cause of the problem. If we receive most of this information in the first e-mail or it is gathered at the time when you call us, then there is a pretty high chance that we will be able to respond with the final solution right away.

### This information is the following:

- Schematic (a pdf version is preferred, but a hand drawing is sufficient).
- Serial number(s) of the device(s) (it is either printed somewhere on the box or you can query it in the Device Controller software or on the built-in website).
- Firmware versions of the devices (please note that there may be multiple CPUs or controllers in the device and we need to know all of their firmware versions, a screenshot is the best option).
- Cable lengths and types (in our experience, it's usually the cable).
- Patch panels, gender changers or anything else in the signal path that can affect the transmission.
- Signal type (resolution, refresh rate, color space, deep color).
- Emulated EDID(s) (please save them as file and send them to us).
- Actions to take in order to re-create the problem (if we cannot reproduce the problem, it is hard for us to find the cause).
- Photo or video about the problem ('image noise' can mean many different things, it's better if we see it too).
- Error logs from the Device Controller software.
- In the case of Event Manager issue the event file and/or backup file from the Device Controller software.

The more of the above information you can give us the better. Please send these information to the Lightware Support Team ([support@lightware.com](mailto:support@lightware.com)) to speed up the troubleshooting process.

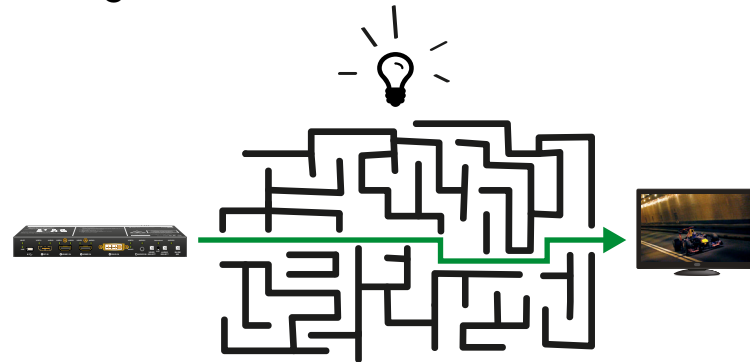

# 10

## Technologies

The following sections contain descriptions and useful technical information how the devices work in the background. The content is based on experiences and cases we met in the practice. These sections help to understand features and technical standards like the followings:

- ▶ EDID MANAGEMENT
- ▶ HDCP MANAGEMENT
- ▶ PIXEL ACCURATE RECLOCKING

### 10.1. EDID Management

#### 10.1.1. Understanding the EDID

The Extended Display Identification Data (EDID) is the passport of display devices (monitors, TV sets, projectors). It contains information about the capabilities of the display, such as supported resolutions, refresh rates (these are called Detailed Timings), the type and manufacturer of the display device, etc.

After connecting a source to a display (DVI, HDMI, DP), the source reads out the EDID to determine the resolution and refresh rate of the image to be transmitted.

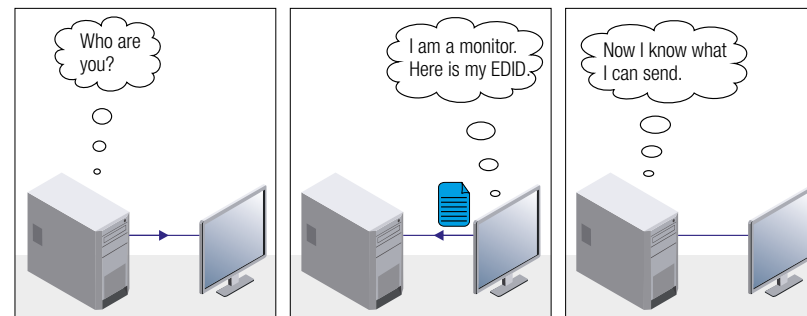

**EDID Communication**

Most DVI computer displays have 128-byte long EDID structure. However, Digital Televisions and HDMI capable displays may have another 128 bytes, which is called E-EDID and defined by CEA (Consumer Electronics Association). This extension contains information about additional Detailed Timings, audio capabilities, speaker allocation and HDMI capabilities. It is important to know that all HDMI capable devices must have CEA extension, but not all devices with CEA extension are HDMI capable.

#### Common Problems Related to EDID

**Problem:** "My system consists of the following: a computer, a Lightware device, a WUXGA (1920x1200) LCD monitor, and an SXGA (1280x1024) projector. I would like to see the same image on the monitor and the projector. What EDID should I choose on the Lightware device?"

**Solution:** If you want to see the image on both displays, you need to select the resolution of the smaller display (in this case SXGA), otherwise the smaller display may not show the higher resolution image.

**Problem:** "I have changed to a different EDID on an input port of the Lightware device to have a different resolution but nothing happens."

**Solution:** Some graphics cards and video sources read out the EDID only after power-up and later they do not sense that EDID has been changed. You need to restart your source to make it read out the EDID again.

#### 10.1.2. Advanced EDID Management

Each DVI sink (e.g. monitors, projectors, plasma displays, etc...) must support the EDID data structure. Source BIOS and operating systems are likely to query the sink using DDC2B protocol to determine what pixel formats and interface are supported. DVI standard uses EDID data structure to identify the monitor type and capabilities. Most DVI sources (VGA cards, set top boxes, etc.) will output DVI signal after accepting the connected sink's EDID information. In the case of EDID readout failure or missing EDID, the source will not output DVI video signal.

Lightware devices provide the Advanced EDID Management function that helps system integration. The built-in EDID Router can store and emulate factory pre-programmed- and User programmable EDIDs. The EDID of the attached monitors or projectors for each output are stored in a non-volatile memory. This way the EDID of a monitor is available when the monitor is unplugged or switched off.

Any EDID can be emulated on any input. An emulated EDID can be copied from the EDID router's memory (static EDID emulation), or from the last attached monitor's memory (dynamic EDID emulation). For example, the Lightware device can be set up to emulate a sink device, which is connected to one of the outputs. In this case, the EDID automatically changes, if the monitor is replaced with another display device (as long as it has a valid EDID).

EDID is independently programmable for all inputs without affecting each other. All inputs have their own EDID circuit.

**INFO:** The user is not required to disconnect the video cable to change an EDID as opposed to other manufacturer's products. EDID can be changed even if a source is connected to the input and powered ON.

**INFO:** When EDID has been changed, the router toggles the HOTPLUG signal for 2 seconds. Some sources do not sense this signal. In such cases, the source device must be restarted or powered OFF and ON again.

## 10.2. HDCP Management

Lightware Visual Engineering is a legal HDCP adopter. Several functions have been developed which helps to solve HDCP related problems. Complex AV systems often have both HDCP and non-HDCP components. The transmitter allows transmitting HDCP encrypted and unencrypted signals. The devices will be still HDCP compliant as they will never output an encrypted signal to a non-HDCP compliant display device. If an encrypted signal is switched to a non-compliant output, a red screen alert or muted screen will appear.

### 10.2.1. Protected and Unprotected Content

Many video sources send HDCP protected signal if they detect that the sink is HDCP capable – even if the content is not copyrighted. This can cause trouble if an HDCP capable device is connected between the source and the display. In this case, the content cannot be viewed on non-HDCP capable displays and interfaces like event controllers. Rental and staging technicians often complain about certain laptops, which are always sending HDCP encrypted signals if the receiver device (display, matrix router, etc.) reports HDCP compliancy. However, HDCP encryption is not required all the time e.g. computer desktop image, certain laptops still do that.

To avoid unnecessary HDCP encryption, Lightware introduced the HDCP enabling/disabling function: the HDCP capability can be disabled in the Lightware device. If HDCP is disabled, the connected source will detect that the sink is not HDCP capable, and turn off authentication.

### 10.2.2. Disable Unnecessary Encryption

#### HDCP Compliant Sink

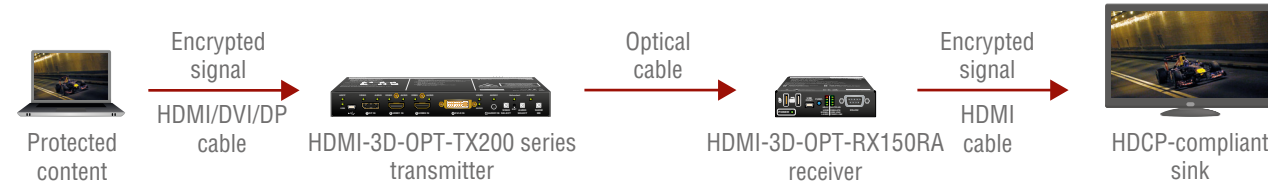

All the devices are HDCP-compliant, no manual setting is required, both protected and unprotected contents are transmitted and displayed on the sink.

#### Not HDCP-compliant Sink 1.

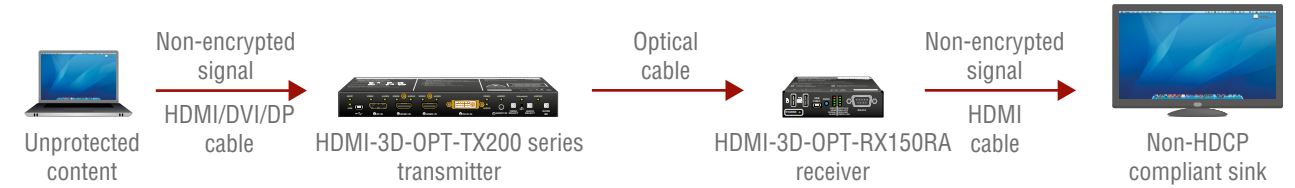

Not-HDCP compliant sink is connected to the receiver. Some sources (e.g. computers) always send HDCP encrypted signals if the receiver device reports HDCP compliancy, however, HDCP encryption is not required all the time (e.g. computer desktop image). If HDCP is enabled in the transmitter, the image will not be displayed on the sink.

Setting the HDCP parameter to Auto on the output port and disable HDCP on the input port, the transmitted signal will not be encrypted if the content is not protected. Thus, non-HDCP compliant sinks will display non-encrypted signal.

#### Not HDCP-compliant Sink 2.

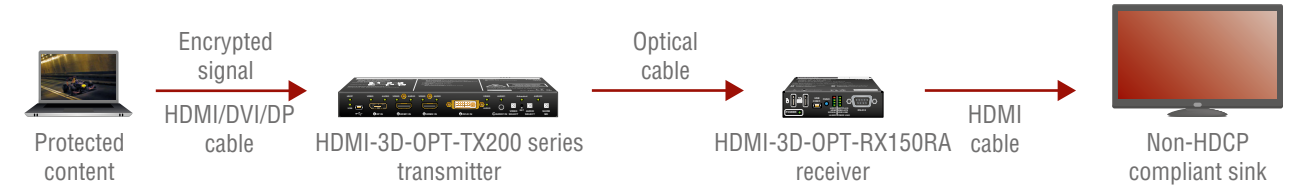

The layout is the same as in the previous case: non-HDCP compliant display device is connected to the receiver but the source would send protected content with encryption. If HDCP is enabled on the input port of the transmitter, the source will send encrypted signal. The sink is not HDCP compliant, thus, it will not display the video signal (but blank/red/muted/etc. screen). If HDCP is disabled on the input port of the transmitter, the source will not send the signal. The solution is to replace the display device to an HDCP-capable one.

### 10.3. Pixel Accurate Reclocking

Signal reclocking is an essential important procedure in digital signal transmission. After passing the reclocking circuit, the signal becomes stable, jitter-free, and can be transmitted over more equipment like processors, or event controllers. Without reclocking, sparkles, noise, and jaggies appear on the image.

Lightware's sophisticated Pixel Accurate Reclocking technology fixes more problems than general TMDS reclocking. It removes not only intra-pair skew but inter-pair skew as well. The Pixel Accurate Reclocking circuit eliminates the following errors:

#### Intra-pair skew

Skew between the + and - wires within a differential wire pair (e.g. Data2- and Data2+). It's caused by different wire lengths or slightly different wire construction (impedance mismatch) in DVI cable. It results in jitter.

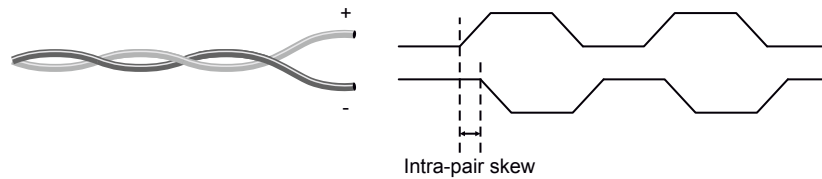

#### Inter-pair skew

Skew between two differential wire pairs in a cable. It is caused by different wire pair lengths or different number of twists in the DVI cable. Too much inter-pair skew results color shift in the picture or sync loss.

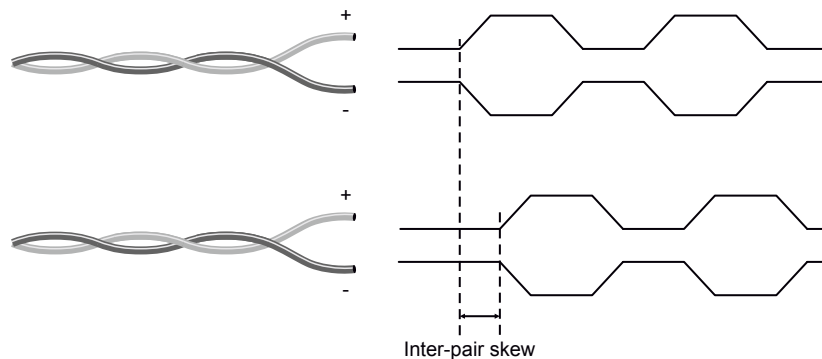

#### Jitter

Signal instability in the time domain. The time difference between two signal transitions should be a fixed value, but noise and other effects cause variations.

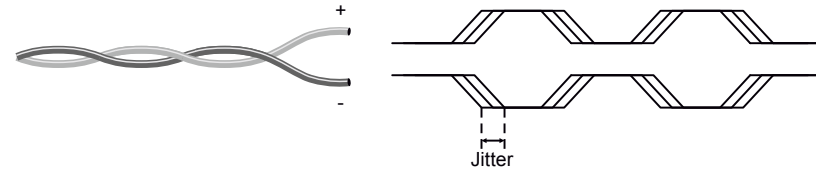

#### Noise

Electromagnetic interference between other electronic devices such as mobile phones, motors, etc. and the DVI cable are coupled onto the signal. Too much noise results in increased jitter.

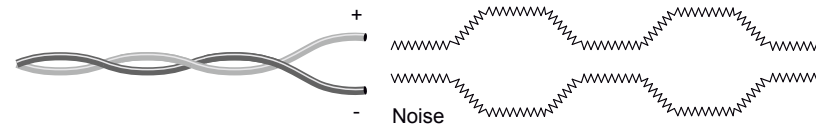



# 11

## Appendix

Tables, drawings, guides, and technical details as follows:

- ▶ [SPECIFICATION](#)
- ▶ [INPUT/OUTPUT PORT NUMBERING](#)
- ▶ [FACTORY DEFAULT SETTINGS](#)
- ▶ [CONTENT OF BACKUP FILE](#)
- ▶ [MAXIMUM FIBER CABLE EXTENSIONS](#)
- ▶ [MECHANICAL DRAWINGS](#)
- ▶ [AUDIO CABLE WIRING GUIDE](#)
- ▶ [FACTORY EDID LIST](#)
- ▶ [FURTHER INFORMATION](#)

### 11.1. Specification

#### 11.1.1. HDMI-3D-OPT-TX200 series Transmitters

##### General

Compliance .....	CE
EMC compliance - emission.....	EN 55032:2015
EMC compliance - immunity .....	EN 55024:2011
Warranty .....	3 years
Cooling.....	Passive
Operating temperature .....	0 to +55°C (+32 to +122°F)
Operating humidity .....	10% to 90%, non-condensing

##### Power

Power supply.....	External power adaptor
Power adaptor.....	In 100-240 V AC 50/60 Hz, Out 5V DC, 1 A
Power connector.....	Locking DC connector (2.35 mm pin)
Power consumption (HDMI-3D-OPT-TX210A) .....	2,5 W (typ)
Power consumption (HDMI-3D-OPT-TX210RAK).....	3 W (typ)
Power consumption (SW4-OPT-TX240RAK) .....	6 W (typ)

##### Enclosure

Rack mountable .....	Yes
Material.....	1 mm steel
Dimensions in mm.....	221W x 100.4D x 26H
Dimensions in inch .....	8.7 W x 3.95 D x 1.02 H
Weight (HDMI-3D-OPT-TX210A) .....	605 g
Weight (HDMI-3D-OPT-TX210RAK).....	605 g
Weight (SW4-OPT-TX240RAK) .....	627 g

##### EDID Management

EDID emulation .....	Yes
EDID memory .....	84 factory presets, 14 user programmable

##### Video Inputs

###### DisplayPort input

DisplayPort connector type.....	20-pole, DP 1.1a receptacle
Color depth.....	Deep color support up to 36 bits, 12 bit/color
Color space .....	RGB, YCbCr 4:4:4, YCbCr 4:2:2, YCbCr 4:2:0
Video delay.....	0 frame
Max. resolutions .....	2560x1600@60 Hz
.....	1920x1080@120 Hz, 8 bit/color
.....	4096x2160@30 Hz
3D support.....	Yes
HDCP 1.4 compliant .....	Yes

###### HDMI input

HDMI connector type.....	19-pole HDMI Type A receptacle
Standard .....	DVI 1.0, HDMI 1.4
Color depth.....	Deep color support up to 36 bits, 12 bit/color
Color space .....	RGB, YCbCr 4:4:4, YCbCr 4:2:2, YCbCr 4:2:0
Video delay.....	0 frame
Max. resolutions .....	1600x1200@60 Hz, 36 bit
.....	1920x1080@120 Hz
.....	3840x2160@30 Hz, 24 bit
Reclocking.....	Pixel Accurate Reclocking
HDCP 1.4 compliant .....	Yes

###### DVI-I input with DVI-D support

Connector type.....	29-pole, DVI-I
Standard .....	DVI 1.0, HDMI 1.4
Color depth.....	Deep color support up to 36 bits, 12 bit/color
Color space .....	RGB, YCbCr 4:4:4, YCbCr 4:2:2, YCbCr 4:2:0
Video delay.....	0 frame
Max. resolutions .....	1600x1200@60 Hz, 36 bit
.....	1920x1080@120 Hz
.....	3840x2160@60 Hz, 24 bit
Reclocking.....	Pixel Accurate Reclocking

3D support.....	Yes
HDCP 1.4 compliant .....	Yes

**Audio Inputs****Embedded audio signal**

Supported on.....	DP, DVI-D, HDMI ports
Supported audio formats .....	PCM (up to 192 kHz), MPCM (up to 8 channels)

**Analog audio input**

Signal type.....	PCM, Compressed, DSD, High Bitrate
Sampling frequency.....	48 kHz
Volume.....	-78 dB – 0 dB
Balance.....	0 - 100 (50 = center)
Gain.....	0 dB – 6 dB
Connector .....	3.5 mm Jack, 5-pole Phoenix connector

**RS-232 Control**

Serial port connector .....	3-pole Phoenix connector
Available Baud rates .....	between 4800 and 115200

**GPIO**

Port connector .....	8-pole Phoenix connector
Port direction.....	Input or output

**USB**

USB connector .....	USB mini B type
USB 2.0 compliance.....	Yes

**Optical**

Fiber type.....	50/125 SC Multimode (preferred), 62.5/125 SC Multimode
Laser wavelengths.....	High speed lanes: 778; 800; 825; 850 nm ..... Low speed lane: 911; 980 nm
Laser class specification.....	Class 3R

**11.1.2. HDMI-3D-OPT-RX150RA Receiver****General**

Compliance .....	CE
EMC compliance (emission/ immunity).....	EN 55032:2015 / EN 55024:2011
Warranty .....	3 years
Cooling.....	Passive
Operating temperature .....	0 to +55°C (+32 to +122°F)
Operating humidity .....	10% to 90%, non-condensing

**Power**

Power supply.....	External power adaptor
Power adaptor.....	In 100-240 V AC 50/60 Hz, Out 5V DC, 1 A
Power connector.....	Locking DC connector (2.35 mm pin)
Power consumption.....	3,9 W (typ); 6,5 W (max)

**Enclosure**

Rack mountable .....	Yes
Material.....	1 mm steel
Dimensions in mm.....	100.4W x 131.9D x 26H
Dimensions in inch .....	8.7 W x 3.95 D x 1.02 H
Weight.....	430 g

**HDMI Output**

HDMI connector type.....	19-pole HDMI Type A receptacle
Standard .....	DVI 1.0, HDMI 1.4
Color depth.....	Deep color support up to 36 bits, 12 bit/color
Color space .....	RGB, YCbCr 4:4:4, YCbCr 4:2:2, YCbCr 4:2:0
Video delay.....	0 frame
Max. resolutions .....	1600x1200@60 Hz, 36 bit ..... 1920x1080@120 Hz, 24 bit ..... 3840x2160@30 Hz, 24 bit
HDCP 1.4 compliant .....	Yes

**Audio Outputs****Embedded audio signal**

Supported on.....	DP, DVI-D, HDMI ports
Supported audio formats .....	PCM (up to 192 kHz) ..... MPCM (up to 8 channels)

**Analog audio output**

Connector type.....	5-pole Phoenix connector
Signal type.....	PCM, Compressed, DSD, High Bitrate
Sampling frequency.....	48 kHz
Volume.....	-78 dB – 0 dB
Balance.....	-100 - 100 (0 = center)

**S/PDIF output**

Audio format .....	S/PDIF
Supported sample rates .....	16 to 48 kHz
AES/EBU compatibility .....	No
Bit depths .....	Up to 24 bits

**Optical**

Fiber type.....	50/125 SC Multimode (preferred), 62.5/125 SC Multimode
Laser wavelengths.....	High speed lanes: 778; 800; 825; 850 nm ..... Low speed lane: 911; 980 nm
Laser class specification.....	Class 3R

**RS-232 Control**

Serial port connector .....	9-pole D-sub
Available Baud rates .....	between 4800 and 115200
Signal type.....	RX/TX bidirectional

**USB for KVM**

Connector type.....	2 x USB-A female
USB 2.0 compliance.....	Yes

**USB Control**

USB connector .....	USB mini B type
USB 2.0 compliance.....	Yes

## 11.2. Input/Output Port Numbering

The following tables contain the input and output ports with their ID numbers which shall be used when protocol command sending or in Lightware Device Controller.

### HDMI-3D-OPT-TX210A

#### Audio/Video Ports

Port name	Video port nr. (LW2 / LW3)	Emulated EDID memory	Audio port nr. (LW2 / LW3)
HDMI in	I1	E1	I1
Audio1 in	-	-	I2
Audio2 in	-	-	I3
Optical link out	O1	-	O1
Local HDMI out	O2	-	O2

### HDMI-3D-OPT-TX210RAK

#### Audio/Video Ports

Port name	Video port nr. (LW2 / LW3)	Emulated EDID memory	Audio port nr. (LW2 / LW3)
HDMI in	I1	E1	I1
Audio1 in	-	-	I2
Audio2 in	-	-	I3
Optical link out	O1	-	O1
Local HDMI out	O2	-	O2

#### USB Ports

Port name	Port nr. (LW3)
USB connector	D1
USB Composite channel	S1
USB Transparent channel 1	S2
USB Transparent channel 2	S3

#### RS-232 Ports

Port name	Port nr. (LW2 / LW3)
Local serial port	P1
Optical serial link	P2

### SW4-OPT-TX240RAK

#### Audio/Video Ports

Port name	Video port nr. (LW2 / LW3)	Emulated EDID memory	Audio port nr. (LW2 / LW3)
DP in	I1	E1	I1
HDMI1 in	I2	E2	I2
HDMI2 in	I3	E3	I3
DVI-D in	I4	E4	I4
Audio1 in	-	-	I5
Audio2 in	-	-	I6
Optical link out	O1	-	O1
Local HDMI out	O2	-	O2

#### USB Ports

Port name	Port nr. (LW3)
USB connector	D1
USB Composite channel	S1
USB Transparent channel 1	S2
USB Transparent channel 2	S3

#### RS-232 Ports

Port name	Port nr. (LW2 / LW3)
Local serial port	P1
Optical serial link	P2

### HDMI-3D-OPT-RX150RA

#### Audio/Video Ports

Port name	Video port nr. (LW2 / LW3)	Emulated EDID memory	Audio port nr. (LW2 / LW3)
Optical link in	I1	E1	I1
HDMI out	O1	-	O1
S/PDIF audio out	-	-	O2
Analog audio out	-	-	O3

#### USB Ports

Port name	Port nr. (LW3)
USB connector - Mouse	S1
USB connector - Keyboard	S2
USB Composite channel	D1
USB Transparent channel 1	D2
USB Transparent channel 2	D3

#### RS-232 Ports

Port name	Port nr. (LW2 / LW3)
Local serial port	P1
Optical serial link	P2

## 11.3. Factory Default Settings

### 11.3.1. Transmitter

Parameter	Setting/Value
<b>Crosspoint settings *</b>	
Video	I1 (DisplayPort)
Audio	I1 (DisplayPort)
<b>Video input port settings (DP*, HDMI, DVI-D*)</b>	
HDCP	Enabled
<b>Video output port settings (optical link and local HDMI)</b>	
HDCP mode	Enabled
Autoselect *	Disabled
Autoselect mode *	Priority detect
Autoselect video priority *	0=DP, 1=HDMI, 2=HDMI2, 3=DVI-D
Test pattern mode	Off
Test pattern resolution	480p
Test pattern	Bar
Signal type	Auto
HDCP mode	Auto
Laser enable	On
<b>Analog audio input port properties</b>	
Volume	0.00 dB
Balance	0 (center)
Gain	0.00 dB
<b>Audio output port settings (optical link and local HDMI)</b>	
Autoselect *	Disabled
Autoselect mode *	Priority detect
Autoselect video priority *	0=DP, 1=HDMI, 2=HDMI2, 3=DVI-D, 4=Analog 1 (Jack), 5=Analog 2 (Phoenix)
<b>Network settings *</b>	
IP address	192.168.0.100
Subnet mask	255.255.255.0
Static gateway	192.168.0.1
DHCP	Disabled
LW2 / LW3 port number	10001

Parameter	Setting/Value
<b>RS-232 settings</b>	
Control protocol	LW2
Baud rate / Databits / Parity / Stopbits	57600 / 8 / No / 1
Operation mode	Pass-through
Command injection port nr.	8001
<b>GPIO port settings *</b>	
Direction	Input
Output level	High

\* Only for SW4-OPT-TX240RAK model.

### 11.3.2. Receiver

Parameter	Setting/Value
<b>Optical input port properties</b>	
HDCP	Enabled
<b>HDMI output port properties</b>	
Signal type	Auto
HDCP mode	Auto
Power 5V mode	Always on
Test pattern mode	Off
Test pattern resolution	480p
Test pattern	Bar
<b>Analog audio output port properties</b>	
Volume	0.00 dB (100%)
Balance	0 (center)
Bass	0.00 dB
Treble	0.00 dB
Phase invert	Disabled
<b>RS-232 settings</b>	
Control protocol	LW2
Baud rate / Databits / Parity / Stopbits	57600 / 8 / No / 1
Operation mode	Pass-through

For the procedure of reloading factory default values in LDC software see the [System](#) section, or using the function buttons see in the [Reset to Factory Default Settings](#) section for the transmitter and the [Reset to Factory Default Settings](#) section for the receiver.

## 11.4. Content of Backup File

The backup file contains numerous settings and parameters saved from the device. When the file is uploaded to a device, the followings will be overwritten:

<b>HDMI input port(s)</b>
Video port name, Audio port name, HDCP setting
<b>DP input port</b>
Video port name, Audio port name, HDCP setting
<b>DVI-D input port</b>
Video port name, Audio port name, HDCP setting
<b>Analog audio input ports</b>
Volume, Balance, Gain, Port name
<b>Crosspoint settings</b>
Audio autoselect settings, Mute ports, Lock ports, Switch ports
Video autoselect settings, Mute ports, Lock ports, Switch ports
<b>Optical output port</b>
Video port name, Audio port name
Test pattern mode, clock source, and type
HDCP mode, HDMI mode
RS-232 mode, Control protocol, CI port number, Port name
Remote port name, Enabled/Disabled setting
<b>Local output port</b>
Port name, HDCP mode, HDMI mode, Power +5V mode
Test pattern mode, clock source, and type
<b>Serial port</b>
RS-232 mode, Control protocol, Baud rate, Data bits, Stop bits, Parity
Port name and CI (Command Injection) port number
<b>Network settings (only for SW4-OPT-TX240RAK model)</b>
DHCP status (enable / disable)
Static IP address, Network mask, Gateway address
<b>Further settings</b>
GPIO port names, directions (input/output), and levels (high/low)
User EDID data (Transmitter: U1-U14; Receiver: U1-U15)
Event manager: settings of all Events (E1-E20)

For the description of backup/restore procedure see the [Configuration Cloning \(Backup Tab\)](#) section.

## 11.5. Maximum Fiber Cable Extensions

	<b>OM1</b>	<b>OM2</b>	<b>OM3</b>	<b>OM4</b>
	<b>(62.5/125)</b>	<b>(50/125)</b>	<b>(50/125)</b>	<b>(50/125)</b>
1080p@60Hz 24 bpp	250 m	600 m	1200 m	2500 m
1080p@60Hz 36 bpp	150 m	400 m	800 m	1300 m
4096x2048@30Hz 24 bpp	Not supported	350 m	700 m	1100 m

## 11.6. Mechanical Drawings

### 11.6.1. Transmitter

SW4-OPT-TX240RAK can be seen in the pictures but the dimensions are valid for all the models. Dimensions are in mm.

Bottom View

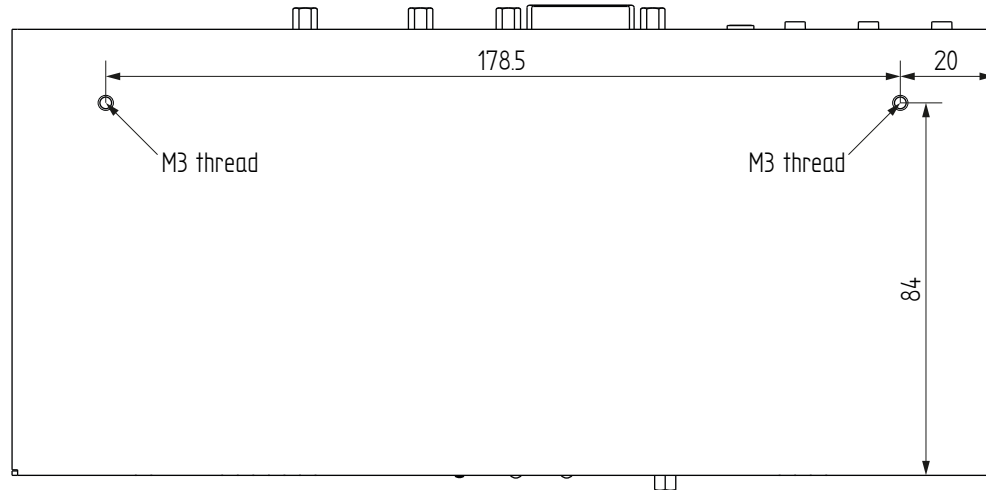

Front View

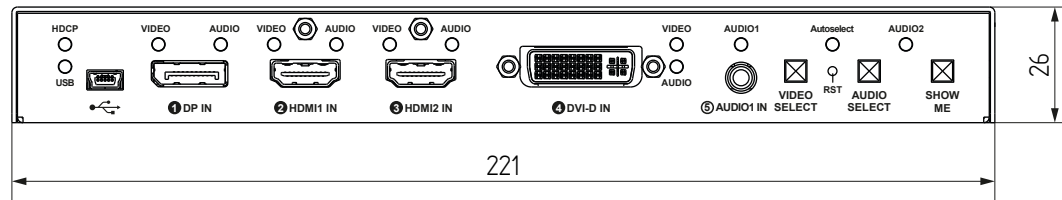

Top View

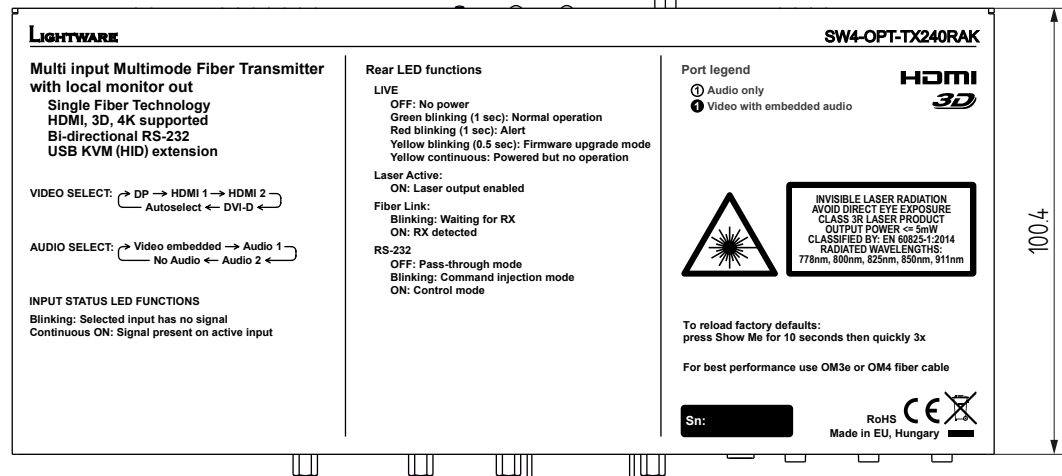

Rear View

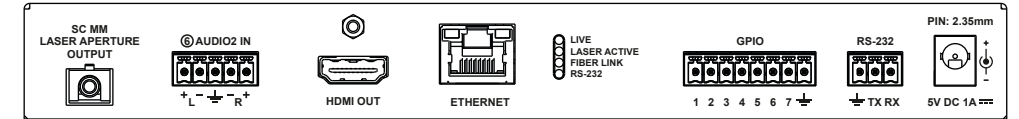

Side View

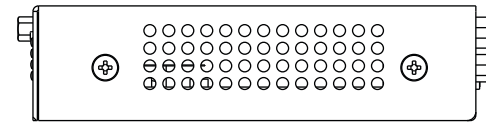

### 11.6.2. Receiver

The following drawings present the physical dimensions of the HDMI-3D-OPT-RX150RA receiver. Dimensions are in mm.

Front View

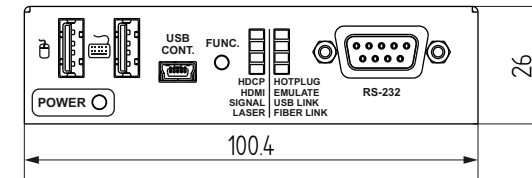

Rear View

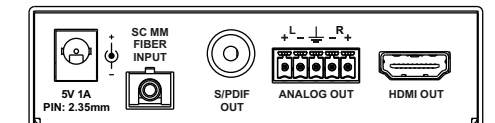

Bottom View

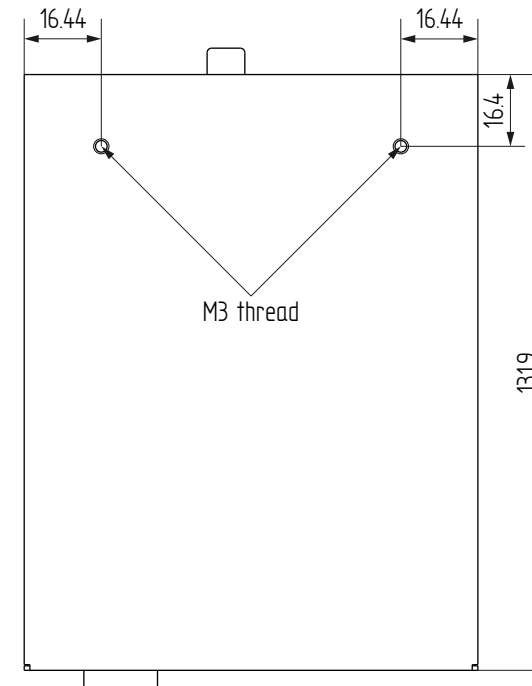

Top View

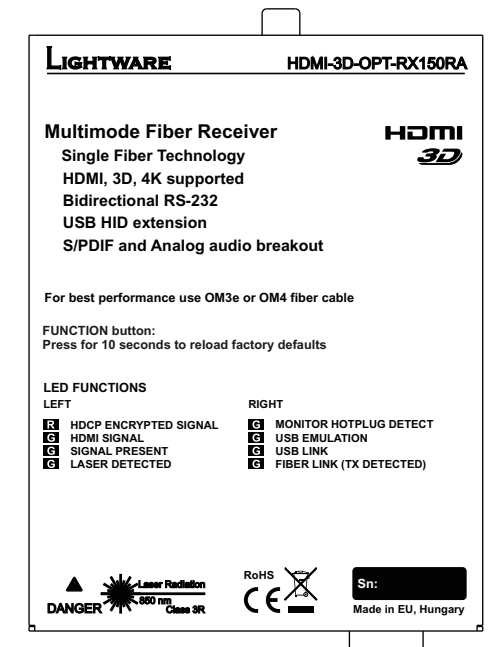

## 11.7. Audio Cable Wiring Guide

Inputs and outputs of audio devices are symmetric or asymmetric. The main advantage of the symmetric lines is the better protection against the noise therefore, they are widely used in the professional audio industry. Symmetric audio is most often referred to as balanced audio, as opposed to asymmetric, which is referred to as unbalanced audio. Lighware products are usually built with 5-pole Phoenix connectors so we would like to help users assembling their own audio cables. See the most common cases below.

**ATTENTION!** Symmetric and asymmetric lines can be linked with passive accessories (e.g. special cables), but in this case half of the line level is lost.

**ATTENTION!** There are numerous types of regularly used connector and cable types to connect audio devices. Please always make sure that a connector or cable fits your system before use.

**ATTENTION!** Never join the phase-inverted (negative, cold or -) poles (either right and left) to the ground or to each other on the output side, as this can damage the unit.

**INFO:** Use a galvanic isolation in case of a ground loop.

### The Pinout of the 5-pole Phoenix Connector

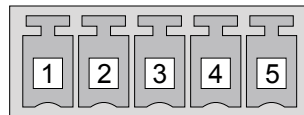

Pin nr.	Signal
1	Left+
2	Left-
3	Ground
4	Right-
5	Right+

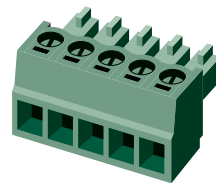

### Compatible Plug Type

Phoenix® Combicon series (3.5mm pitch, 5-pole), type: MC 1.5/5-ST-3.5.

### From Unbalanced Output to Balanced Input

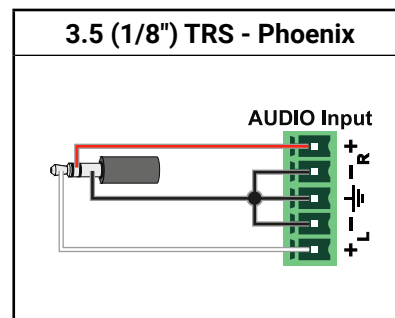
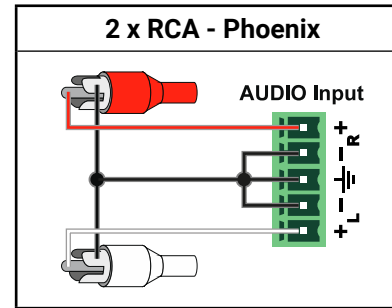
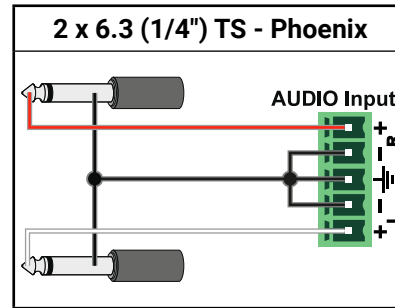

### From Balanced Output to Balanced Input

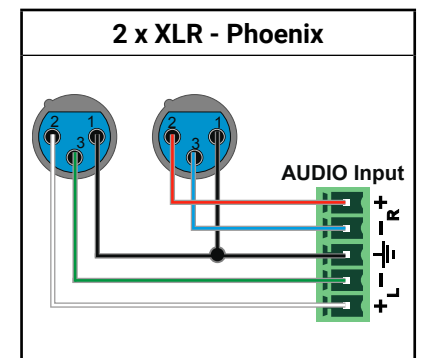
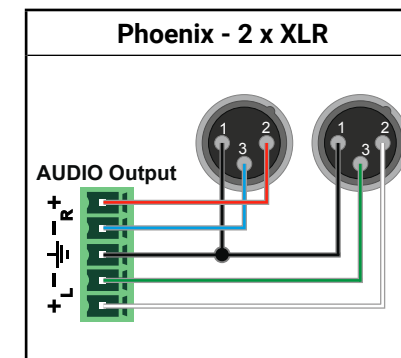
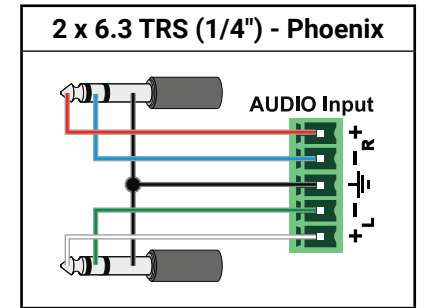
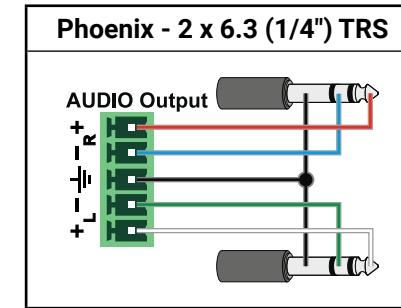

### From Balanced Output to Unbalanced Input

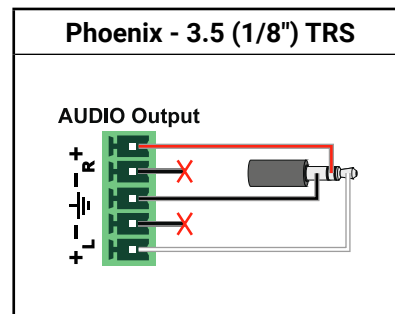
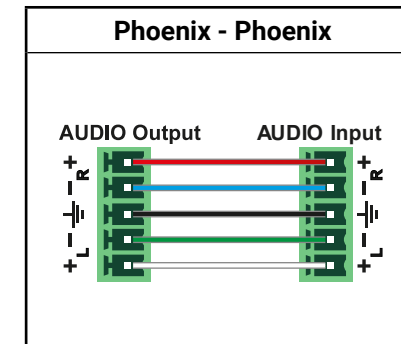
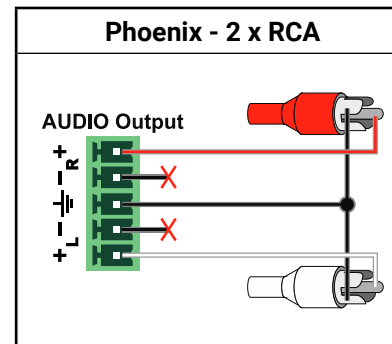
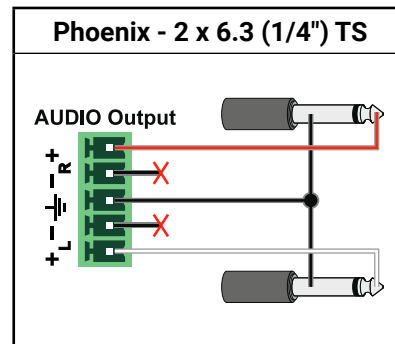

## 11.8. Factory EDID List

Mem.	Resolution				Type	Mem.	Resolution				Type
F1	640 x	480	@ 60.00	Hz	D	F34	720 x	576	@ 50.00	Hz	H
F2	848 x	480	@ 60.00	Hz	D	F35	1280 x	720	@ 50.00	Hz	H
F3	800 x	600	@ 60.32	Hz	D	F36	1280 x	720	@ 60.00	Hz	H
F4	1024 x	768	@ 60.00	Hz	D	F37	1920 x	1080i	@ 50.04	Hz	H
F5	1280 x	768	@ 50.00	Hz	D	F38	1920 x	1080i	@ 50.00	Hz	H
F6	1280 x	768	@ 59.94	Hz	D	F39	1920 x	1080i	@ 60.05	Hz	H
F7	1280 x	768	@ 75.00	Hz	D	F40	1920 x	1080i	@ 60.05	Hz	H
F8	1360 x	768	@ 60.02	Hz	D	F41	1920 x	1080	@ 24.00	Hz	H
F9	1280 x	1024	@ 50.00	Hz	D	F42	1920 x	1080	@ 25.00	Hz	H
F10	1280 x	1024	@ 60.02	Hz	D	F43	1920 x	1080	@ 30.00	Hz	H
F11	1280 x	1024	@ 75.02	Hz	D	F44	1920 x	1080	@ 50.00	Hz	H
F12	1400 x	1050	@ 50.00	Hz	D	F45	1920 x	1080	@ 60.00	Hz	H
F13	1400 x	1050	@ 60.00	Hz	D	F46	1920 x	1080	@ 60.00	Hz	H
F14	1400 x	1050	@ 75.00	Hz	D	F47	Universal_HDMI_PCM			H	
F15	1680 x	1050	@ 60.00	Hz	D	F48	Universal_HDMI_ALL			H	
F16	1920 x	1080	@ 50.00	Hz	D	F49	Universal_HDMI_DC			H	
F17	1920 x	1080	@ 60.00	Hz	D	F50-F89	Reserved				
F18	2048 x	1080	@ 50.00	Hz	D	F90	1920 x	2160	@ 59.99	Hz	D
F19	2048 x	1080	@ 60.00	Hz	D	F91	1024 x	2400	@ 60.01	Hz	D
F20	1600 x	1200	@ 50.00	Hz	D	F92-F93	Reserved				
F21	1600 x	1200	@ 60.00	Hz	D	F94	2048 x	1536	@ 60.00	Hz	D
F22	1920 x	1200	@ 50.00	Hz	D	F95	Reserved				
F23	1920 x	1200	@ 59.56	Hz	D	F96	2560 x	1600	@ 59.86	Hz	D
F24	2048 x	1200	@ 59.96	Hz	D	F97	3840 x	2400	@ 24.00	Hz	D
F25-F28	Reserved				D	F98	1280 x	720	@ 60.00	Hz	H3D
F29	Universal_DVI				D	F99	1920 x	1080	@ 60.00	Hz	H3D
F30	1440 x	480i	@ 60.05	Hz	H	F100	1024 x	768	@ 60.00	Hz	H
F31	1440 x	576i	@ 50.08	Hz	H	F101	1280 x	1024	@ 50.00	Hz	H
F32	640 x	480	@ 59.95	Hz	H	F102	1280 x	1024	@ 60.02	Hz	H
F33	720 x	480	@ 59.94	Hz	H	F103	1280 x	1024	@ 75.02	Hz	H

Mem.	Resolution				Type	Mem.	Resolution				Type
F104	1600 x	1200	@ 50.00	Hz	H	F123	1280 x	800	@ 59.91	Hz	H
F105	1600 x	1200	@ 60.00	Hz	H	F124	1440 x	900	@ 59.90	Hz	H
F106	1920 x	1200	@ 59.56	Hz	H	F125	1368 x	768	@ 59.85	Hz	H
F107	2560 x	1440	@ 59.95	Hz	H	F126	1600 x	900	@ 59.98	Hz	H
F108	2560 x	1600	@ 59.86	Hz	H	F127	2048 x	1080	@ 60.00	Hz	H
F109	3840 x	2400	@ 24.00	Hz	H	F128	2560 x	1080	@ 60.00	Hz	H
F110	3840 x	2160	@ 24.00	Hz	H	F129	3440 x	1440	@ 24.99	Hz	H
F111	3840 x	2160	@ 25.00	Hz	H	F130	3440 x	1440	@ 29.99	Hz	H
F112	3840 x	2160	@ 30.00	Hz	H	F131	4096 x	2160	@ 25.00	Hz	H
F113-F117	Reserved					F132	4096 x	2160	@ 30.00	Hz	H
F118	Universal_4K_PCM				H4K	F133	4096 x	2160	@ 60.00	Hz	H4K
F119	Universal_4K_ALL				H4K	F134	3440 x	1440	@ 23.99	Hz	H
F120	3840 x	2160	@ 60.00	Hz	H4K	F135	4096 x	2160	@ 24.00	Hz	H
F121	1440 x	1080	@ 59.91	Hz	H	F136	3840 x	2400	@ 29.99	Hz	H
F122	2560 x	2048	@ 59.98	Hz	H						

### Legend

Type	Description
D	DVI EDID
H	HDMI EDID
A	Analog EDID
DL	Dual-Link DVI EDID
H3D	HDMI EDID with 3D support
H4K	HDMI EDID with 4K resolution support



## 11.9. Further Information

### Limited Warranty Statement

1. Lightware Visual Engineering LLC (Lightware) warrants to all trade and end user customers that any Lightware product purchased will be free from manufacturing defects in both material and workmanship for three (3) years from purchase unless stated otherwise below. The warranty period will begin on the latest possible date where proof of purchase/delivery can be provided by the customer. In the event that no proof can be provided (empty 'Date of purchase' field or a copy of invoice), the warranty period will begin from the point of delivery from Lightware.

1.1. 25G and MODEX product series will be subject to a seven (7) year warranty period under the same terms as outlined in this document.

1.2. If during the first three (3) months of purchase, the customer is unhappy with any aspect of a Lightware product, Lightware will accept a return for full credit.

1.3. Any product that fails in the first six (6) months of the warranty period will automatically be eligible for replacement and advanced replacement where available. Any replacements provided will be warranted for the remainder of the original unit's warranty period.

1.4. Product failures from six (6) months to the end of the warranty period will either be repaired or replaced at the discretion of Lightware. If Lightware chooses to replace the product then the replacement will be warranted for the remainder of the original unit's warranty period.

2. The above-stated warranty and procedures will not apply to any product that has been:

2.1. Modified, repaired or altered by anyone other than a certified Lightware engineer unless expressly agreed beforehand.

2.2. Used in any application other than that for which it was intended.

2.3. Subjected to any mechanical or electrical abuse or accidental damage.

2.4. Any costs incurred for repair/replacement of goods that fall into the above categories (2.1., 2.2., 2.3.) will be borne by the customer at a pre-agreed figure.

3. All products to be returned to Lightware require a return material authorization number (RMA) prior to shipment and this number must be clearly marked on the box. If an RMA number is not obtained or is not clearly marked on the box, Lightware will refuse the shipment.

3.1. The customer will be responsible for in-bound and Lightware will be responsible for out-bound shipping costs.

3.2. Newly repaired or replaced products will be warranted to the end of the originally purchased products warranty period.

### Document Revision History

Rev.	Release date	Changes	Editor
1.0	31-08-2016	Initial version	Tamas Forgacs
1.1	01-08-2017	Minor updates to firmware v1.1.0 (transmitter) and firmware v2.0.0 (receiver), added USB KVM function, added HDMI-3D-OPTRX150RA receiver to the device list, updated safety information	Tamas Forgacs
2.0	13-10-2017	New document format, updated USB KVM sections, updated LW3 prog. ref. chapter	Tamas Forgacs
2.1	31-10-2018	1080p120Hz signal support info added	Laszlo Zsedenyi

### Contact Us

[sales@lightware.com](mailto:sales@lightware.com)

+36 1 255 3800

[support@lightware.com](mailto:support@lightware.com)

+36 1 255 3810

**Lightware Visual Engineering LLC.**  
Peterdy 15, Budapest H-1071, Hungary

[www.lightware.com](http://www.lightware.com)